

SONY

Digital 4K Video Camera Recorder/Digital HD Video Camera Recorder

FDR-X1000V/HDR-AS200V

How to use

Read This First

Identifying the parts

- [Identifying the parts \[1\]](#)

Screen display

- [Screen display \[2\]](#)

Getting Started

Checking the bundled items

- [Checking the bundled items \[3\]](#)

Inserting the battery pack

- [Inserting the battery pack \[4\]](#)

Charging the battery pack

- [Charging the battery pack \[5\]](#)

Inserting a memory card

- [Inserting a memory card \[6\]](#)
- [The memory cards that can be used with the camera \[7\]](#)

Using the Tripod Adaptor

- [Using the tripod adaptor \(HDR-AS200V only\) \[8\]](#)

Using the Waterproof Case

- [Identifying the parts \(Waterproof case\) \[9\]](#)
- [Using the waterproof case \[10\]](#)
- [On waterproof performance of the waterproof case \[11\]](#)
- [Notes on use for the waterproof case \[12\]](#)
- [Water leakage \[13\]](#)
- [Waterproof packing \[14\]](#)
- [How to check for water leaks \[15\]](#)
- [Maintenance \[16\]](#)

Using Adhesive Mount

- [Using the adhesive mount \[17\]](#)

Shooting

Shooting movies and still images

- [About the REC HOLD \(lock\) switch \[18\]](#)
- [Shooting movies \(Movie mode\) \[19\]](#)
- [Shooting still images \(Photo mode\) \[20\]](#)
- [Loop recording mode \[21\]](#)
- [Interval photo recording mode \[22\]](#)
- [Notes on long-time recording \[23\]](#)

Changing the Settings

List of setting items

- [List of setting items \[24\]](#)
- [How to set the setting items \[25\]](#)

Shooting settings

- [Image quality setting \[26\]](#)

- [SteadyShot \[27\]](#)
- [Flip \[28\]](#)
- [Scene \[29\]](#)
- [White balance \[30\]](#)
- [AE shift \[31\]](#)
- [Color mode \[32\]](#)
- [Movie format \[33\]](#)
- [Audio recording setting \[34\]](#)
- [Wind noise reduction \[35\]](#)
- [Loop recording time \[36\]](#)
- [Still image angle of view \[37\]](#)
- [Still image mode switching \[38\]](#)
- [Still image shooting interval \[39\]](#)
- [Self-timer \[40\]](#)
- [Interval photo recording \[41\]](#)

Camera settings

- [Wi-Fi connection \[42\]](#)
- [GPS log \[43\]](#)
- [Airplane mode \[44\]](#)
- [Mount \[45\]](#)
- [Time Code/User Bit \[46\]](#)
- [IR-Remote Control \[47\]](#)
- [HDMI settings \[48\]](#)
- [USB Power Supply \[49\]](#)
- [Auto power off \[50\]](#)
- [Beep \[51\]](#)
- [Date & time/area setting \[52\]](#)
- [Daylight Saving Time \(Summer time\) setting \[53\]](#)
- [Language setting \[54\]](#)
- [Switching NTSC/PAL \[55\]](#)
- [Version \[56\]](#)
- [Format \[57\]](#)
- [Resetting the settings \[58\]](#)

Viewing

Viewing images on a TV

- [Viewing images on a TV \[59\]](#)

Deleting images

- [Delete \[60\]](#)

Create your movie

Highlight Movie Maker

- [Creating the highlight movie \[61\]](#)
- [Importing the BGM \[62\]](#)
- [Mount \[63\]](#)

Stream real-time movie to a movie streaming site

Live Streaming with your camera (Real time movie streaming)

- [Live Streaming \[64\]](#)
- [Preparing for Live Streaming \[65\]](#)
- [Performing Live Streaming \[66\]](#)
- [Restrictions \[67\]](#)

Using the camera connected to other devices via Wi-Fi

Connecting to your smartphone

- [Preparation for connecting to your smartphone \[68\]](#)
- [Sample smartphone screen display \[69\]](#)
- [Using One-touch Functions to Connect to an NFC-enabled Android Smartphone \[70\]](#)
- [Connecting to a smartphone without using NFC \[71\]](#)

Connecting to the Live-View Remote

- [Connecting a single camera to Live-View Remote \(Single connection\) \[72\]](#)
- [Connecting multiple cameras to Live-View Remote \(Multi connection\) \[73\]](#)

Connecting to Handycam

- [Connecting a single camera to Handycam \(Single connection\) \[74\]](#)
- [Connecting multiple cameras to Handycam \(Multi connection\) \[75\]](#)

Editing images imported to your computer

Using the Action Cam Movie Creator

- [Useful functions of Action Cam Movie Creator \[76\]](#)
- [Installing Action Cam Movie Creator on your computer \[77\]](#)

Others

Recordable time

- [Estimated duration of recording and playback for supplied battery pack \[78\]](#)
- [Estimated recording time of movies \[79\]](#)
- [Estimated number of recordable still images \[80\]](#)

Battery pack

- [On charging the battery pack \[81\]](#)
- [Effective use of the battery pack \[82\]](#)
- [About the remaining battery charge \[83\]](#)
- [How to store the battery pack \[84\]](#)
- [On battery pack life \[85\]](#)

Using the camera abroad

- [On TV color systems \[86\]](#)
- [Countries and regions where you can view images when \[V.SYS\] is set to \[NTSC\] \[87\]](#)
- [Countries and regions where you can view images when \[V.SYS\] is set to \[PAL\] \[88\]](#)
- [The list of time differences for world capitals \[89\]](#)

Precautions

- [Do not use/store the camera in the following places \[90\]](#)
- [On carrying \[91\]](#)
- [Care and storage of the lens \[92\]](#)
- [On cleaning \[93\]](#)

- [On operating temperatures \[94\]](#)
- [On moisture condensation \[95\]](#)
- [Notes on optional accessories \[96\]](#)
- [Note on disposal/transfer of the memory card \[97\]](#)
- [On GPS \[98\]](#)
- [On GPS errors \[99\]](#)
- [On GPS use restriction \[100\]](#)

Specifications

- [Specifications \[101\]](#)

Trademarks

- [Trademarks \[102\]](#)

Notes on License

- [On GNU GPL/LGPL applied software \[103\]](#)

Troubleshooting

List of Default Setting

List of Default Setting

- [List of Default Setting \[104\]](#)

Troubleshooting

Troubleshooting

- [Troubleshooting \[105\]](#)

Battery pack and power

- [Cannot turn on the camera. \[106\]](#)
- [The power turns off suddenly. \[107\]](#)

- [Battery life is short. \[108\]](#)
- [Cannot charge the camera. \[109\]](#)
- [The remaining charge indicator is incorrect. \[110\]](#)

Memory card

- [Operations using the memory card cannot be performed. \[111\]](#)

Shooting images

- [Cannot record images. \[112\]](#)
- [Cannot insert dates on images. \[113\]](#)

Viewing images

- [Cannot playback images. \[114\]](#)
- [The image does not appear on the TV. \[115\]](#)

GPS

- [The camera is not receiving a GPS signal. \[116\]](#)
- [Excessive error in location information. \[117\]](#)
- [It takes time to triangulate although the GPS assist data is taken in. \[118\]](#)
- [The location information has not been recorded. \[119\]](#)

Computers

- [Your computer does not recognize the camera. \[120\]](#)
- [Cannot import images. \[121\]](#)
- [Action Cam Movie Creator cannot be installed. \[122\]](#)
- [Action Cam Movie Creator does not work correctly. \[123\]](#)
- [Cannot play back images on your computer. \[124\]](#)

Wi-Fi

- [It takes too much time to transfer an image. \[125\]](#)

Others

- [The lens gets fogged. \[126\]](#)
- [The camera becomes warm when you use it for a long time. \[127\]](#)
- [The date or time is incorrect. \[128\]](#)

Warning indicators and messages

Warning indicators and error messages

- [Warning indicators and error messages \[129\]](#)

[1] How to use | Read This First | Identifying the parts

Identifying the parts

FDR-X1000V

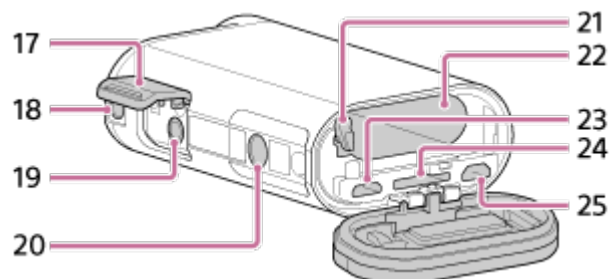
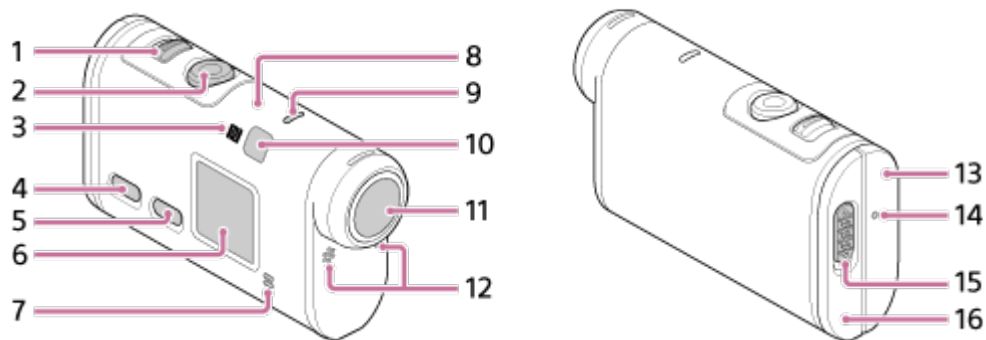

HDR-AS200V

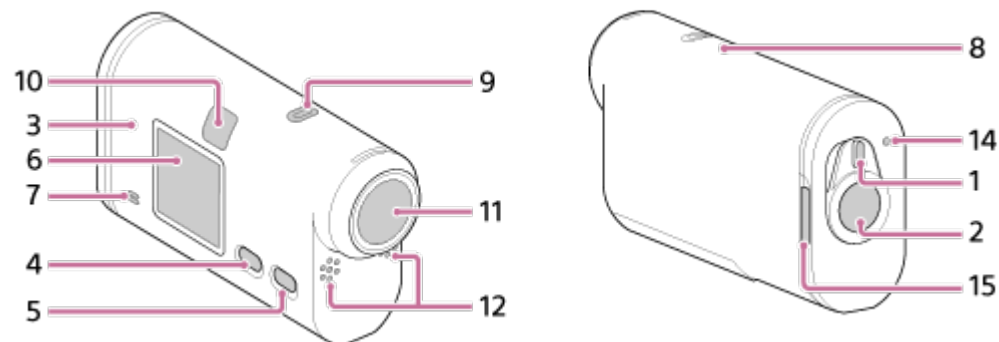

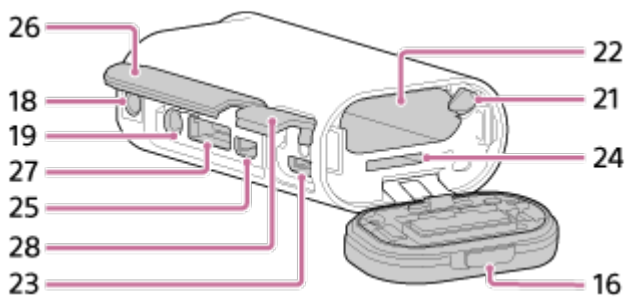

1. REC HOLD switch
2. REC (Movie/Photo) button/ENTER (Menu execute) button
3. **N** (N Mark)
4. PREV (previous menu) button
5. NEXT (next menu) button
6. Display panel
7. Speaker
8. GPS sensor
9. REC/LIVE lamp
10. IR remote receiver
11. Lens
12. Microphones
13. Connector cover (HDMI OUT jack, Multi/Micro USB Terminal) (FDR-X1000V only)
14. REC/access/CHG (Charge) lamp
15. Lock lever
16. Battery pack/memory card cover
17. Connector cover (Mic jack) (FDR-X1000V only)
18. Attachment screw hole for the accessory (FDR-X1000V only)
Tripod adaptor attachment hole (HDR-AS200V only)
19. Mic jack*
20. Screw of the Tripod Adaptor (FDR-X1000V only)
21. Battery ejection lever
22. Battery insertion slot
23. Multi/Micro USB Terminal*
24. Memory card insertion slot
25. HDMI OUT jack
26. Connector cover (HDMI OUT jack, Expansion connector, Mic jack) (HDR-AS200V only)
27. Expansion connector (HDR-AS200V only)
28. Connector cover (Multi/Micro USB Terminal) (HDR-AS200V only)

* When an external microphone (sold separately) is connected, audio cannot be recorded through the built-in microphone.

[2] How to use | Read This First | Screen display

Screen display

The indicators described below are displayed on this camera.



Display icon at 1

- : Wi-Fi function enabled
- : Location information cannot be received because the camera is searching for GPS satellites to receive GPS signals.
- : Recording location information available while triangulating
- : Airplane mode enabled
- : SteadyShot enabled
- : Memory card is not inserted or cannot record to memory card.
- : Battery level indicator of this unit
- **XAVC S** : Movie setting with XAVC S
- **4K** (FDR-X1000V only): Movie setting with 4K
- : Movie setting in the loop recording mode
- **OFF** : Audio recording OFF

Display value at 2

- Resolution and frame rate during movie recording

Display items at 3

- Selected setting items or setting value

Display icons at 4

- : Movie mode
- : Photo mode
- : Interval photo recording mode
- : Live streaming mode

Hint

- The mode icon of the setting target will blink, when changing the settings.

[3] How to use | Getting Started | Checking the bundled items

Checking the bundled items

Make sure that you have following bundled items.
The number in parentheses indicates the quantity of that item bundled.

Camera (1)

Camera is set in the Waterproof Case. Open the cover of the case as illustrated below.

FDR-X1000V

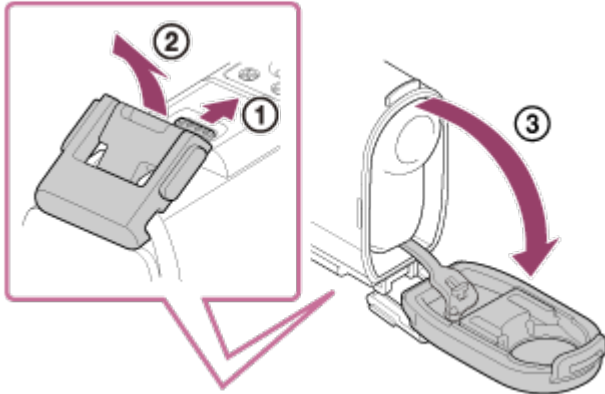

HDR-AS200V

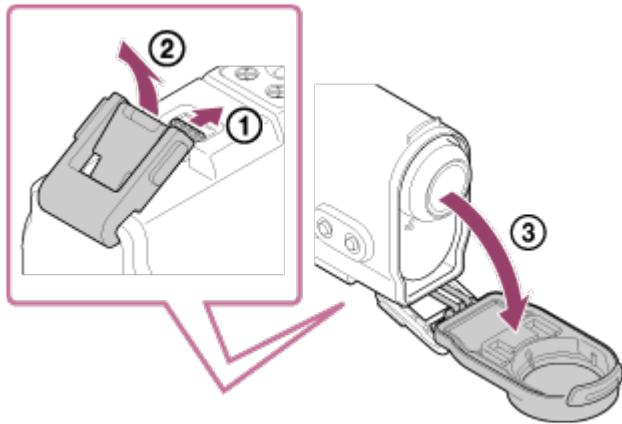

- Micro USB cable (1)

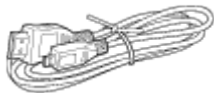

- Rechargeable battery pack (NP-BX1) (1)



- Waterproof Case (1)

FDR-X1000V



HDR-AS200V

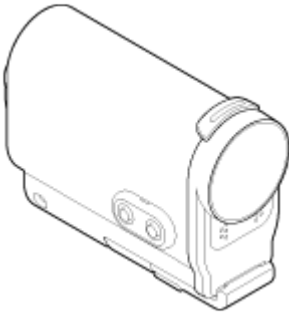

- Attachment Buckle (1)



- Flat Adhesive Mount (1)

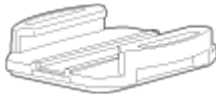

- Curved Adhesive Mount (1)

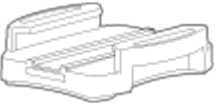

- Tripod adaptor (1) (HDR-AS200V only)



- Startup Guide (1)
- Reference Guide (1)

[4] How to use | Getting Started | Inserting the battery pack

Inserting the battery pack

1. Slide the lock lever to open the battery pack cover.

FDR-X1000V

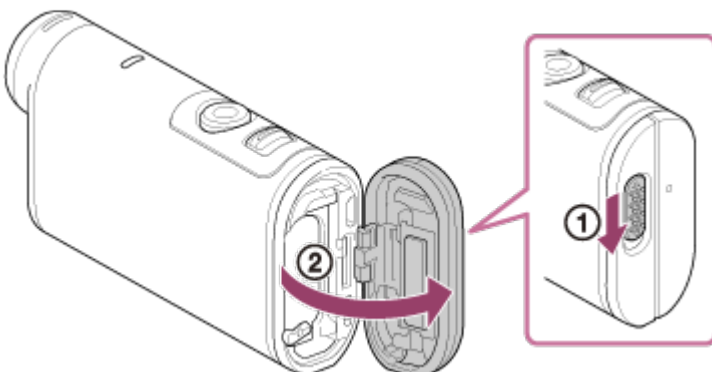

HDR-AS200V

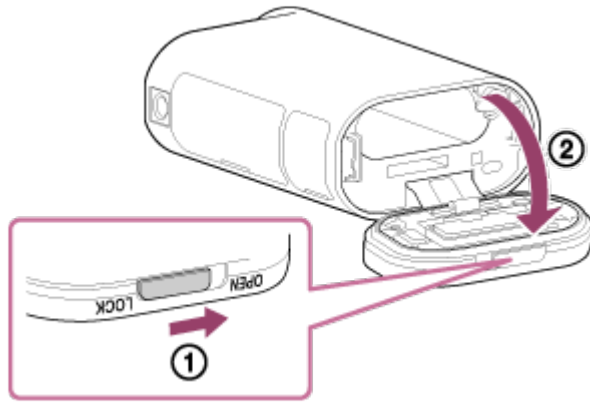

2. Insert the battery pack.

FDR-X1000V

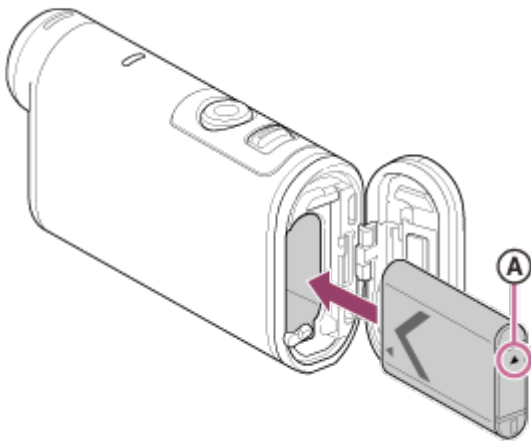

HDR-AS200V

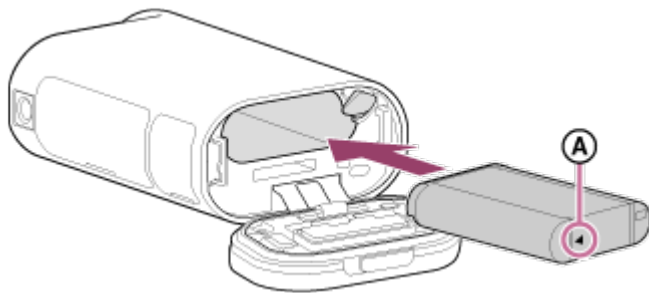

Ⓐ : Align the ▲ mark as illustrated.

3. Close the cover.

- Confirm that the yellow mark on the lock lever is not visible.

To remove the battery pack

Open the cover and slide the battery ejection lever, then remove the battery pack.

To set auto power off function

Select [A.OFF] from the [SETUP] - [CONFIG] screen, then set the auto power off function. The default setting is [60sec]. Change the setting as necessary. For details, see "[Auto power off](#)".

Charging the battery pack

1. Turn off the power of the camera.
 - Charging is not possible when the camera is turned on.
2. Open the connector cover, connect the camera to an activated computer with the micro USB cable (supplied).
 - The REC/access/CHG (Charge) lamp lights in amber.

FDR-X1000V

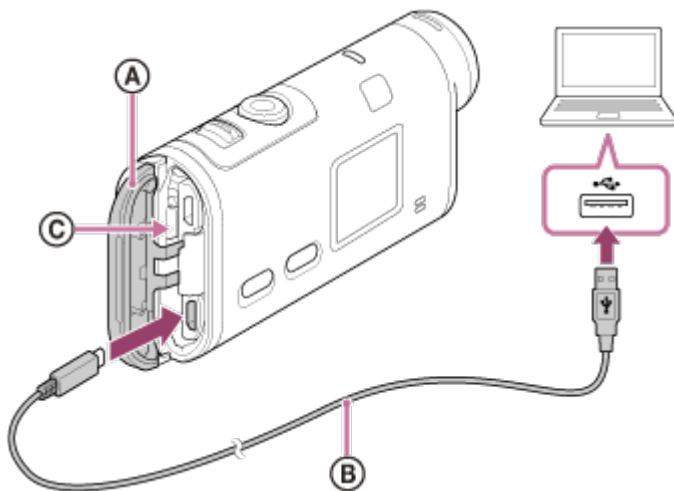

HDR-AS200V

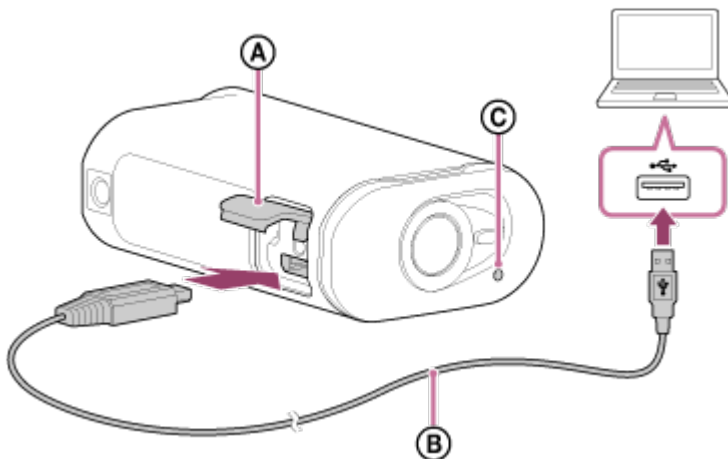

- Ⓐ: Connector cover
- Ⓑ: Micro USB cable
- Ⓒ: REC/access/CHG (Charge) lamp

3. When charging is finished, delete the USB connection between the camera and the computer.
 - Charging is complete when the REC/access/CHG (Charge) lamp turns off (full charge).

The charging time^{*1} of the battery pack NP-BX1 (supplied) is as follows

- Via a computer: Approx. 245 minutes

- Via AC-UD10*² (sold separately): Approx. 175 minutes

*¹ Time required to charge a fully depleted battery pack at a temperature of 25°C (77°F). Charging may take longer under certain circumstances or conditions.

*² Rapid charging is possible by using the USB charger AC-UD10 (sold separately). To connect to the charger, use the micro USB cable (supplied).

Checking the remaining battery charge

A remaining charge indicator appears on the upper right of the display panel.



- The displayed remaining charge indicator may not be correct under certain circumstances.
- It takes about one minute until the correct remaining charge indicator appears.

Note

- You can use only type X battery with this camera.
- Turn off the camera while charging the battery.
- Do not apply force to the camera, when you connect the camera to a computer. This may cause damage to the camera or the computer.
- When you connect the camera to a notebook computer that is not connected to an AC power source, the battery of the notebook computer may be depleted rapidly. Do not leave the camera connected to the computer for a long time.
- Charging the battery pack or the connection with customized or hand-built computers is not guaranteed. Depending on the type of USB device used, charging may not function properly.
- Operation with all computers is not assured.
- If you do not intend to use the camera for an extended period, charge the camera once every 6 to 12 months to maintain battery performance.

[6] How to use | Getting Started | Inserting a memory card

Inserting a memory card

1. Open the cover.
2. Insert the memory card until it clicks.
 - microSD card: Insert in the direction of **A**.
 - Memory Stick Micro™ (M2) media: Insert in the direction of **B**.

FDR-X1000V

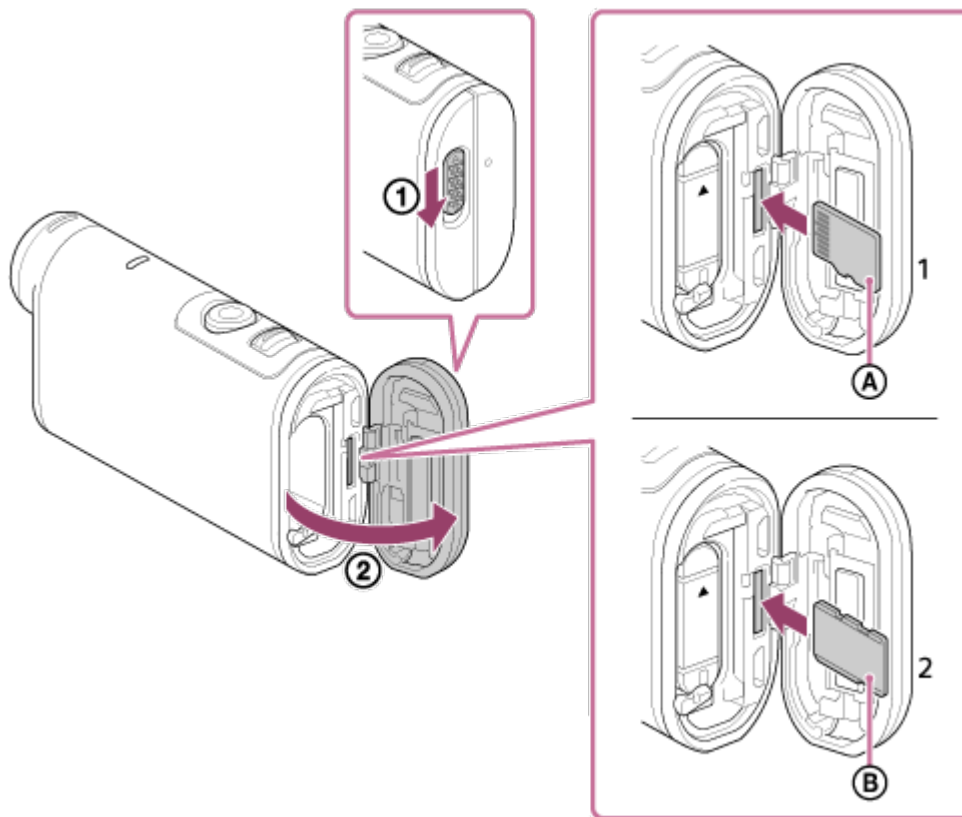

HDR-AS200V

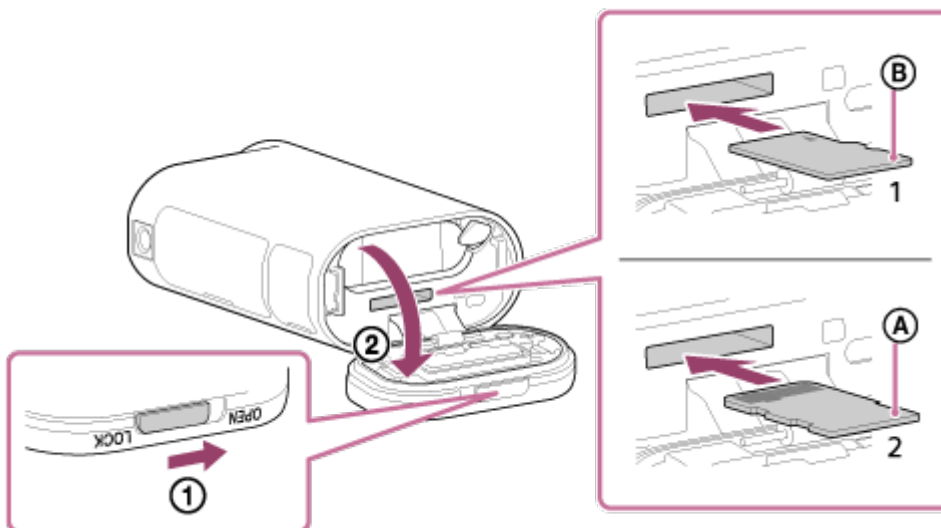

- 1: microSD card
- 2: Memory Stick Micro (Mark2) media
- (A): Terminal side
- (B): Printed side

3. Close the cover.

To eject the memory card

Open the cover, then lightly push the memory card once.

Note

- Insert the memory card properly, confirming each side is facing the correct direction.
- Confirm the direction of the memory card. If you forcibly insert the memory card in the wrong direction, the memory card, memory card slot, or image data may be damaged.
- Format the memory card before use.

- Save important data on the memory card on other media such as a computer, before formatting the memory card.
- Do not insert anything other than the compliant size of memory card into the memory card slot. Otherwise, a malfunction may result.
- When inserting or ejecting the memory card, be careful to prevent the memory card from popping out and dropping.

[7] How to use | Getting Started | Inserting a memory card

The memory cards that can be used with the camera

The memory cards that can be used with the camera are listed below.

SD card

In this guide, microSD memory cards are referred to as microSD card. The microSD memory card that can be used with the camera are as follows.

- microSD memory card
- microSDHC memory card
- microSDXC memory card

Memory Stick media

In this guide, Memory Stick media is referred to as Memory Stick Micro (Mark2) media card. The Memory Stick Micro (Mark2) media that can be used with the camera is as follows.

- Memory Stick Micro (Mark2) media

Note

- Operation with all memory cards is not assured.
- Use an SDXC card faster than Class10 when recording movies in XAVC S.
Use an SDXC UHS-I memory card (U3) when recording movies with 100 Mbps (FDR-X1000V only).
- The capacity of the memory card is up to 64GB.

[8] How to use | Getting Started | Using the Tripod Adaptor

Using the tripod adaptor (HDR-AS200V only)

By attaching the tripod adaptor to the camera, you can attach accessories to the camera without using the waterproof case.

1. Fix the screw of the tripod adaptor in the tripod adaptor attachment hole of the camera.
2. Match the bottom of the camera and fix firmly with the tripod screw in the direction of the arrow.

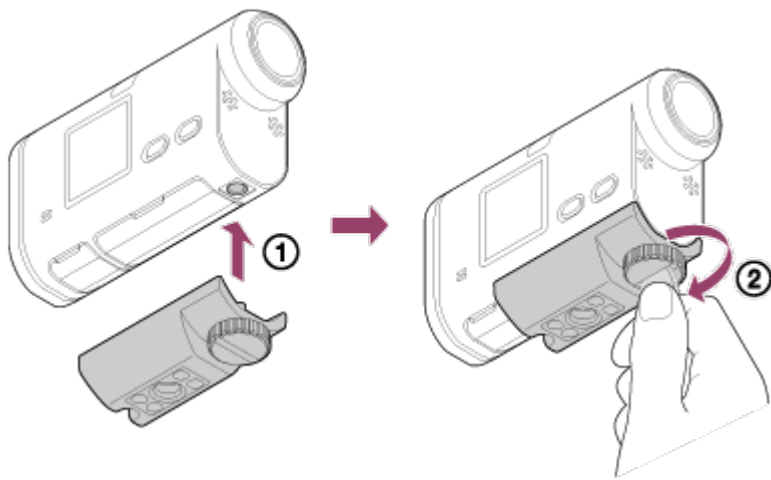

To remove the tripod adaptor

Loosen the screw of the tripod adaptor in the direction of the arrow and remove the tripod adaptor from the camera.

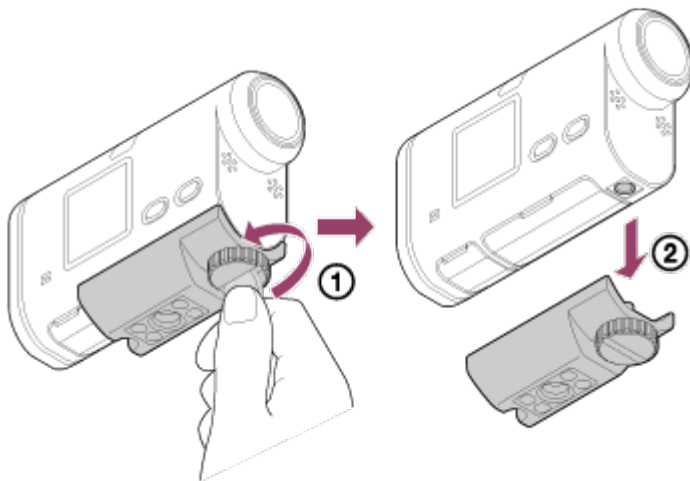

Note

- Attach the waterproof case to the camera when using in water.

[9] How to use | Getting Started | Using the Waterproof Case
Identifying the parts (Waterproof case)

SPK-X1 (supplied with FDR-X1000V)

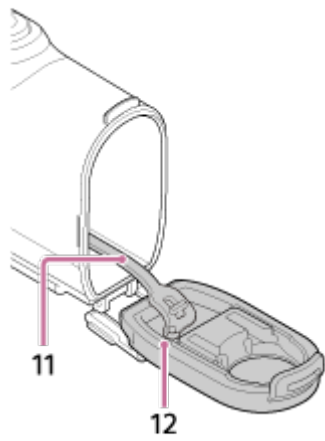
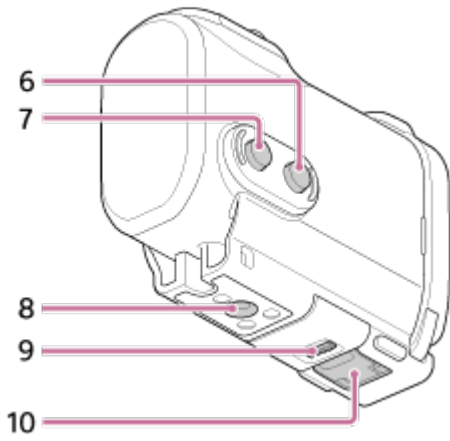
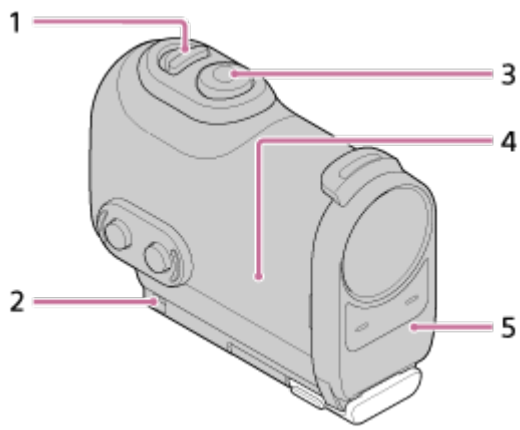

SPK-AS2 (supplied with HDR-AS200V)

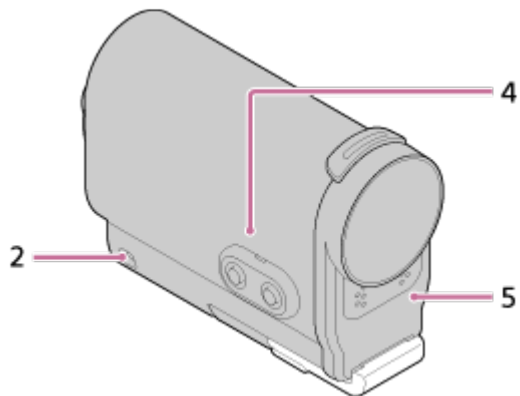

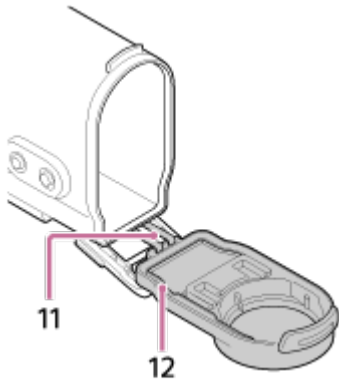
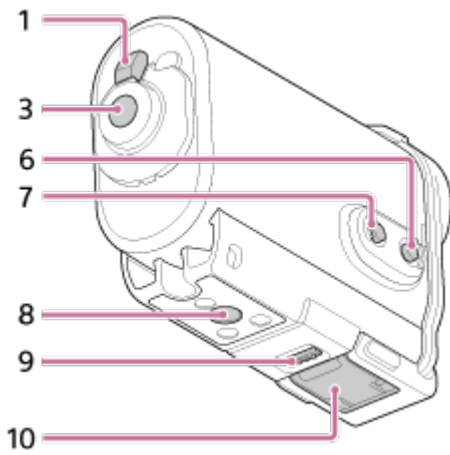

1. REC HOLD (lock) switch
2. Leash attachment hole
3. REC (Movie/Photo) button/ENTER (Menu execute) button
4. Case body
5. Case cover
6. NEXT (next menu) button
7. PREV (previous menu) button
8. Tripod screw hole
9. Buckle lock
10. Buckle
11. Cord
12. Waterproof packing

[10] How to use | Getting Started | Using the Waterproof Case

Using the waterproof case

By inserting the camera in the waterproof case, you can shoot movies at a waterfront.

1. Slide the buckle lock in the direction of ① and hold it, then hold the circled parts and swing out the buckle in the direction of ②.

FDR-X1000V (SPK-X1)

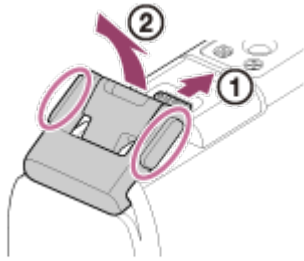

HDR-AS200V (SPK-AS2)

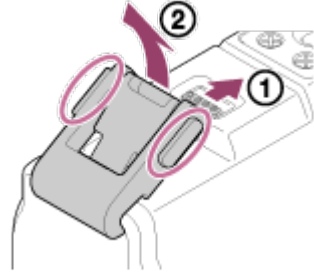

2. Open the case cover.
3. Insert the camera in the case body.
 - Release the REC HOLD (lock) switch on the camera.

FDR-X1000V (SPK-X1)

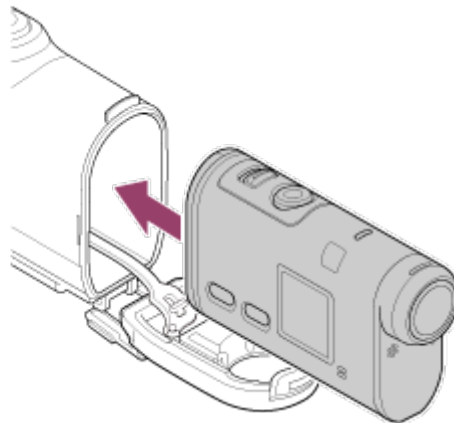
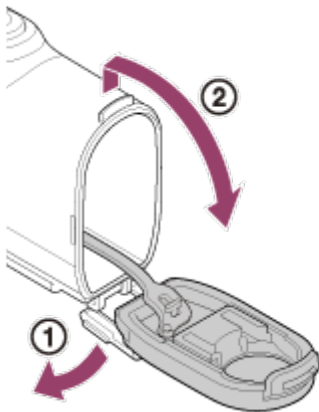

HDR-AS200V (SPK-AS2)

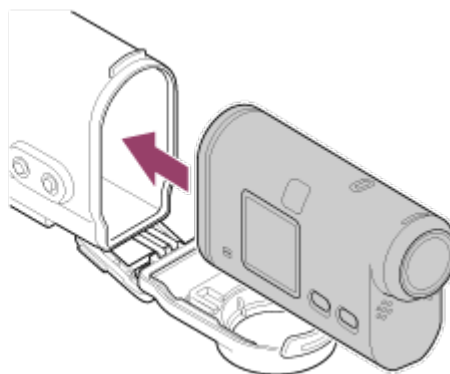
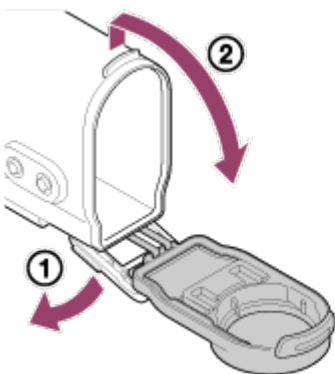

4. Insert the tab of the case body into the slot of the case cover.

FDR-X1000V (SPK-X1)

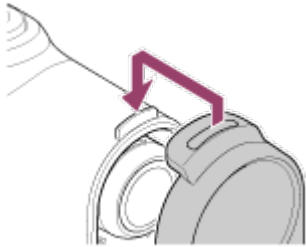

HDR-AS200V (SPK-AS2)

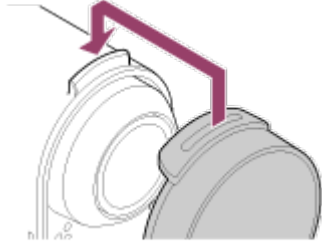

5. Hook the buckle over the tab on the lower part of the case cover ①, then close the buckle in the direction of ②, until it clicks into place.

- Make sure the buckle is locked by the buckle lock.

FDR-X1000V (SPK-X1)

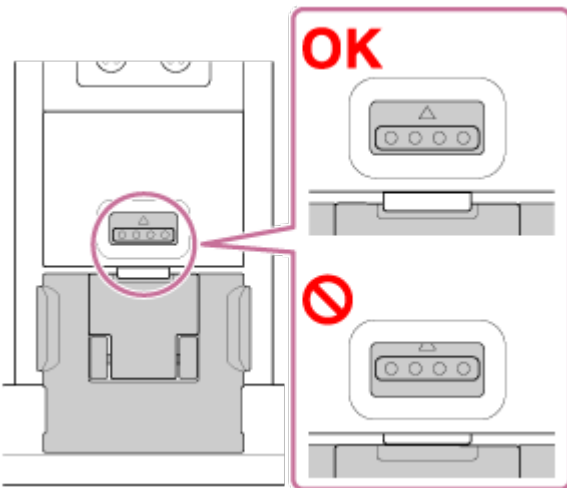
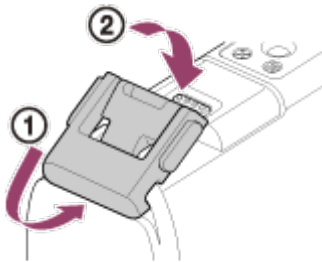

HDR-AS200V (SPK-AS2)

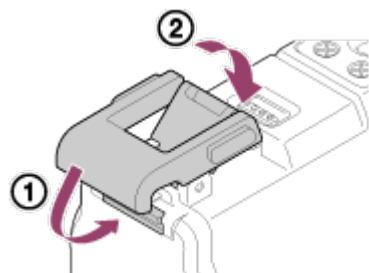

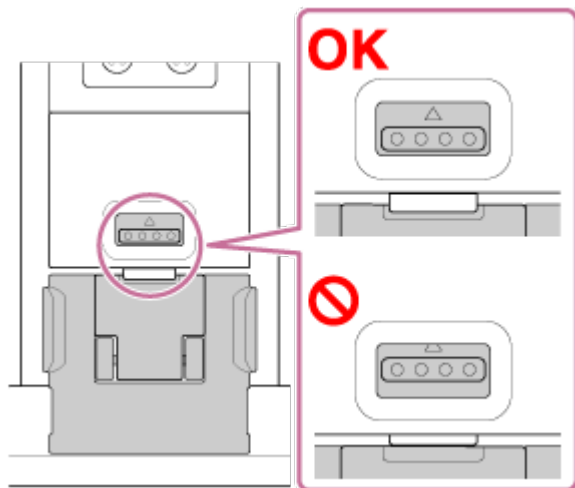

Note

- You cannot operate the REC button when the REC HOLD switch is set to the lock position. Release the lock in the direction of the arrow below, before operation.

FDR-X1000V (SPK-X1)



HDR-AS200V (SPK-AS2)

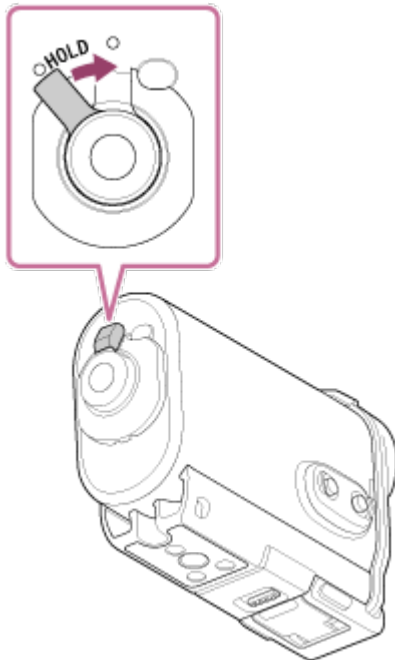

- Since the camera in the waterproof case fails to focus underwater, it is not suitable to shoot images underwater.
- You can record audio while the camera is in the waterproof case, but the sound level is reduced.
- Thread a suitable cord through the leash attachment hole of the waterproof case, then attach the cord to an item you intend to use with the camera.

[11] How to use | Getting Started | Using the Waterproof Case

On waterproof performance of the waterproof case

- When the camera is inserted in the supplied waterproof case, the waterproof performance is as follows.
 - FDR-X1000V (SPK-X1) is operable up to a water depth of 10 m for 60 minutes.
 - HDR-AS200V (SPK-AS2) is operable up to a water depth of 5 m for 30 minutes.
- The waterproof performance is based on the testing standards of our company.
- Do not subject the waterproof case to pressurized water, such as from a tap.
- Do not use the waterproof case in hot springs.
- Use the waterproof case in the recommended operating water temperature range of -10 °C to +40 °C (14 °F to 104 °F).
- Sometimes waterproof performance is lost if the waterproof case is subjected to a strong shock such as from being dropped. We recommend the waterproof case be inspected at an authorized repair shop (chargeable).
- Not to withstand continuous submersion or harsh environmental situations.

Using an anti-fog sheet (AKA-AF1 (sold separately))

- Insert the anti-fog sheet indoors with low humidity.
- Insert the anti-fog sheet in the camera a couple of hours before shooting.
- If you do not use the anti-fog sheet, place it in a bag and keep the top sealed.
- By drying the anti-fog sheet sufficiently, you can use it approximately 200 times repeatedly.

SPK-X1 (supplied with FDR-X1000V)

- When using the optional anti-fog sheet (AKA-AF1), place it in the gap on the opposite side of the camera display.

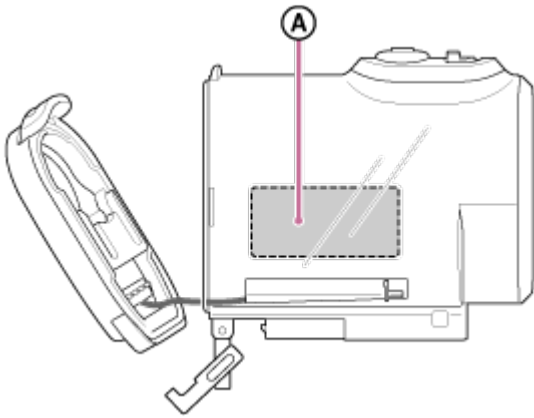

Ⓐ: Anti-fog sheet

SPK-AS2 (supplied with HDR-AS200V)

- When using the optional anti-fog sheet (AKA-AF1), place it in the gap on the bottom of the camera.

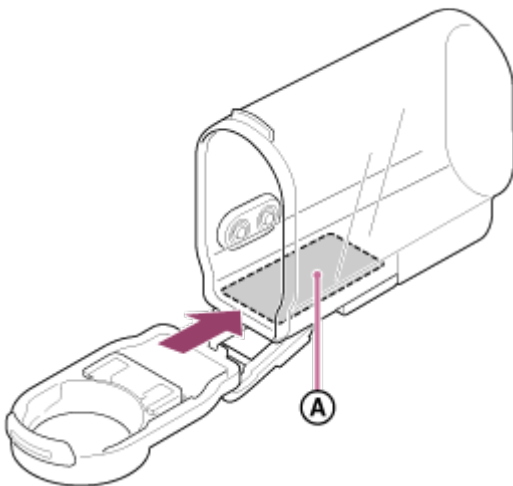

Ⓐ: Anti-fog sheet

[12] How to use | Getting Started | Using the Waterproof Case

Notes on use for the waterproof case

- Do not throw the waterproof case into the water.
- Avoid using the waterproof case under the following situations. In these situations moisture condensation or water leakage may occur and damage the camera.
 - In a very hot or humid place
 - In water hotter than +40°C (104°F)
 - At temperatures lower than –10°C (14°F)
- Do not leave the waterproof case under direct sunlight or in a very hot and humid place for a long period of time. If you cannot avoid leaving the waterproof case under direct sunlight, be sure to cover the waterproof case with a towel or other protection.

- When the camera overheats, it may be automatically turned off or recording may malfunction. To use the camera again, leave it in the cool place for a while to cool down.
 - If sun oil is on the waterproof case, be sure to wash it off thoroughly using lukewarm water. If the waterproof case is left with sun oil on its body, the surface of the waterproof case may become discolored or damaged (such as cracks on the surface).
-

[13] How to use | Getting Started | Using the Waterproof Case

Water leakage

In the unlikely event that a malfunction of the waterproof case causes damage due to water leakage, Sony does not guarantee against damages to the equipment contained in it (camera, battery pack, etc.) and the recorded contents, nor expenses entailed in the photography.

[14] How to use | Getting Started | Using the Waterproof Case

Waterproof packing

This unit uses an waterproof packing to maintain its water resistance. The waterproof packing maintenance is very important. Failure to do waterproof packing maintenance according to the instructions may lead to water leaks and cause this unit to sink.

Inspect the waterproof packing

- Carefully check that there is any dirt, sand, hair, dust, salt, threads, etc., on the waterproof packing. If found, be sure to wipe off with a soft cloth.
 - Lightly run your fingertip around the waterproof packing to check for any invisible dirt.
 - Be careful not to leave any cloth fibers on the waterproof packing after wiping it.
 - Check the waterproof packing for cracks, skewing, distortion, fine splitting, scratches, embedded sand, etc. Replace the waterproof packing if you find any of these.
 - Inspect the waterproof packing contact surface on the case body in the same way.
-

[15] How to use | Getting Started | Using the Waterproof Case

How to check for water leaks

Before installing the camera, always close the waterproof case and immerse it in water to make sure no water leaks in.

When finding a malfunction of waterproof case

If a malfunction is found by inspection of the waterproof packing or check for water leaks, stop using this unit immediately and take it to the nearest Sony dealer.

Maintenance

- After recording in a location with a sea breeze, wash this unit thoroughly in fresh water with the buckle fastened to remove salt and sand, then wipe with a soft dry cloth. It is recommended that you submerge the waterproof case in fresh water for about 30 minutes. If it is left with salt on it, metal portions may be damaged or rust may form and cause water leakage.
- If sun oil is on the waterproof case, be sure to wash it off thoroughly using lukewarm water.
- Wipe the inside of the waterproof case with a soft dry cloth. Do not wash it with water.

Be sure to perform the above maintenance each time you use the waterproof case. Do not use any type of solvent such as alcohol, benzene or thinner for cleaning, as this might damage the surface finish of the waterproof case.

When storing the waterproof case

- To prevent deterioration of the waterproof packing, store the waterproof case in a cool, well-ventilated location. Do not fasten the buckle.
 - Prevent dust from collecting on the waterproof packing.
 - Avoid storing the waterproof case in a cold, very hot or humid place, or together with naphthalene or camphor, as these conditions might damage the waterproof case.
-

Using the adhesive mount

The adhesive mount is used for fixing the waterproof case or tripod adaptor to an item you intend to use. The adhesive mount is a general term for the attachment buckle, flat adhesive mount, and curved adhesive mount. Before attaching, insert the camera in the waterproof case or attach the tripod adaptor.

- The adhesive mount can be attached to the FDR-X1000V without attaching the waterproof case or the tripod adaptor.

The procedure for fixing the adhesive mount to the waterproof case is explained here.

1. Align the tripod screw hole in the bottom of the waterproof case with the tripod screw hole of the attachment buckle, and fix firmly with the tripod screw.

Match the bottom of the camera and fix firmly with the tripod screw.

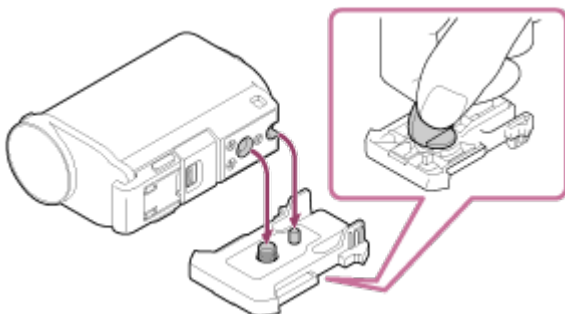

2. Attach the attachment buckle (with the waterproof case set in step 1) to the flat adhesive mount or curved adhesive mount by sliding it until it clicks into place.

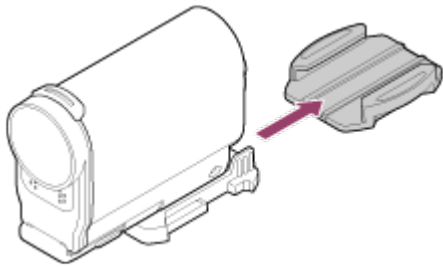

3. Remove dust, moisture and oily substances completely from the surface where the adhesive mount is to be attached.

4. Peel off the release paper on the back, and fix the adhesive mount in the desired location.

Adhesive power reaches its maximum strength 24 hours after the adhesive mount is attached to the desired location.

To attach to or detach from the attachment buckle

Press and hold the circled part to unlock, then slide it in the opposite direction of step 2.

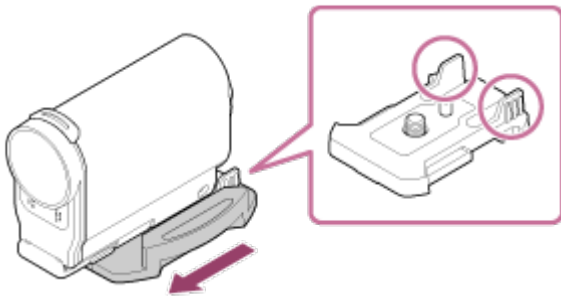

Note

- The flat adhesive mount and curved adhesive mount cannot be used again once they are detached from the location surface.
- When detaching, peel off slowly. If peeled off forcibly, the surface on which the mount is fixed might be damaged.
- Before attaching, check the surface of the item to be used. If it is dirty, or dust, moisture or oily substances are attached, adhesive strength may be impaired and the item could detach with slight impact.
- Use the appropriate adhesive mount (flat or curved) for the surface where the camera will be located. If the mount is not suitable for the surface, it may detach by slight impact.
- Thread a suitable leash through the leash attachment hole of the waterproof case, then attach the leash to an item you intend to use with the camera.
- Before use, confirm that the screw hole on the attachment buckle is not loose, and the flat or curved adhesive mount is securely attached to the surface.

The REC HOLD (lock) switch can prevent accidental operation.

Slide the REC HOLD (lock) switch in the HOLD direction to lock the REC button. To release the lock, slide it in the opposite direction.

- Before recording, release the lock.
- If you lock the camera while recording, the recording state will be kept*.
- If you lock the camera after you stop recording, the stopped state will be kept*.

* Release the lock to change the setting.

FDR-X1000V

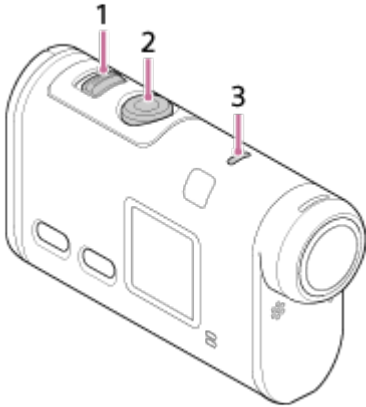

HDR-AS200V

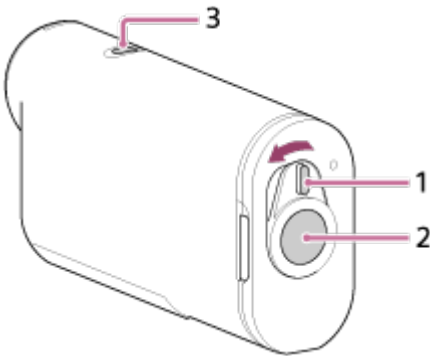

1. REC HOLD (lock) switch
2. REC button
3. REC/LIVE lamp

[19] How to use | Shooting | Shooting movies and still images

Shooting movies (Movie mode)

Record movies.

1. Press the NEXT button or PREV button to turn on the power.
2. Press the NEXT button or PREV button to display [MOVIE].
3. Press the REC button to start shooting.

To stop shooting

Press the REC button during shooting.

Hint

- If you set the mount setting before creating a highlight movie, the number of highlight scene in the movie will increase.

[20] How to use | Shooting | Shooting movies and still images

Shooting still images (Photo mode)

Record still images.

1. Press the NEXT button or PREV button to turn on the power.
2. Press the NEXT button or PREV button to display [PHOTO].
3. Press the REC button to shoot.

[21] How to use | Shooting | Shooting movies and still images

Loop recording mode

The camera continuously keeps shooting in the shooting time set by the loop recording time.

1. Press the NEXT button or PREV button to turn on the power.
2. Press the NEXT button or PREV button to display [LOOP].
3. Press the REC button to start shooting.

To stop shooting

Press the REC button during shooting.

Hint

- The movies and still images before starting loop recording cannot be deleted.
- On the recording media life and the write time
 - If you keep long time recording at a high bit rate in the loop recording mode, the memory card life may be shorter significantly.
If you lower the recording bit rate in long recording, you may minimize bad effects on the memory card life.
 - If you record movies for a long time in the loop recording mode, the data in a memory card may become into smaller parts. Due to the data fragmentation of a memory card, the camera may take time to write and stop movie recording automatically.

Formatting a memory card may improve the recording conditions.

Also, you may minimize bad effects of the data fragmentation by formatting a memory card in advance to increase the free space of memory.

[22] How to use | Shooting | Shooting movies and still images

Interval photo recording mode

The camera records still images at regular intervals until you stop shooting.

1. Press the NEXT button or PREV button to turn on the power.
2. Press the NEXT button or PREV button to display [INTVL].
3. Press the REC button to start shooting.

To stop shooting

Press the REC button during shooting.

[23] How to use | Shooting | Shooting movies and still images

Notes on long-time recording

Describes long-time recording.

- When you continue to shoot for a long time, the temperature of the camera rises. If the temperature reaches above a certain level, shooting stops automatically.
Leave the camera for 10 minutes or longer to allow the temperature inside the camera to decrease to a safe level.
- Under high ambient temperatures, the temperature of the camera rises quickly.
- When the temperature of the camera rises, the image quality may deteriorate. It is recommended that you wait until the temperature of the camera drops before continuing to shoot.
- The surface of the camera may get hot. This is not a malfunction.

[24] How to use | Changing the Settings | List of setting items

List of setting items

List of modes

- LOOP: Loop recording mode
- MOVIE: Movie mode
- PHOTO: Photo mode

- INTVL: Interval photo recording mode
- LIVE: Live streaming mode
- SETUP: Setup mode
- PLAY: Play mode
- PwOFF: Power off

Items you can set in SETUP (Setup mode)

- VMODE: Image quality setting
- V.FMT: Movie format
- STEDY: SteadyShot
- AUDIO: Audio recording
- WIND: Wind noise reduction
- COLOR: Color mode
- L.OPT: Loop recording time
- DRIVE: Still image mode switching
- FPS: Still image shooting interval
- SELF: Self-timer
- ANGLE: Still image angle of view
- LAPSE: Interval photo recording
- FLIP: Flip
- SCENE: Scene
- WB: White balance
- AESFT: AE shift
- CONFIG: Configuration settings

Items you can set in CONFIG (Configuration Settings)

- Wi-Fi: Wi-Fi connection
- GPS: GPS log
- PLANE: Airplane mode
- MOUNT: Mount
- TC/UB: Time Code/User Bit
- IR-RC: IR-Remote Control
- HDMI: HDMI settings
- BGM: Back ground music
- USBPw: USB Power Supply
- A.OFF: Auto power off
- BEEP: Beep
- DATE: Date & time/area setting
- DST: Daylight saving time (Summer time) setting
- LANG: Language setting
- V.SYS: Switching NTSC/PAL
- VER.: Version
- FORMT: Format
- RESET: Resetting the settings

FDR-X1000V

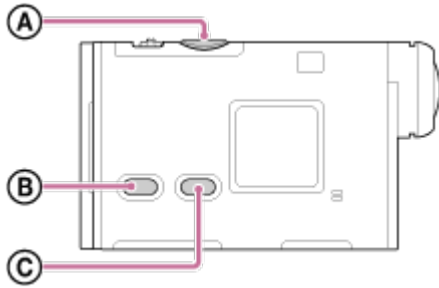

HDR-AS200V

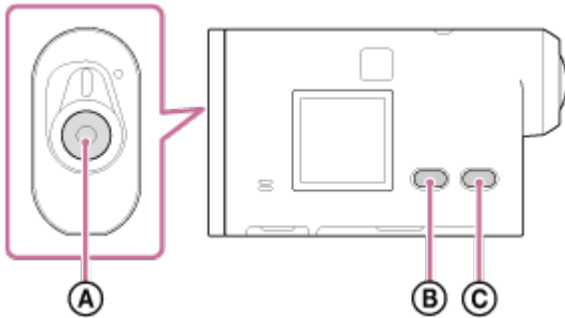

You can set items using the following 3 buttons on the camera.

- **(A)**: REC/ENTER button
Executes the menu
- **(B)**: PREV button
Goes to the previous menu
- **(C)**: NEXT button
Goes to the next menu

1. Press the NEXT button or PREV button to turn on the power.
To power off, press the NEXT button or PREV button to display [PwOFF] and press the ENTER button.
2. Press the NEXT button or PREV button to display [SETUP], then press the ENTER button.
3. Press the NEXT button or PREV button to display the setting item, then press the ENTER button.
To return to the [SETUP] menu, select [BACK] and press the ENTER button.

Hint

- While the setting items are selected, the related icons blink on the display.

[26] How to use | Changing the Settings | Shooting settings

Image quality setting

You can set the image resolution and frame rate for shooting movies and loop recording. Image qualities

that can be set depend on the [V.FMT] setting.

1. Press the NEXT button or PREV button to select [SETUP] - [VMODE], then press the ENTER button.
2. Press the NEXT button or PREV button to select the following settings, then press the ENTER button.

When [V.FMT] is set to [MP4] (recording in MP4)



1080 60p PS

Recorded image: Highest resolution (smooth image recorded at 2x frame rate)

Resolution: 1920x1080

Imaging frame rate^{*1}: 60p/50p

Playback frame rate^{*1}: 60p/50p



1080 30p HQ

Recorded image: Highest resolution

Resolution: 1920x1080

Imaging frame rate^{*1}: 30p/25p

Playback frame rate^{*1}: 30p/25p



720 30p STD

Recorded image: High resolution

Resolution: 1280x720

Imaging frame rate^{*1}: 30p/25p

Playback frame rate^{*1}: 30p/25p



720 120p HS120

Recorded image: High speed recording (smooth image recorded at 4x frame rate)^{*2,*4}

Resolution: 1280x720

Imaging frame rate^{*1}: 120p/100p

Playback frame rate^{*1}: 120p/100p^{*3}



480 240p HS240

Recorded image: High speed recording (smooth image recorded at 8x frame rate)^{*2,*4}

Resolution: 800x480

Imaging frame rate^{*1}: 240p/200p

Playback frame rate^{*1}: 240p/200p^{*3}

When [V.FMT] is set to [HD] (recording in XAVC S)

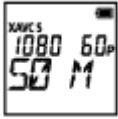

1080 60p 50 M

Recorded image: XAVC S 50 Mbps

Resolution: 1920×1080

Imaging frame rate^{*1}: 60p/50p

Playback frame rate^{*1}: 60p/50p

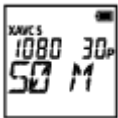

1080 30p 50 M

Recorded image: XAVC S 50 Mbps

Resolution: 1920×1080

Imaging frame rate^{*1}: 30p/25p

Playback frame rate^{*1}: 30p/25p

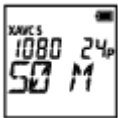

1080 24p 50 M (only when [V.SYS] is set to [NTSC])

Recorded image: XAVC S 50 Mbps

Resolution: 1920×1080

Imaging frame rate: 24p

Playback frame rate: 24p



720 240p 100 M (FDR-X1000V only)

Recorded image: XAVC S 100 Mbps High speed recording^{*2,*4}

Resolution: 1280×720

Imaging frame rate^{*1}: 240p/200p

Playback frame rate^{*1}: 240p/200p^{*3}



720 240p 60 M (FDR-X1000V only)

Recorded image: XAVC S 60 Mbps High speed recording^{*2,*4}

Resolution: 1280×720

Imaging frame rate^{*1}: 240p/200p

Playback frame rate^{*1}: 240p/200p^{*3}



1080 120p 100 M (FDR-X1000V only)

Recorded image: XAVC S 100 Mbps High speed recording ^{*2,*4}

Resolution: 1920×1080

Imaging frame rate ^{*1}: 120p/100p

Playback frame rate ^{*1}: 120p/100p ^{*3}



1080 120p 60 M (FDR-X1000V only)

Recorded image: XAVC S 60 Mbps High speed recording ^{*2,*4}

Resolution: 1920×1080

Imaging frame rate ^{*1}: 120p/100p

Playback frame rate ^{*1}: 120p/100p ^{*3}

When [V.FMT] is set to [4K] (recording in XAVC S) (FDR-X1000V only)



2160 30p 100 M

Recorded image: XAVC S 100 Mbps^{*4}

Resolution: 3840×2160

Imaging frame rate ^{*1}: 30p/25p

Playback frame rate ^{*1}: 30p/25p



2160 30p 60 M

Recorded image: XAVC S 60 Mbps^{*4}

Resolution: 3840×2160

Imaging frame rate ^{*1}: 30p/25p

Playback frame rate ^{*1}: 30p/25p



2160 24p 100 M (only when [V.SYS] is set to [NTSC])

Recorded image: XAVC S 100 Mbps^{*4}

Resolution: 3840×2160

Imaging frame rate: 24p

Playback frame rate: 24p



2160 24p 60 M (only when [V.SYS] is set to [NTSC])

Recorded image: XAVC S 60 Mbps^{*4}

Resolution: 3840×2160

Imaging frame rate: 24p

Playback frame rate: 24p



BACK: Returns to the [VMODE] menu.

^{*1} Frame rate depends on the NTSC/PAL setting.

^{*2} Action Cam Movie Creator™ converts the frame rate to 60p/50p and plays back images at standard speed. It also allows you to play back images in slow motion and edit them during slow motion playback.

^{*3} Depending on your device and software, images are played back at 60p/50p.

^{*4} Steadyshot is disabled and the field angle changes.

Note

- Continuous movie shooting time is approximately 13 hours.
- When you play images recorded in high speed, the frame rate will be 60p/50p, and playback will be standard speed.

[27] How to use | Changing the Settings | Shooting settings

SteadyShot

You can activate the camera-shake reduction when shooting.

1. Press the NEXT button or PREV button to select [SETUP] - [STEDY], then press the ENTER button.
2. Press the NEXT button or PREV button to select the following setting, then press the ENTER button.



ON: Uses SteadyShot (Field angle: 120°).



OFF: Does not use SteadyShot (Field angle: 170°).



BACK: Returns to the [STEDY] menu.

Note

- The field angle is 120° at the default setting. For a wider field angle, set [STEDY] to [OFF].
- The field angle changes when the image quality setting is set to the 4K quality or the high speed recording quality.
- SteadyShot is not effective in the following settings.
 - When the image quality setting mode is set to the 4K quality or the high speed recording quality
 - In the photo mode
 - In the interval photo recording mode

[28] How to use | Changing the Settings | Shooting settings

Flip

You can record the image upside down. This function is useful when the camera is attached upside down.

1. Press the NEXT button or PREV button to select [SETUP] - [FLIP], then press the ENTER button.
2. Press the NEXT button or PREV button to select the following setting, then press the ENTER button.



ON: Flips the image vertically and swaps the left and right sound channels.



OFF: Does not flip the image.



BACK: Returns to the [FLIP] menu.

[29] How to use | Changing the Settings | Shooting settings

Scene

You can select suitable image quality according to the shooting scene.

1. Press the NEXT button or PREV button to select [SETUP] - [SCENE], then press the ENTER button.

2. Press the NEXT button or PREV button to select the following setting, then press the ENTER button.



NORML: Shoots images in the standard quality.



WATER: Shoots images in an image quality suitable for underwater shooting.



BACK: Returns to the [SCENE] menu.

Note

- If you select [WATER], you cannot set the white balance.
- Dive Door (AKA-DDX1(sold separately)) is required for underwater shooting. (FDR-X1000V only)
- Underwater Housing (MPK-AS3(sold separately)) is required for underwater shooting. (HDR-AS200V only)

[30] How to use | Changing the Settings | Shooting settings

White balance

You can adjust the color balance to the recording environment.

1. Press the NEXT button or PREV button to select [SETUP] - [WB], then press the ENTER button.
2. Press the NEXT button or PREV button to select the following setting, then press the ENTER button.



AWB: Adjusts the white balance automatically so that the colors appear natural.



CTEMP: Adjusts for the color temperature of the light source (from 2500K to 9900K).



CUSTM: Uses the setting acquired in C.SET.



C.SET: Acquires the base white color for shooting under the light source.

Place a white reference object under the same lighting conditions as the subject and press the REC/ENTER button.



BACK: Returns to the [WB] menu.

Note

- If you set [SCENE] to [WATER], you cannot set the white balance.

[31] How to use | Changing the Settings | Shooting settings

AE shift

You can adjust the exposure according to your preference.

1. Press the NEXT button or PREV button to select [SETUP] - [AESFT], then press the ENTER button.
2. Press the NEXT button or PREV button to select the following setting, then press the ENTER button.



0.0: Does not use the AE shift.



+0.3: Uses the AE shift (Set +0.3EV for example).

- Select the preset value on this unit, then press the ENTER button.



BACK: Returns to the [AESFT] menu.

[32] How to use | Changing the Settings | Shooting settings

Color mode

You can change the image color tone when shooting movie/loop recording/Live streaming.

1. Press the NEXT button or PREV button to select [SETUP] - [COLOR], then press the ENTER button.
2. Press the NEXT button or PREV button to select the following setting, then press the ENTER button.



NUTRL: Records in natural colors.



VIVID: Records in vivid colors.



BACK: Returns to the [COLOR] menu.

Note

- If you shoot with [NUTRL], the image contrast may appear low. This is not a malfunction.

[33] How to use | Changing the Settings | Shooting settings

Movie format

Select the movie format for shooting movies or loop recording.

1. Press the NEXT button or PREV button to select [SETUP] - [V.FMT], then press the ENTER button.
2. Press the NEXT button or PREV button to select the following setting, then press the ENTER button.



4K: Records a 4K (XAVC S) movie (FDR-X1000V only).

- Select the desired image quality.



HD: Records a HD movie.

- Select the desired image quality.



MP4: Records an MP4 movie.

- Select this setting if you want to upload to your smartphone or a website.



BACK: Returns to the [V.FMT] menu.

[34] How to use | Changing the Settings | Shooting settings

Audio recording setting

Set ON/OFF of the audio recording.

1. Press the NEXT button or PREV button to select [SETUP] - [AUDIO], then press the ENTER button.
2. Press the NEXT button or PREV button to select the following setting, then press the ENTER button.



ON: Records sound when shooting a movie.



OFF: Does not record sound when shooting a movie.



BACK: Returns to the [AUDIO] menu.

[35] How to use | Changing the Settings | Shooting settings

Wind noise reduction

This function automatically cuts low-range wind noise according to the noise level when recording using the built-in microphone.

1. Press the NEXT button or PREV button to select [SETUP] - [WIND], then press the ENTER button.
2. Press the NEXT button or PREV button to select the following setting, then press the ENTER button.



ON: Cuts low-range to reduce wind noise.



OFF: Does not reduce wind noise.



BACK: Returns to the [WIND] menu.

Note

- This function does not activate while an external microphone is connected to this product.

[36] How to use | Changing the Settings | Shooting settings

Loop recording time

Set the loop recording time.

1. Press the NEXT button or PREV button to select [SETUP] - [L.OPT], then press the ENTER button.
2. Press the NEXT button or PREV button to select the following setting, then press the ENTER button.

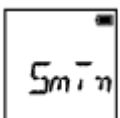

5min: Sets the loop recording time to 5 minutes.
The size of created movie is one minute per file.

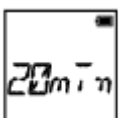

20min: Sets the loop recording time to 20 minutes.
The size of created movie is five minutes per file.

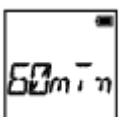

60min: Sets the loop recording time to 60 minutes.

The size of created movie is 15 minutes per file.



120mn: Sets the loop recording time to 120 minutes.
The size of created movie is 15 minutes per file.



UNLIM: Keeps recording continuously up to the limit of free space of a memory.
The size of created movie is 15 minutes per file. The movie file is created up to the limit of free space of a memory.



BACK: Returns to the [L.OPT] menu.

Hint

When [L.OPT] is set to [5min]

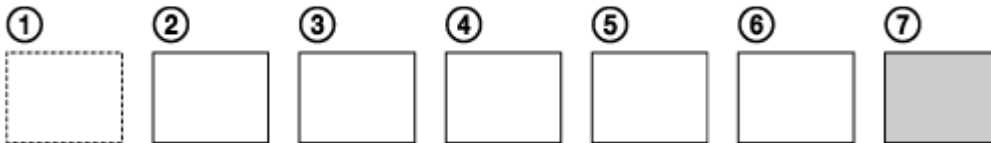

- The movie files of one minute per file are created in order.
- When the recording time exceeds five minutes, the sixth movie file (⑥) is created.
- Before creating the seventh file (⑦), the camera deletes the first movie file (①) and keeps recording.

[37] How to use | Changing the Settings | Shooting settings

Still image angle of view

You can configure the angle of view of the camera for shooting still images. This setting is available only when in the photo mode or the interval photo recording mode.

1. Press the NEXT button or PREV button to select [SETUP] - [ANGLE], then press the ENTER button.
2. Press the NEXT button or PREV button to select the following setting, then press the ENTER button.



170°: Records with a field angle of 170°.



120°: Records with a field angle of 120°.



BACK: Returns to the [ANGLE] menu.

[38] How to use | Changing the Settings | Shooting settings

Still image mode switching

You can set the mode for still image recording.

1. Press the NEXT button or PREV button to select [SETUP] - [DRIVE], then press the ENTER button.
2. Press the NEXT button or PREV button to select the following setting, then press the ENTER button.



SINGL: Single shooting (Image size/5.4M)

- Shoots a single still image.



BURST: Burst shooting (Image size/5.4M)

- Shoots at the continuous shooting interval set in the still image shooting interval [FPS].



MSHOT: Motion Shot LE (Image size/2.2M)

- Generates a still image from still images continuously shot at the interval set in the still image shooting interval [FPS].



BACK: Returns to the [DRIVE] menu.

To shoot successfully in Motion Shot LE mode

Try the following shooting methods.

- Stabilize the camera to prevent camera shake.
- Use the remote control function with a smartphone or Live-View Remote, or the self-timer function to prevent camera shake for better results.
- Make sure that the moving objects are not too large or too many.
- Shoot in a bright location and avoid changes in brightness.

To shoot successfully in burst shooting mode

Try the following shooting methods.

- Stabilize the camera to prevent camera shake.
- Use the remote control function with a smartphone or Live-View Remote, or the self-timer function to prevent camera shake for better results.

Note

- If automatic generation in Motion Shot LE mode fails, [FAIL] is displayed on the display panel. Depending on the display timing of [FAIL], the image may not be saved.
- After shooting with Burst Shooting or Motion Shot LE mode, there is a processing time during which the next operation cannot be operated.
- Only one still image can be transferred to the smartphone.
(In burst shooting mode, the last still image can be transferred. In Motion Shot LE mode, the generated image can be transferred.)

[39] How to use | Changing the Settings | Shooting settings

Still image shooting interval

You can select the continuous shooting setting for using burst shooting or Motion Shot LE.

1. Press the NEXT button or PREV button to select [SETUP] - [FPS], then press the ENTER button.
2. Press the NEXT button or PREV button to select the following setting, then press the ENTER button.



10f1s: Shoots 10 still images in a second.

- Suitable for shooting fast-moving objects.

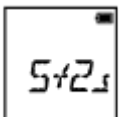

5f2s: Shoots 5 still images in 2 seconds.

- Suitable for action shots of objects.



2f5s: Shoots 2 still images in 5 seconds.

- Suitable for shooting slow-moving objects.



BACK: Returns to the [FPS] menu.

Note

- [10f1s], [5f2s], [2f5s] are estimates of the maximum speed. The maximum speed may not be reached depending on the shooting conditions.

[40] How to use | Changing the Settings | Shooting settings

Self-timer

You can use self-timer when shooting still images.

1. Press the NEXT button or PREV button to select [SETUP] - [SELF], then press the ENTER button.
2. Press the NEXT button or PREV button to select the following setting, then press the ENTER button.



OFF: Does not use self-timer.



2sec: Sets the self-timer to 2-second.



10sec: Sets the self-timer to 10-second.



BACK: Returns to the [SELF] menu.

Note

- You cannot use self-timer when recording movies.
- The self-timer function is enabled until it is cancelled. Set the self-timer to [OFF] after you finish using it.

Interval photo recording

You can select the time lapse setting for the interval photo recording mode.

1. Press the NEXT button or PREV button to select [SETUP] - [LAPSE], then press the ENTER button.
2. Press the NEXT button or PREV button to select the following setting, then press the ENTER button.



1sec: Continues to record still images at about 1-second intervals.



2sec: Continues to record still images at about 2-second intervals.



5sec: Continues to record still images at about 5-second intervals.



10sec: Continues to record still images at about 10-second intervals.



30sec: Continues to record still images at about 30-second intervals.



60sec: Continues to record still images at about 60-second intervals.



BACK: Returns to the [LAPSE] menu.

Note

- The first photo is recorded immediately when recording starts, without waiting for the completion of the set interval. The second and subsequent still images are recorded at the set intervals.

Wi-Fi connection

You can operate the camera by using compatible devices (Live-View Remote, smartphone, etc.) connected to the camera via Wi-Fi.

1. Press the NEXT button or PREV button to select [SETUP] - [CONFIG] - [Wi-Fi], then press the ENTER button.
2. Press the NEXT button or PREV button to select the following setting on the camera, then press the ENTER button.



ON: Operates a single camera with the compatible device.



OFF: Does not operate a camera with the compatible device.



MULTI: Operates multiple cameras with the compatible device.

- **NEW:** Select [NEW] when you connect to the compatible device for the first time.
- **CRRNT:** Select [CRRNT] when you connected to the compatible device before.



BACK: Returns to the [Wi-Fi] screen.

3. Displays [MOVIE], [LOOP], [PHOTO] or [INTVL].
4. Connect the camera to the compatible device via Wi-Fi.
5. Operate the camera with the compatible device.

Note

- Battery consumption is quicker when you operate the camera with the compatible device.
- [CRRNT] in [MULTI] does not appear when you connect to the compatible device for the first time.
- The camera should only be connected to the devices described in "Using the camera connected to other devices via Wi-Fi" via Wi-Fi, and should not be connected to other Wi-Fi access points. If you choose to connect the camera to other Wi-Fi access points, then you do so at your own risk. In such

cases, the camera may be subject to unauthorized access, and any communication could be intercepted.

[43] How to use | Changing the Settings | Camera settings

GPS log

You can record the location information and the movement speed while recording movies using the camera's GPS function.

Action Cam Movie Creator™ allows you to import movies recorded with GPS log to your computer and view them with a map showing movement speed and tracking actions.

1. Press the NEXT button or PREV button to select [SETUP] - [CONFIG] - [GPS], then press the ENTER button.
2. Press the NEXT button or PREV button to select the following setting, then press the ENTER button.



ON: Records movies with the GPS log or still images with location information.



OFF: Does not use GPS log.



BACK: Returns to the [GPS] menu.

Checking triangulating status

The indicator changes according to the strength of GPS signal reception when GPS is activated.

- **No indicator (OFF):** The GPS log is set to [OFF] or an error occurred.
- **✖ (Searching/Difficult):** Your camera is searching for GPS satellites. (It may take several minutes to start triangulating.)
- **✖ (Triangulating):** Your camera is receiving a GPS signal. (Your camera can record location information.)

About GPS assist data

The time for the GPS acquiring location information can be shortened by taking in GPS assist data. If connection via Internet is made using the software, Action Cam Movie Creator, the GPS assist data can be updated automatically.

- If the Date & Time Setting is not set, or set time is shifted greatly, the time for the GPS acquiring location information cannot be shortened.
- If the term of validity of GPS assist data has run out, the time for the GPS acquiring location information cannot be shortened.

Using the support tool

You can also update the GPS assist data by inserting a memory card into the computer. Display the camera setting's screen of Action Cam Movie Creator, select "Update GPS Assist Data" - the desired memory card drive to be installed on your computer, and then update the GPS assist data. If you insert this memory card into the camera, the GPS assist data will be reflected on the camera.

Note

- GPS log is recorded only when recording movies. When you shoot still images, only the location information is recorded.
- If you do not record the location information, set the GPS log to [OFF].
- During takeoff and landing of an airplane, set the airplane mode to [ON].
- Use GPS in accordance with the regulations of the place or situation.
- It may take from several tens of seconds to several minutes to record the location information when you use the GPS for the first time or use it again after long intervals. Triangulating time can be shortened by taking in GPS assist data.
- Do not cover the GPS sensor with your finger when searching for GPS satellites or when triangulating. This decreases the sensitivity of the GPS sensor and triangulation may fail.
- Sony does not collect location information and routing information.
- To display location information and routing information as a map on a computer, Sony provides data of location information and routing information to Google Inc.
- Although the camera does not have the function to delete log files, you can delete them by formatting the media.
- The maximum number of log files that can be recorded is 256/day. When the maximum number of recorded log files is reached, you can continue to shoot images, but cannot record log files.

[44] How to use | Changing the Settings | Camera settings

Airplane mode

When you are in an airplane or another restricted place, you can set the camera to temporarily disable all functions related to the wireless applications such as Wi-Fi/GPS, etc. If you set the airplane mode to [ON], an airplane mark will be displayed on the display panel.

1. Press the NEXT button or PREV button to select [SETUP] - [CONFIG] - [PLANE], then press the ENTER button.
2. Press the NEXT button or PREV button to select the following setting, then press the ENTER button.



ON: Select this when you are on board an airplane (The Wi-Fi/GPS function is disabled).



OFF: Select this for normal use (The Wi-Fi/GPS function is enabled).



BACK: Returns to the [PLANE] menu.

[45] How to use | Changing the Settings | Camera settings

Mount

Register the place of installation to the camera in advance.

If you start shooting after registering the place of installation, the camera will detect every highlighted scene allowing you to make an appealing highlight movie with the Highlight Movie Maker.

1. Press the NEXT button or PREV button to select [SETUP] - [CONFIG] - [MOUNT], then press the ENTER button.
2. Press the NEXT button or PREV button to select the following setting, then press the ENTER button.



BODY: Select this function when the camera is attached to the person shooting the movie.

- Mount example: head mount, chest mount, backpack mount, wrist mount, monopod



OTHER: Select this function when the camera is attached to a board, bicycle, etc.

- Mount example: roll bar mount, handle bar mount, surfboard mount, suction cup mount



BACK: Returns to the [MOUNT] menu.

[46] How to use | Changing the Settings | Camera settings

Time Code/User Bit

About time code

Time code is a useful function for advanced image editing, which records hours/minutes/seconds/frames on the image data.

About user bit

User bit is a function that can record information (8-digit hexadecimal numbers) such as date/time/scene number. This function is useful for editing movies created using two or more cameras.

1. Press the NEXT button or PREV button to select [SETUP] - [CONFIG] - [TC/UB], then press the ENTER button.
2. Press the NEXT button or PREV button to select [DISP], [TCSET] or [UBSET], then press the ENTER button.

When selecting [DISP]



TC: Displays the time code.



U-BIT: Displays the user bit.



OFF: Does not display the time code/user bit.

When selecting [TCSET]



PrSet: Sets the time code.

- Set four 2-digit numbers, then press the ENTER button.
- The time code can be selected within the following range.
 - When selecting 30p or 60p
00:00:00:00 - 23:59:59:29
 - When selecting 25p or 50p
00:00:00:00 - 23:59:59:24
 - When selecting 24p, you can set the last 2 time code digits of the frames in multiples of 4, between 0 and 23.



RESET: Initializes the time code.

Press the ENTER button to display [SURE?] while [OK] is displayed, then press the ENTER button again.



FORMAT: Selects the time code recording method.

- **DF:** Records the time code in drop frame.
- **NDF:** Records the time code in non-drop frame.
- In the following situations, the time code is fixed to [NDF].
 - When [VMODE] is set to 24p
 - When [V.SYS] is set to [PAL]



RUN: Sets how the time code advances.

- **REC:** The time code advances only while recording XAVC S movies. It is recorded sequentially from the time code on the image recorded last time.
- **FREE:** The time code advances sequentially, regardless of the operation of the camera.



MAKE: Sets the time code to be recorded.

- **PrSet:** The newly set-up time code is recorded on recording media.
- **REGEN:** The last time code of the previous recording is read out from the recording media and the new time code is recorded sequentially from the last time code.



BACK: Returns to the [TCSET] menu.

When selecting [UBSET]



PrSet: Sets the user bit.

- Set four 2-digit numbers, then press the ENTER button.
- The user bit can be selected within the following range.
 - _ 00 00 00 00 - FF FF FF FF



RESET: Initializes the user bit.

- Press the ENTER button to display [SURE?] while [OK] is displayed, then press the ENTER button again.



T.REC: Sets the recording time of the user bit.

- **OFF:** Does not record the time as a user bit.
- **ON:** Records the time as a user bit.



BACK: Returns to the [UBSET] menu.

Note

- When [V.FMT] is set to [MP4], [TC/UB] is not available.

[47] How to use | Changing the Settings | Camera settings IR-Remote Control

You can start/stop recording and initialize the time code using the infrared remote control (RMT-845 (sold separately)).

1. Press the NEXT button or PREV button to select [SETUP] - [CONFIG] - [IR-RC], then press the ENTER button.
2. Press the NEXT button or PREV button to select the following setting, then press the ENTER button.



ON: Allows you to operate the camera using the infrared remote control.



OFF: Prevents operation of the camera using the infrared remote control.



BACK: Returns to the [IR-RC] menu.

Note

- The infrared remote control RMT-845 (sold separately) is required to use this function.

Purchase it at a Sony service center.

- You can operate only the following settings using the RMT-845 (sold separately). Other settings are inoperable.
 - Initialize the time code.
When initializing the setting, the REC lamp lights in blue.
 - Start/stop recording.

[48] How to use | Changing the Settings | Camera settings

HDMI settings

Set the HDMI output signal.

1. Press the NEXT button or PREV button to select [SETUP] - [CONFIG] - [HDMI], then press the ENTER button.
2. Press the NEXT button or PREV button to select the following setting, then press the ENTER button.



RESOL: Sets the output resolution of the HDMI signal.

- AUTO: Sets the HDMI resolution signal automatically.
- 2160p (FDR-X1000V only): Sets the HDMI resolution signal to 2160p.
- 1080p: Sets the HDMI resolution signal to 1080p.
- 1080i: Sets the HDMI resolution signal to 1080i.
- 720p: Sets the HDMI resolution signal to 720p.
- BACK: Returns to the [HDMI] menu.



24/60: Sets the output HDMI signal frame rate.

- 60p: Output HDMI signal is 60p.
- 24p: Output HDMI signal is 24p.
- BACK: Returns to the [24/60] menu.

* Available only when in movie mode (not available when playback).

* This setting is disabled when VMODE is set to a setting other than 1080 24p.

* This setting is disabled when the HDMI resolution is set to a setting other than 1080.



TCOUT: Sends the time code or the user bit information to a device connected with HDMI.

- ON: Sends the time code or user bit information.

- OFF: Does not send the time code or user bit information.
- BACK: Returns to the [TCOUT] menu.

* Unavailable when [V.FMT] is set to [MP4].



R.CTL: Controls the recording on a device connected with HDMI.

- ON: Controls the recording on the device.
- OFF: Does not control the recording on the device.
- BACK: Returns to the [R.CTL] menu.

* Unavailable when [V.FMT] is set to [MP4].



BACK: Returns to the [HDMI] menu.

[49] How to use | Changing the Settings | Camera settings USB Power Supply

When connecting the camera to a computer or USB device with the micro USB cable (supplied), the camera can be set so the connected device supplies power to it.

1. Press the NEXT button or PREV button to select [SETUP] - [CONFIG] - [USBPw], then press the ENTER button.
2. Press the NEXT button or PREV button to select the following setting, then press the ENTER button.



ON: Supplies power from a connected device, through the micro USB cable.



OFF: Does not supply power from a connected device, through the micro USB cable.



BACK: Returns to the [USBPw] menu.

- If you change the setting of the USB power supply while the micro USB cable is connected, disconnect the cable, then reconnect.
- Power may not be supplied properly from a USB device with a power supply capacity of less than 1.5 A.
- If you turn the power of the camera on while charging the battery pack, charging stops and power is supplied to the camera from a device connected via USB.
- You can shoot and playback images using USB Power supply, however the battery pack is not charged simultaneously.

How to supply power from a wall outlet (wall socket)

Use the USB charger AC-UD10 (sold separately). To connect the camera to the charger, use the micro USB cable (supplied).

[50] How to use | Changing the Settings | Camera settings

Auto power off

You can change the setting of the auto power off function.

1. Press the NEXT button or PREV button to select [SETUP] - [CONFIG] - [A.OFF], then press the ENTER button.
2. Press the NEXT button or PREV button to select the following setting, then press the ENTER button.



20sec: Turns the power off after about 20 seconds.



60sec: Turns the power off after about 60 seconds.



OFF: Does not turn off automatically.



BACK: Returns to the [A.OFF] menu.

Note

- Auto power off is not available in the following situations.
 - When recording data to media

- When shooting movies, or shooting in Interval photo recording mode
 - During movie playback
 - When Wi-Fi connection is being established, Wi-Fi remote control is connected, an image is being uploaded to a smartphone, or live streaming
 - HDMI connection is being made.
 - Supplying power from a connected USB device
 - Connecting a mass storage device
 - IR-remote control is set to ON.
- In the following cases, even if you have selected [20sec] or [60sec] in the auto power off function, the time that elapses before the power turns off will be extended.
 - While adjusting [SETUP] settings
 - While playing back still images
 - When [Wi-Fi] is set to [ON] and the Wi-Fi icon is displayed.

[51] How to use | Changing the Settings | Camera settings

Beep

You can set the audible notification of operations ON/OFF.

1. Press the NEXT button or PREV button to select [SETUP] - [CONFIG] - [BEEP], then press the ENTER button.
2. Press the NEXT button or PREV button to select the following setting, then press the ENTER button.



ON: All operation sounds are enabled.



SILNT: Operation sounds are emitted for the following operations only.

- Power turned on
- Recording started
- Recording stopped
- Shutter pressed
- A disabled operation was selected or an error occurred
- Wi-Fi connection confirmation beep



OFF: All operation sounds are disabled.



BACK: Returns to the [BEEP] menu.

[52] How to use | Changing the Settings | Camera settings

Date & time/area setting

You can set the year/month/day and region.

1. Press the NEXT button or PREV button to select [SETUP] - [CONFIG] - [DATE], then press the ENTER button.
2. Press the NEXT button or PREV button to select the desired date, time and region, then press the ENTER button to confirm.



2015 (default): Sets the year.



01 (default): Sets the month.



01 (default): Sets the day.



00 (default): Sets the hour.



00 (default): Sets the minutes.



GMT+0 (default): Sets the region in which you use the camera. (Regions are defined by time difference from Greenwich Mean Time (GMT)).

Setting the region

You can set the clock to the local time of a country you visit by selecting the region.

Regions are defined by time difference from Greenwich Mean Time (GMT). Refer also to "[The list of time differences for world capitals](#)".

Note

- Select 00:00 for midnight, 12:00 for noon.
- When you set the GPS log to [ON], the camera adjusts date, time and region automatically during shooting mode.

[53] How to use | Changing the Settings | Camera settings

Daylight Saving Time (Summer time) setting

1. Press the NEXT button or PREV button to select [SETUP] - [CONFIG] - [DST], then press the ENTER button.
2. Press the NEXT button or PREV button to select the following setting, then press the ENTER button.



ON: Sets the Daylight Saving Time (summer time).



OFF: Does not set the Daylight Saving Time (summer time).



BACK: Returns to the [DST] menu.

[54] How to use | Changing the Settings | Camera settings

Language setting

You can set the displayed language.

1. Press the NEXT button or PREV button to select [SETUP] - [CONFIG] - [LANG], then press the ENTER button.
2. Press the NEXT button or PREV button to select the following setting, then press the ENTER button.



EN: Sets English.



FR: Sets French.



BP: Sets Brazilian Portuguese.



TR: Sets Turkish.



BACK: Returns to the [LANG] menu.

[55] How to use | Changing the Settings | Camera settings

Switching NTSC/PAL

You can select the NTSC/PAL setting, depending on the TV system of the country or region where you use this camera.

1. Press the NEXT button or PREV button to select [SETUP] - [CONFIG] - [V.SYS], then press the ENTER button.
2. Press the NEXT button or PREV button to select the following setting, then press the ENTER button.



NTSC: Select this when the TV system is NTSC.



PAL: Select this when the TV system is PAL.



BACK: Returns to the [V.SYS] menu.

3. Press the NEXT button or PREV button, then press the ENTER button while [OK] is displayed on the display panel.

To cancel the NTSC/PAL setting, press the NEXT button or PREV button while [OK] is displayed to select [CANCL], then press the ENTER button.

Note

- When you change the NTSC/PAL setting, the camera will restart automatically.

[56] How to use | Changing the Settings | Camera settings

Version

Displays the software version of the camera.

1. Press the NEXT button or PREV button to select [SETUP] - [CONFIG] - [VER.], then press the ENTER button.

[57] How to use | Changing the Settings | Camera settings

Format

Formatting is the process of deleting all images in the memory card, and restoring the memory card to its initial state.

1. Press the NEXT button or PREV button to select [SETUP] - [CONFIG] - [FORMAT], then press the ENTER button.
2. Press the ENTER button to display [SURE?] after [OK] has been displayed, then press the ENTER button again.

Formatting starts and [DONE] appears when formatting finishes.

To cancel formatting, press the NEXT button or PREV button while [SURE?] or [OK] is displayed to select [CANCL], then press the ENTER button.

Note

- Save important images before formatting.
- Do not perform any of the following operations while formatting.

- Press a button.
- Eject the memory card.
- Connect/disconnect a cable.
- Insert/remove the battery pack.

[58] How to use | Changing the Settings | Camera settings

Resetting the settings

You can reset the settings to their defaults.

1. Press the NEXT button or PREV button to select [SETUP] - [CONFG] - [RESET], then press the ENTER button.
2. Press the ENTER button to display [SURE?] while [OK] is displayed, then press the ENTER button again.
 - The camera automatically restarts when resetting is complete.
 - To cancel resetting, press the NEXT button or PREV button while [SURE?] or [OK] is displayed to select [CANCL], then press the ENTER button.

[59] How to use | Viewing | Viewing images on a TV

Viewing images on a TV

Connect the camera to a TV which has an HDMI terminal using a micro HDMI cable (sold separately). Refer also to the instruction manuals of the TV.

1. Turn off both the camera and the TV.
2. Open the connector cover and connect the camera to the TV with the micro HDMI cable (sold separately).
3. Turn on the TV and set the input of the TV to [HDMI input].
4. Press the NEXT button or PREV button on the camera to turn on.
5. Press the NEXT button or PREV button to display [PLAY], then press the ENTER button.
6. Press the NEXT button or PREV button to display the desired image to view, then press the ENTER button.
 - Select the settings below.
 - [MP4]: MP4 movies
 - [PHOTO]: Still images
 - [4K30p]: XAVC S movie (FDR-X1000V only)
[4K30p] is displayed when NTSC is selected and [4K25p] is displayed when PAL is selected.

- [4K24p]: XAVC S movie (FDR-X1000V only)
[4K24p] is only displayed when NTSC is selected.
 - [HD]: XAVC S movie
- If you want to play back movie, select the item then press the ENTER button to start playing back.

7. Press the ENTER button.

Stop playback.

To control a content being played back

- Viewing the previous/next image: Press the PREV/NEXT button.
- Fast-rewind/fast-forward (movies only): Press and hold the PREV/NEXT button.
- Pause (movies only): Press the PREV and NEXT buttons simultaneously.
If you press and hold the PREV or NEXT button during pause, slow rewind or slow forward can be performed.
- Adjusting the volume (movies only): Press and hold the PREV and NEXT buttons simultaneously.
- Starting a slideshow (still images only): Press the PREV and NEXT buttons simultaneously.
- Ending playback: Press the ENTER button.

Notes on playing back on other devices

Movies recorded using this camera may not play back normally on devices other than this camera. Also, movies recorded on other devices may not play back properly on this camera.

[60] How to use | Viewing | Deleting images

Delete

Unwanted images in the memory card are deleted by using a smartphone installed with PlayMemories Mobile or the Live-View Remote.
Refer to the instruction manual on the website for how to operate PlayMemories Mobile or the Live-View Remote.

Note

- If you want to delete all images in the memory card, format the memory card in the camera.

[61] How to use | Create your movie | Highlight Movie Maker

Creating the highlight movie

This camera detects characteristic scenes from the movies shot with this camera and creates the movie composed of them (highlight movie) automatically.
You can copy highlight movies with your smartphone. By operating your smartphone, you can start the highlight movie creation and make the creation settings.

1. Open the PlayMemories Mobile of your smartphone and connect to this camera via Wi-Fi.
Refer to “Connecting to your smartphone” to connect this camera to your smartphone.

2. Select “Highlight Movie Maker” in “In-Camera Application Setting” from the “Settings” of the PlayMemories Mobile.

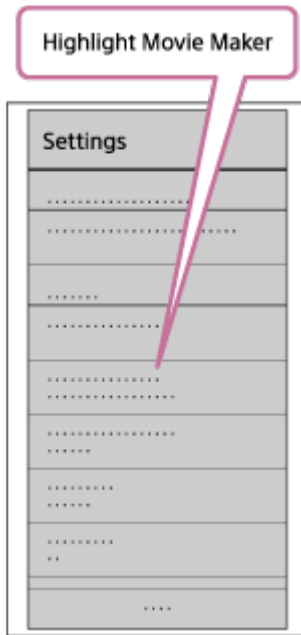

3. Press the  icon to select a content format that you want to add in a highlight movie.

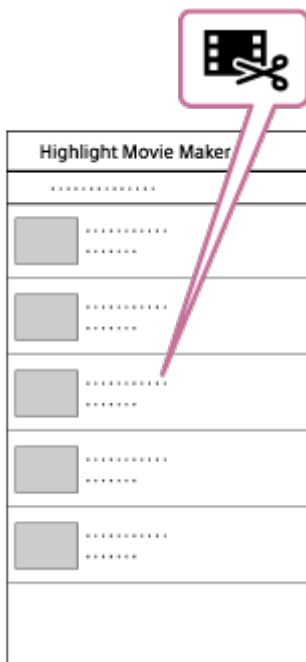

4. Select a movie that you want to add in a highlight movie from the date or the content list, then press the “Next” button.

The highlight movie creation starts.

- You cannot select MP4 and XAVC S contents at the same time.
- You can select up to 100 movies by date or file.
- If you disconnect the camera and your smartphone while creating the highlight movie, the camera continues to create movie.
- Press the REC button of this camera to finish creating the highlight movie.

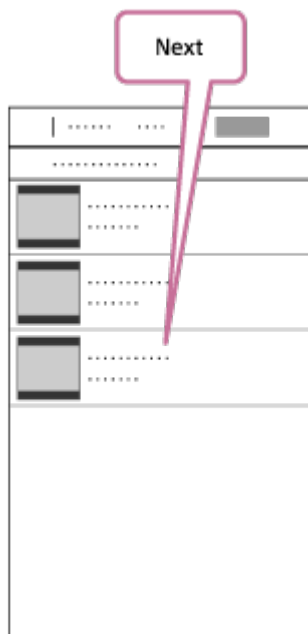

Hint

- Use the “Settings” menu to change the movie length, BGM and the audio mix.

5. After creating the highlight movie, you can copy it to your smartphone.

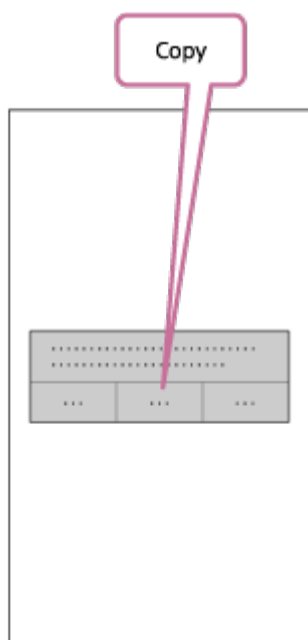

Hint

- Use the movie player application of a smartphone to play the copied highlight movie.

Note

- Update PlayMemories Mobile to the latest firmware version in advance.
- The created highlight movie's format is MP4.
- The following contents are not compatible with the highlight movie.
 - VGA
 - XAVC S 4K
 - XAVC S HD 24p

- High speed recording
- The operation methods and display screens for the application are subject to change without notice by future.
- See more details about “PlayMemories Mobile” from the following website.
(<http://www.sony.net/pmm/>)

[62] How to use | Create your movie | Highlight Movie Maker

Importing the BGM

By default, this camera includes eight songs that you can use as background music while playing back a highlight movie.

When you use the Action Cam Movie Creator connecting this camera with your computer, you can replace the background music of this camera with the music of your computer. Install the Action Cam Movie Creator to your computer in advance.

1. Press the NEXT button or PREV button to select [SETUP] - [CONFIG] - [BGM] - [DL], then press the ENTER button.
[USB] is displayed.
2. Connect the camera to the computer with the supplied micro USB cable.
The Music Transfer of Action Cam Movie Creator™ starts automatically.
3. Use the Music Transfer of Action Cam Movie Creator to import the BGM.

To preview the BGM

Refer to the following website for how to preview the pre-installed background music in this camera.

http://guide.d-imaging.sony.co.jp/mt_bgm/index.html

To delete all BGM

Select [SETUP] - [CONFIG] - [BGM] - [FORMT] - [OK] - [SURE?], then press the ENTER button.
[DONE] appears when formatting finishes.

Hint

- If the camera and the Action Cam Movie Creator cannot be connected, format the BGM by selecting [FORMT] in [BGM].

Note

- This function is not available in some countries/regions.

[63] How to use | Create your movie | Highlight Movie Maker

Mount

Register the place of installation to the camera in advance.

If you start shooting after registering the place of installation, the camera will detect every highlighted scene allowing you to make an appealing highlight movie with the Highlight Movie Maker.

1. Press the NEXT button or PREV button to select [SETUP] - [CONFIG] - [MOUNT], then press the ENTER button.
2. Press the NEXT button or PREV button to select the following setting, then press the ENTER button.



BODY: Select this function when the camera is attached to the person shooting the movie.

- Mount example: head mount, chest mount, backpack mount, wrist mount, monopod



OTHER: Select this function when the camera is attached to a board, bicycle, etc.

- Mount example: roll bar mount, handle bar mount, surfboard mount, suction cup mount



BACK: Returns to the [MOUNT] menu.

[64] How to use | Stream real-time movie to a movie streaming site | Live Streaming with your camera (Real time movie streaming)

Live Streaming

You can deliver movies in real-time via video sharing websites such as USTREAM by using a Wi-Fi router or smartphone that can tether the camera. You can also send messages to your registered SNS to announce that you have started Live Streaming of video*.

*Registration to a video streaming site or SNS is required.

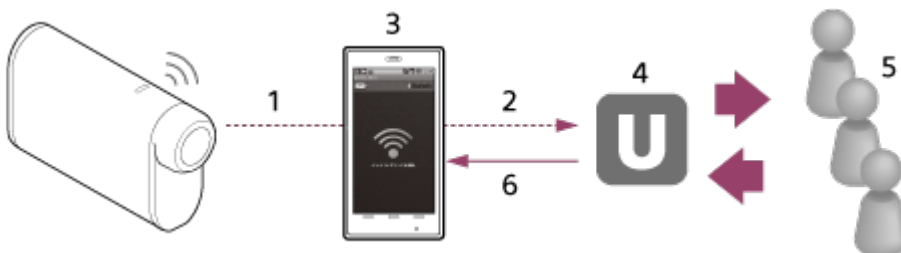

1. Wi-Fi
2. 3G/LTE
3. Tethering mode
4. USTREAM

5. Viewers
6. Comments from viewers

The following settings must be configured for live streaming.

Set the following distribution settings in the live streaming settings of the camera:

- User registration to USTREAM
- A smartphone (capable of tethering) or a Wi-Fi network environment

* For more information about smartphone tethering settings or Wi-Fi network settings, refer to the operating instructions supplied with the smartphone or network service. For further details about the network environment, contact your network service provider.

Live Streaming feature is dependent upon the Third Party Internet Provider's service and terms in your region. The feature may not be available due to your region's broadband and internet service restriction.

[65] How to use | Stream real-time movie to a movie streaming site | Live Streaming with your camera (Real time movie streaming)

Preparing for Live Streaming

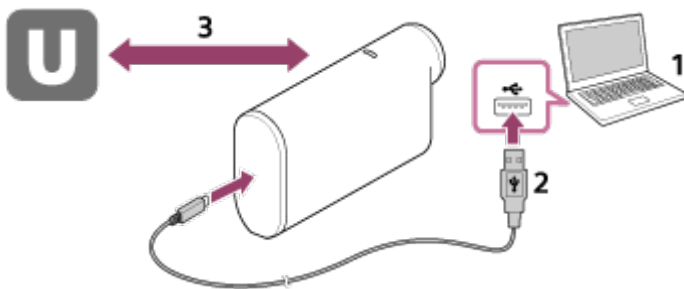

1. Before you start live streaming, get streaming site account and install the computer-exclusive application, "Action Cam Movie Creator."
Download "Action Cam Movie Creator" from the following website.
<http://www.sony.net/acmc/>
2. Connect this camera to your computer with supplied micro USB cable.
3. Configure the network settings, register an account at a video distribution site and configure the SNS settings on "Camera Settings for Live Streaming" of the Action Cam Movie Creator's camera settings.
You can set "Camera Settings for Live Streaming."
Refer to the following website for how to operate the Action Cam Movie Creator.
<http://www.sony.net/guide/nst/>

Camera settings for the live streaming

- Network settings
You can set the Wi-Fi network to which your camera connects to.
 - Network SSID, password, security mode
- Streaming settings
You can set the streaming method and information of videos.

- Streaming site, channel, image quality and the saving settings of the streaming site
- Title and description of streaming video
- SNS settings
By configuring this setting, you can post a comment through social network services when starting streaming video.
 - Connection settings for network services
 - Comments you post

About USTREAM

USTREAM is a video sharing site through which you can stream and view videos with the Live Streaming function of this camera. For details of USTREAM, see the following site.
<http://www.ustream.tv/>

Note

- Your personal information (information required when logging in to the SNS) is set in this camera. If you dispose or give away the camera, execute [SETUP] - [CONFIG] - [RESET] and delete the settings.

[66] How to use | Stream real-time movie to a movie streaming site | Live Streaming with your camera (Real time movie streaming)

Performing Live Streaming

You can start Live Streaming after the preparation is complete. When Live Streaming for the first time, it is recommended that you rehearse streaming in a prepared environment after setting up with a computer in advance.

1. Press the NEXT button or PREV button to display [LIVE].
2. Press the REC button to start streaming.
The REC lamp of the top of the camera lights up in blue.

Display during Live Streaming

PREP: Preparing to connect to the video streaming site
ONAIR: Starts streaming
00020: Displays the number of viewers

Note

- There may be time lag of 10 - 20 seconds between the start of Live Streaming on your camera and video streaming on the video streaming site.
- You can record movies that are being live distributed in the memory card of this camera. When the memory card is already inserted, movies are recorded at the same time as the distribution*.
- When the capacity of the memory card is full, only the movie recording will stop without stopping the distribution. Only movie distributions will be performed when no memory card is inserted.

* Simultaneously recorded movies are processed on MP4/HQ mode.

REC lamp indicator during Live Streaming

If you select Live Streaming mode, you can see the streaming status for Live Streaming with the REC lamp on the camera.





FDR-X1000V

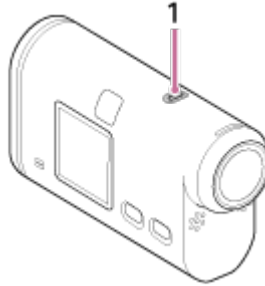

HDR-AS200V



1: REC/LIVE lamp

-  OFF: Before distribution
-  Lights up in blue: Distributing
-  Blinks slowly in blue (Approx. once per second): Distributing (There is an audience)
-  Blinks fast in red (Approx. three times per second): Distribution error

To stop the live distribution

Press the REC button again.

[67] How to use | Stream real-time movie to a movie streaming site | Live Streaming with your camera (Real time movie streaming)

Restrictions

Notification of the restriction when using live streaming.

Restrictions for USTREAM

- There are some restrictions for video streaming on USTREAM. For details, see the USTREAM site.

Restrictions on GPS and Wi-Fi functions during Live Streaming

- The GPS function is disabled automatically during Live Streaming.
Also, you cannot monitor images using a smartphone or the Live-View Remote during Live Streaming.

Network connection

- Use a smartphone capable of tethering or Wi-Fi router for Live Streaming. However, proper operation with all smartphones or Wi-Fi routers is not guaranteed. Public wireless LANs cannot be used as connections for Live Streaming.

Simultaneous Live Streaming with multiple cameras

- You cannot live stream videos simultaneously using the same account on more than 1 camera. You need to connect using another account.

Effects due to wireless communication conditions

- When connected using the tethering function of a smartphone or via a Wi-Fi router, images and sounds may be interrupted, or the communication may be cut off due to wireless communication conditions.

Connection for Live Streaming

- The communication time you can use for Live Streaming is limited according to the contract of your smartphone or Wi-Fi router. Confirm it in advance.

Continuous streaming time

- Continuous Live Streaming using this camera is limited to about 13 hours.

Restrictions of network connections

- In some countries, you cannot connect to Live Streaming sites. Use this function in accordance with the laws of that country.

[68] How to use | Using the camera connected to other devices via Wi-Fi | Connecting to your smartphone

Preparation for connecting to your smartphone

Installing the application on your smartphone

Install the PlayMemories Mobile™ on your smartphone. Update PlayMemories Mobile to the latest version if you have already installed it on your smartphone.

For the latest information details about the functions of PlayMemories Mobile, refer to the website below.
<http://www.sony.net/pmm/>

Search for PlayMemories Mobile on Google Play, then install it.

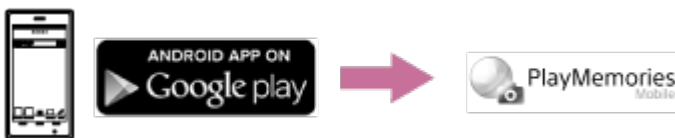

- When using One-touch functions (NFC), Android 4.0 or later is required.

Search for PlayMemories Mobile on App Store, then install it.



- When using iOS, One-touch functions (NFC) are not available.

If the password is lost

1. Connect the camera to a computer with the micro USB cable (supplied).
2. Turn on the camera.

3. Display [Computer] - [PMHOME] - [INFO] - [WIFI_INF.TXT] on your computer, then check the user ID and password.

Note

- Google play may not be supported depending on country or region. In this case, search for “PlayMemories Mobile” on the internet then install it.
- An NFC-enabled smartphone or tablet is required for using One-touch functions (NFC).
- The Wi-Fi function described here is not guaranteed to work with all smartphones and tablets.

[69] How to use | Using the camera connected to other devices via Wi-Fi | Connecting to your smartphone

Sample smartphone screen display

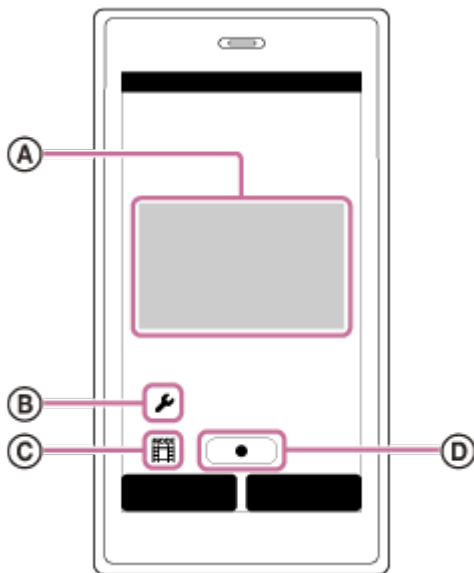

Ⓐ: Features of the Wi-Fi remote control function

- To check the field of view before and while recording
- To monitor images while recording

Ⓑ: Various settings

Ⓒ: Shooting mode settings

- 🎬 [Movie]
- 📷 [Photo]
- 🔄 [Interval photo recording]
- 🔄 [Loop recording]



Ⓓ: Start/stop recording

Note

- When the airplane mode is set to [ON], the Wi-Fi function is not available.
- Depending on local electrical interference or the smartphone’s capabilities, the live view images may not be displayed smoothly.

Using One-touch Functions to Connect to an NFC-enabled Android Smartphone

Perform preparation for connecting to your smartphone before connecting.

1. Select [SETUP] - [CONFIG] - [Wi-Fi] - [ON] on the camera.
2. Confirm that the camera is in the shooting mode.
 - LOOP: Loop recording mode
 - MOVIE: Movie mode
 - PHOTO: Photo mode
 - INTVL: Interval photo recording mode
3. Select [Settings] on the smartphone, then select [More...] and check that [NFC] is enabled.
4. Touch the smartphone to the camera.
 - Cancel sleep and the screen lock of the smartphone beforehand.
 - Continue touching without moving until PlayMemories Mobile starts (1-2 seconds).
 - Touch the  (N Mark) of the smartphone to the  (N Mark) of the camera. If there is no (N Mark) on the smartphone, refer to the instruction manual of the smartphone for the touch area.
 - If the camera and the smartphone cannot be connected by NFC, see "[Connecting to a smartphone without using NFC](#)" and connect them.

About NFC

NFC is a technology for short-range wireless communication between various devices, such as a mobile phones and IC tags. Data communication is achieved simply by touching devices together at a specific point. NFC (Near Field Communication) is an international standard of the short-range wireless communication technology.

Note

- When the airplane mode is set to [ON], the Wi-Fi function is not available.
- You cannot connect a smartphone to multiple cameras at the same time.
- Depending on local electrical interference or the smartphone's capabilities, the live view images may not be displayed smoothly.

Connecting to a smartphone without using NFC

Perform preparation for connecting to your smartphone before connecting.

1. Select [SETUP] - [CONFIG] - [Wi-Fi] - [ON] on the camera.
2. Confirm that the camera is in the shooting mode.
 - LOOP: Loop recording mode
 - MOVIE: Movie mode
 - PHOTO: Photo mode
 - INTVL: Interval photo recording mode
3. Connect your smartphone.

Android

1. Start PlayMemories Mobile on the smartphone.

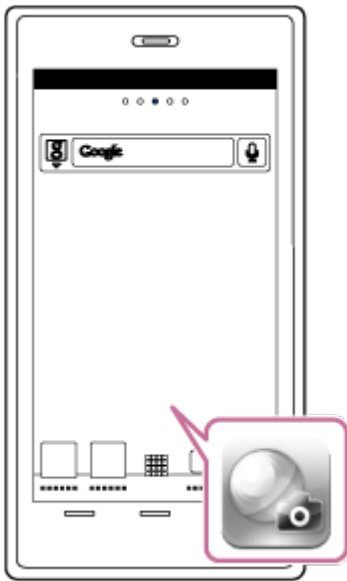

2. Select the SSID that is printed on the sticker attached to Startup Guide.



3. Input the password on the same sticker (First time only).

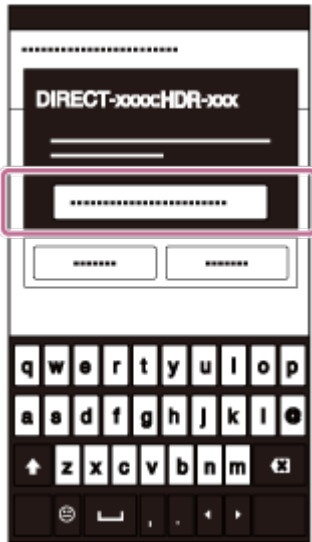

iPhone/iPad

1. Open [Settings] and select [Wi-Fi] on the smartphone. Select the SSID that is printed on the sticker attached to Startup Guide.

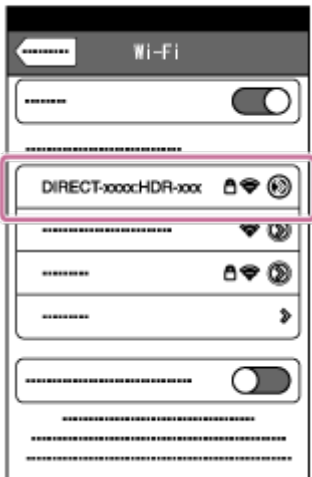

2. Input the password on the same sticker (First time only).

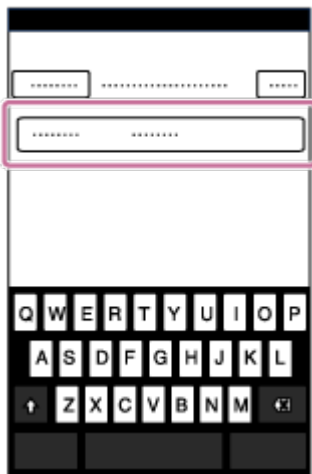

3. Confirm that the SSID of the camera is displayed on the smartphone.

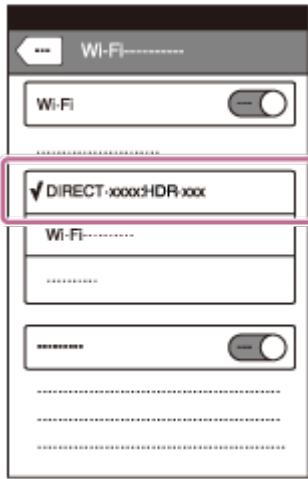

4. Return to the Home screen, then start PlayMemories Mobile.

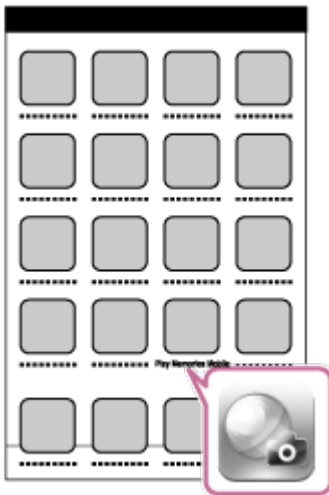

Note

- When the airplane mode is set to [ON], the Wi-Fi function is not available.
- You cannot connect a smartphone to multiple cameras at the same time.
- Depending on local electrical interference or the smartphone's capabilities, the live view images may not be displayed smoothly.

[72] How to use | Using the camera connected to other devices via Wi-Fi | Connecting to the Live-View Remote

Connecting a single camera to Live-View Remote (Single connection)

1. Turn on the Live-View Remote.

For details, refer to “Connecting this unit to a single camera via Wi-Fi” in the Help Guide of the Live-View Remote (RM-LVR2).

http://rd1.sony.net/help/cam/1530/h_zz/

2. Set the connection mode of the camera.

Press the NEXT button or PREV button to select [SETUP] - [CONFIG] - [Wi-Fi] - [ON], then press the ENTER button.

3. Select the SSID that is printed on the sticker attached to Startup Guide.
4. When this camera beeps and [ACPT?] is displayed on the display panel of this camera, press the ENTER button of this camera.

Note

- When [BEEP] is set to [OFF], the connection beep does not sound.

[73] How to use | Using the camera connected to other devices via Wi-Fi | Connecting to the Live-View Remote

Connecting multiple cameras to Live-View Remote (Multi connection)

1. Turn on the Live-View Remote.

For details, refer to “Connecting this unit to multiple cameras via Wi-Fi” in the Help Guide of the Live-View Remote (RM-LVR2).

http://rd1.sony.net/help/cam/1530/h_zz/

2. Set the camera.

- When you connect the camera to Live-View Remote for the first time
Press the NEXT button or PREV button to select [SETUP] - [CONFIG] - [Wi-Fi] - [MULTI] - [NEW], then press the ENTER button.
When this camera beeps and [AWAIT] is displayed on the display panel of this camera, register this camera using the Live-View Remote.
[DONE] appears on the display panel of this camera when connecting finishes.
- When you connect the camera to Live-View Remote since second time
Press the NEXT button or PREV button to select [SETUP] - [CONFIG] - [Wi-Fi] - [MULTI] - [CRRNT], then press the ENTER button.

3. If you will continue to connect multiple cameras, repeat from step 2.

Note

- When [BEEP] is set to [OFF], the connection beep does not sound.

[74] How to use | Using the camera connected to other devices via Wi-Fi | Connecting to Handycam

Connecting a single camera to Handycam (Single connection)

connection)

You can operate this camera using a Handycam that supports the multi camera control function.

1. Turn on the Handycam.

For details, refer to “Connecting this product to one camera with Multi Camera Control (Single Connection)” in the Help Guide of the Handycam.

Example: Help Guide of FDR-AX30/AXP35

http://rd1.sony.net/help/cam/1510/h_zz/

2. Set the connection mode of the camera.

Press the NEXT button or PREV button to select [SETUP] - [CONFIG] - [Wi-Fi] - [ON], then press the ENTER button.

3. Select the SSID that is printed on the sticker attached to Start Guide.

4. When this camera beeps and [ACPT?] is displayed on the display panel of this camera, press the ENTER button of this camera.

Note

- When [BEEP] is set to [OFF], the connection beep does not sound.

[75] How to use | Using the camera connected to other devices via Wi-Fi | Connecting to Handycam

Connecting multiple cameras to Handycam (Multi connection)

You can operate this camera using a Handycam that supports the multi camera control function.

1. Turn on the Handycam.

For details, refer to “Connecting this product to more than one camera with Multi Camera Control (Multi Connection)” in the Help Guide of the Handycam.

Example: Help Guide of FDR-AX30/AXP35

http://rd1.sony.net/help/cam/1510/h_zz/

2. Set the connection mode of the camera.

- When you connect the camera to Handycam for the first time

Press the NEXT button or PREV button to select [SETUP] - [CONFIG] - [Wi-Fi] - [MULTI] - [NEW], then press the ENTER button.

When this camera beeps and [AWAIT] is displayed on the display panel of this camera, register this camera using the Handycam.

[DONE] appears on the display panel of this camera when connecting finishes.

- When you connect the camera to Handycam since second time

Press the NEXT button or PREV button to select [SETUP] - [CONFIG] - [Wi-Fi] - [MULTI] -

[CRRNT], then press the ENTER button.

3. If you will continue to connect multiple cameras, repeat from step 2.

Note

- When [BEEP] is set to [OFF], the connection beep does not sound.

[76] How to use | Editing images imported to your computer | Using the Action Cam Movie Creator

Useful functions of Action Cam Movie Creator

Action Cam Movie Creator™ allows you to import movies to your computer to use them in various ways.

Visit the following URL to install the software.

<http://www.sony.net/acmc/>

Action Cam Movie Creator, which can edit movies and PlayMemories Home, which can manage movies and photos, will be installed.

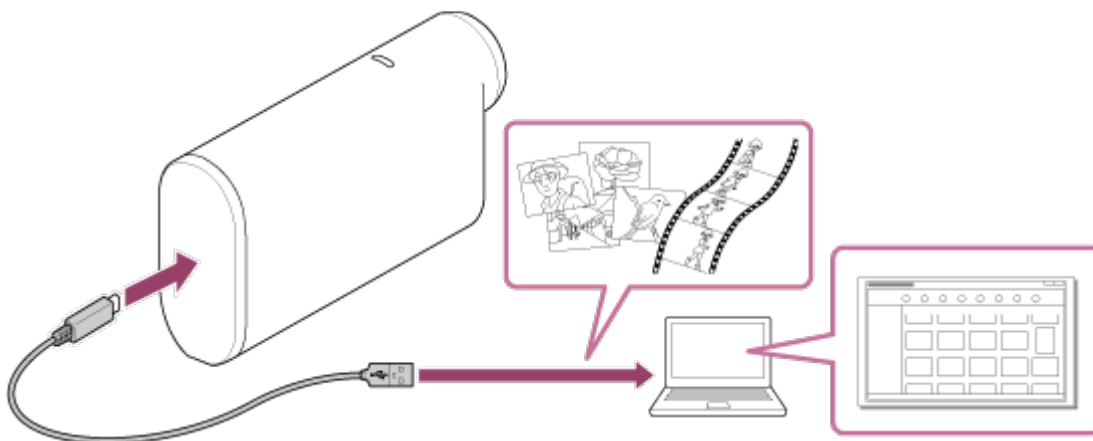

Useful functions of Action Cam Movie Creator

- Editing movies and displaying them with tracking information and movement speed.

Useful functions of PlayMemories Home

- Importing and playing back movies and still images

Note

- When you import movies to your computer, use PlayMemories Home. If you import using another method, your GPS information may be lost.
- Use the micro USB cable (supplied) when connecting the camera to your computer.

[77] How to use | Editing images imported to your computer | Using the Action Cam Movie Creator

Installing Action Cam Movie Creator on your computer

Install Action Cam Movie Creator™ on your computer. Follow the steps below.

1. Turn on the computer.
 - Log on as an Administrator.
 - Close all applications running on the computer before installing the software.
2. Visit the following URL with the Internet browser of the computer and install Action Cam Movie Creator.
 - <http://www.sony.net/acmc/>
 - When installation is complete, Action Cam Movie Creator starts up.
3. Connect the camera to the computer with the supplied micro USB cable.
 - New function may be added to Action Cam Movie Creator. Even if Action Cam Movie Creator is already installed on your computer, connect the camera to your computer.

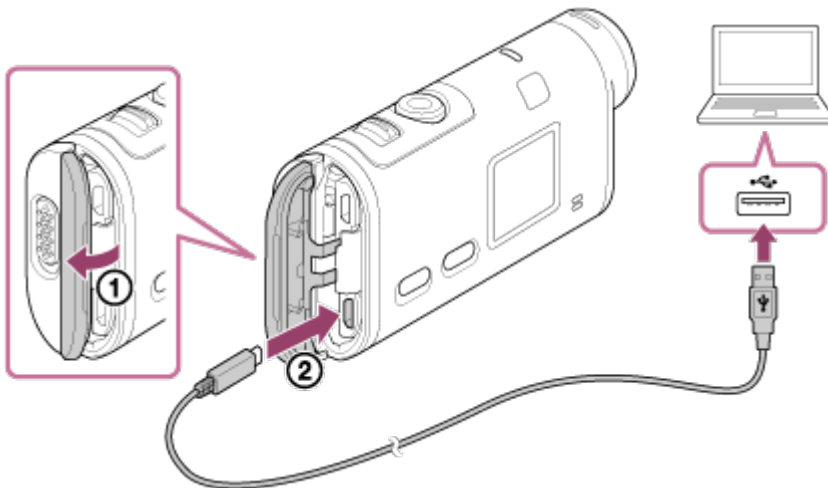

FDR-X1000V

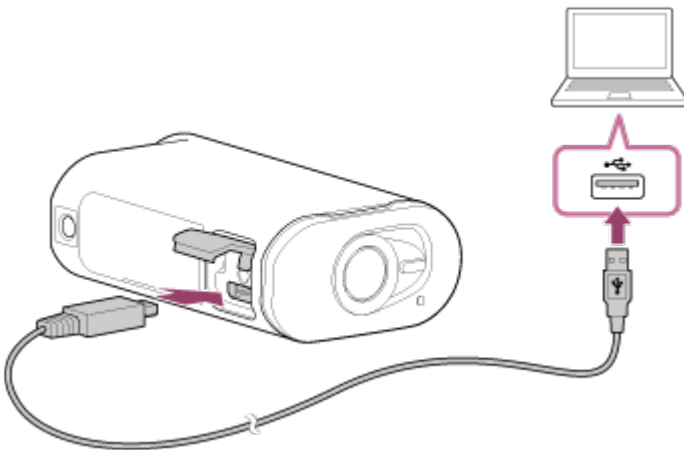

HDR-AS200V



Note

- Do not disconnect the micro USB cable (supplied) from the camera while the computer screen indicates that the camera is being operated or accessed. Doing so may cause data corruption.
- To disconnect the computer from the camera, click  on the task tray then click  (Icon to remove). If you are using Windows Vista, click  on the task tray.

[78] How to use | Others | Recordable time

Estimated duration of recording and playback for supplied battery pack

Recording time

Approximate time available when you use a fully charged battery pack.

FDR-X1000V

- Image quality: 4K30P
Continuous recording time: 50 minutes (50 minutes)
Typical recording time: 30 minutes (30 minutes)
- Image quality: HQ
Continuous recording time: 115 minutes (125 minutes)
Typical recording time: 70 minutes (75 minutes)

HDR-AS200V

- Image quality: HQ
Continuous recording time: 115 minutes (125 minutes)
Typical recording time: 75 minutes (80 minutes)
 - The recording time measured when using one fully charged battery pack
 - The recording time may be shorter, depending on the recording conditions.
 - () indicates the recording time when the Wi-Fi remote control function is set to [OFF].
 - The recording time may be longer when you set the Wi-Fi or GPS setting off.

Playing time

Approximate time available when you use a fully charged battery pack.

Approximate time when images are played back on a TV connected with a micro HDMI cable (sold separately).

FDR-X1000V

- Image quality: 4K30P
Playing time: 100 minutes
- Image quality: HQ
Playing time: 215 minutes

HDR-AS200V

- Image quality: HQ
Playing time: 205 minutes
-

Estimated recording time of movies

XAVC S 4K Average recording time (FDR-X1000V)

Recorded image: 100 Mbps

When using 64GB memory card: Approx. 75 minutes

Recorded image: 60 Mbps

When using 64GB memory card: Approx. 125 minutes

XAVC S HD Average recording time (FDR-X1000V)

Recorded image: 100 Mbps

When using 64GB memory card: Approx. 75 minutes

Recorded image: 60 Mbps

When using 64GB memory card: Approx. 125 minutes

Recorded image: 50 Mbps

When using 64GB memory card: Approx. 155 minutes

XAVC S HD Average recording time (HDR-AS200V)

Recorded image: 50 Mbps

When using 64GB memory card: Approx. 155 minutes

MP4 Average recording time

Image quality: PS

When using 8GB memory card: 35 minutes

When using 16GB memory card: 75 minutes

When using 32GB memory card: 155 minutes

When using 64GB memory card: 320 minutes

Image quality: HS120/HS100/HS240/HS200

When using 8GB memory card: 35 minutes

When using 16GB memory card: 75 minutes

When using 32GB memory card: 155 minutes

When using 64GB memory card: 320 minutes

Image quality: HQ

When using 8GB memory card: 60 minutes

When using 16GB memory card: 125 minutes

When using 32GB memory card: 250 minutes

When using 64GB memory card: 505 minutes

- When using a Sony memory card.

-
- The recordable time may vary depending on the recording conditions, subjects, and the image quality setting.
 - Continuous movie shooting time is approximately 13 hours.

[80] How to use | Others | Recordable time

Estimated number of recordable still images

Number of pixels: 2M (Interval photo recording) (16:9)

When using 8GB memory card: 6800 images

When using 16GB memory card: 13500 images

When using 32GB memory card: 27500 images

When using 64GB memory card: 40000 images

Number of pixels: 8.8M (Still images)

When using 8GB memory card: 2150 images

When using 16GB memory card: 4350 images

When using 32GB memory card: 8700 images

When using 64GB memory card: 17000 images

[81] How to use | Others | Battery pack

On charging the battery pack

- Charge the battery pack before using the camera for the first time.
- We recommend charging the battery pack in an ambient temperature of between 10°C to 30°C (50°F to 86°F) until the REC/access/CHG (Charge) lamp turns off. The battery pack may not be effectively charged in temperatures outside this range.
- The REC/access/CHG (Charge) lamp may blink in the following situation:
 - Battery pack is not attached correctly.
 - Battery pack is damaged.
- When the battery pack temperature is low, detach the battery pack and place it in warm surroundings.
- When the battery pack temperature is high, detach the battery pack and place it in cool surroundings.

[82] How to use | Others | Battery pack

Effective use of the battery pack

- Battery pack performance decreases in low temperature surroundings (less than 10°C (50°F)). So in cold places, the operational time of the battery pack is shorter. We recommend the following to ensure longer battery pack use: Put the battery pack in a pocket close to your body to warm it up, and insert it in the camera immediately before you start shooting.

- The battery pack will run out quickly if you use the playback, fast-forward, and fast-rewind frequently.
 - Turn off the camera every time you do not shoot or playback on the camera. Battery pack is wearing out when the shooting is in standby.
 - We recommend having spare battery packs handy for two times or three times the expected shooting time, and making trial shots before taking the actual shots.
 - You may not be able to turn on the camera or the battery pack may not be effectively charged if the terminal section of the battery pack is dirty. In this case, wipe any dust with a soft cloth lightly to clean the battery pack.
 - Do not expose the battery pack to water. The battery pack is not water-resistant.
-

[83] How to use | Others | Battery pack

About the remaining battery charge

If the battery pack runs out so fast although the remaining charge indicator is high, fully charge the battery pack again. Remaining charge indicator will be displayed correctly. Note that it may not be displayed correctly in the following situations:

- Using the camera for a long time in high temperature
 - Leaving the camera with fully charged battery pack
 - Using a heavily used battery pack
-

[84] How to use | Others | Battery pack

How to store the battery pack

- To maintain the battery pack's function, fully charge the battery pack and then fully discharge it on the camera at least once a year while storing. Remove the the battery pack from the camera and store it in a cool, dry place.
 - To prevent staining the terminal, short-circuiting, etc., be sure to use a plastic bag to keep away from metal materials when carrying or storing.
-

[85] How to use | Others | Battery pack

On battery pack life

- The battery pack life is limited. Battery capacity decreases over time and through repeated use. If decreased usage time between charges becomes significant, it is probably time to replace it with a new one.
 - The battery pack life varies according to how a battery pack is used.
-

[86] How to use | Others | Using the camera abroad

On TV color systems

To view images shot by the camera on a TV, you need a TV (or monitor) with an HDMI jack and a micro HDMI cable (sold separately).

Before shooting, be sure to set [V.SYS] to the TV system of the country and region where you will view recordings.

[87] How to use | Others | Using the camera abroad

Countries and regions where you can view images when [V.SYS] is set to [NTSC]

Barbados, Bermuda, Bolivia, Canada, Chile, Columbia, Costa Rica, Cuba, Dominica, Ecuador, El Salvador, Guam, Guatemala, Guyana, Haiti, Honduras, Japan, Mexico, Micronesia, Myanmar, Nicaragua, Panama, Peru, Philippines, Puerto Rico, Republic of Korea, Saint Lucia, Samoa, Suriname, Taiwan, Trinidad and Tobago, United States of America, Venezuela etc.

[88] How to use | Others | Using the camera abroad

Countries and regions where you can view images when [V.SYS] is set to [PAL]

Australia, Austria, Argentina, Belgium, Bulgaria, Brazil, China, Croatia, Czech Republic, Denmark, Finland, France, French Guiana, Germany, Greece, Hong Kong, Hungary, Indonesia, Iran, Iraq, Italy, Kuwait, Malaysia, Monaco, Netherlands, New Zealand, Norway, Paraguay, Poland, Portugal, Romania, Russia, Singapore, Slovakia, Spain, Sweden, Switzerland, Thailand, Turkey, Ukraine, United Kingdom, Uruguay, Vietnam etc.

[89] How to use | Others | Using the camera abroad

The list of time differences for world capitals

Time differences with the standard times of world cities (as of 2015).

Lisbon/London

GMT

Berlin/Paris

+01:00

Helsinki/Cairo/Istanbul

+02:00

Moscow/Nairobi

+03:00

Tehran

+03:30

Abu Dhabi/Baku

+04:00

Kabul

+04:30

Karachi/Islamabad

+05:00

Kolkata/New Delhi

+05:30

Almaty/Dhaka

+06:00

Yangon

+06:30

Bangkok/Jakarta

+07:00

Hong Kong/Singapore/Beijing

+08:00

Tokyo/Seoul

+09:00

Adelaide/Darwin

+09:30

Melbourne/Sydney

+10:00

New Caledonia

+11:00

Fiji/Wellington

+12:00

Midway

-11:00

Hawaii

-10:00

Alaska

-09:00

San Francisco/Tijuana

-08:00

Denver/Arizona

-07:00

Chicago/Mexico City

-06:00

New York/Bogota

-05:00

Santiago

-04:00

St.John's

-03:30

Brasilia/Montevideo

-03:00

Fernando de Noronha

-02:00

Azores, Cape Verde Is.

-01:00

[90] [How to use](#) | [Others](#) | [Precautions](#)

Do not use/store the camera in the following places

- In an extremely hot, cold or humid place
In places such as in a car parked under the sun, the camera body may become deformed and this may cause a malfunction.
- Under direct sunlight or near a heater are not suitable places for storage.
The camera body may become discolored or deformed, and this may cause a malfunction.
- In a location subject to strong vibration
- Near strong magnetic fields
- In sandy or dusty places
Be careful not to let sand or dust get into the camera. This may cause the camera to malfunction, and

in some cases may be irreparable.

[91] [How to use](#) | [Others](#) | [Precautions](#)

On carrying

Do not sit down in a chair or other place with the camera in the back pocket of your trousers or skirt, as this may cause malfunction or damage the camera.

[92] [How to use](#) | [Others](#) | [Precautions](#)

Care and storage of the lens

- Wipe the surface of the lens clean with a soft cloth in the following instances:
 - When there are fingerprints on the lens surface.
 - In hot or humid locations
 - When the lens is exposed to salty air such as at the seaside.
 - Store in a well-ventilated location subject to little dirt or dust.
 - To prevent mold, periodically clean the lens as described above.
-

[93] [How to use](#) | [Others](#) | [Precautions](#)

On cleaning

Clean the camera surface with a soft cloth slightly moistened with water, then wipe the surface with a dry cloth. Do not use any of the following as they may damage the finish or the casing.

- Chemical products such as thinner, benzine, alcohol, disposable cloths, insect repellent, sunscreen or insecticide, etc.
 - Do not touch the camera with any of the above on your hand.
 - Do not leave the camera in contact with rubber or vinyl for a long time.
-

[94] [How to use](#) | [Others](#) | [Precautions](#)

On operating temperatures

The camera is designed for use in temperatures between -10°C and $+40^{\circ}\text{C}$ (14°F and 104°F). Shooting in extremely cold or hot places that exceed this range is not recommended.

On moisture condensation

If the camera is brought directly from a cold to a warm location, moisture may condense inside or outside the camera. This moisture condensation may cause a malfunction of the camera.

If moisture condensation occurs

Turn off the camera and wait about 1 hour for the moisture to evaporate.

Note on moisture condensation

Moisture may condense when you bring the camera from a cold place into a warm place (or vice versa) or when you use the camera in a humid place as shown below.

- When you bring the camera from a ski slope into a warm place.
- When you bring the camera from an air conditioned car or room into a hot place outside.
- When you use the camera after a squall or a shower.
- When you use the camera in a hot and humid place.

How to avoid moisture condensation

When you bring the camera from a cold place into a warm place, put the camera in a plastic bag and seal it tightly. Remove the bag when the air temperature inside the plastic bag has reached the ambient temperature (after about 1 hour).

Notes on optional accessories

Genuine Sony accessories may not be available in some countries/regions.

Note on disposal/transfer of the memory card

Even if you delete data in the memory card or format the memory card on the camera or a computer, you may not delete data from the memory card completely. When you give the memory card to somebody, it is recommended that you delete data completely using data deletion software on a computer. Also, when you dispose of the memory card, it is recommended that you destroy the actual body of the memory card.

On GPS

- As the positions of GPS satellites vary constantly, it may take longer to determine the location or the receiver may not be able to determine the location at all, depending on the location and time you use

the camera.

- GPS is a system that determines your position by receiving signals from satellites. Avoid using the GPS feature on your camera in places where radio signals are blocked or reflected, such as a shadowy place surrounded by buildings or trees, etc. Use the camera in open sky environments.
- You may not be able to record location information at locations or in situations where radio signals from the GPS satellites do not reach the camera as follows.
 - In tunnels, indoors or under the shade of buildings
 - Between tall buildings or at narrow streets surrounded by buildings
 - In underground locations, locations surrounded by dense trees, under an elevated bridge, or in locations where magnetic fields are generated, such as near high voltage cables.
 - Near devices that generate radio signals of the same frequency band as the camera: near 1.5 GHz band mobile telephones, etc.
- If you take images with the GPS log set to [ON], and upload those images to the Internet, the shooting location may be available to third parties. To prevent this, set GPS log to [OFF] before shooting.

[99] [How to use](#) | [Others](#) | [Precautions](#)

On GPS errors

- If you move to another location right after turning the camera on, it may take a longer time for the camera to start triangulating, compared to when you stay in the same place.
- Error caused by the position of GPS satellites
The camera automatically triangulates your current location when the camera receives radio signals from 3 or more GPS satellites. The triangulating error allowed by the GPS satellites is about 10 m (33 feet). Depending on the environment of the location, the triangulating error can be greater. In this case, your actual location may not match the location on the map based on the GPS information. Meanwhile, the GPS satellites are controlled by the United States Department of Defense, and the degree of accuracy may be changed intentionally.
- Error during the triangulating process
The camera acquires location information periodically during triangulating. There is a slight time lag between when the location information is acquired and when the location information is recorded on an image, therefore, the actual recording location may not match the exact location on the map based on the GPS information.

[100] [How to use](#) | [Others](#) | [Precautions](#)

On GPS use restriction

Use GPS in accordance with the situation and regulations of the countries/regions where you use the camera.

[101] [How to use](#) | [Others](#) | [Specifications](#)

Specifications

FDR-X1000V

[System]

Video signal:

- UHDTV
- HDTV
- NTSC color, EIA standards
- PAL color, CCIR standards

Image device:

- 1/2.3 type (7.81 mm) Exmor R CMOS sensor
- Pixel Gross: Approx. 12.8 megapixels
- Effective picture resolution (movie): Approx. 8.8 megapixels (16:9) (SteadyShot is set to [OFF])
- Effective picture resolution (still): Approx. 8.79 megapixels (16:9)
- Still image max effective: Approx. 8.79 megapixels (16:9)
- Interval photo recording mode: Approx. 2.07 megapixels (16:9)

Lens:

- ZEISS Tessar Lens
- Aperture: F2.8
- Focal distance: $f = 2.8$ mm
- Focal length (35 mm equivalent) (Movie mode): $f = 17.1$ mm (16:9) (Movie, SteadyShot is set to [OFF])
- FOV: 170° (SteadyShot is set to [OFF])

Camera:

- Exposure control: Automatic exposure
- Minimum illumination: 6 lx (lux)
- Image stabilization: Electronic SteadyShot image stabilization
- Minimum shooting distance: Approx. 50 cm (19 3/4 in.)

File format:

- Movies: MP4: MPEG-4 AVC/H.264, XAVC S: MPEG-4 AVC/H.264
- Audio: MPEG-4 AAC-LC 2ch (When recording MP4 movies), LPCM 2ch (When recording XAVC S movies)
- Still images: JPEG (DCF Ver. 2.0, Exif Ver. 2.3, MPF Baseline) compliant

Recording media:

- When recording MP4 movies:
Memory Stick Micro (Mark2) media
microSD/SDHC/SDXC card (Class4 or faster)
- When recording XAVC S (50Mbps/60Mbps) movies:
microSDXC card (Class10 or faster)
- When recording XAVC S (100Mbps) movies:
microSDXC card (UHS-I U3 or faster)

[Input and Output connectors]

- Multi/Micro USB Terminal*: micro-B/USB2.0 Hi-Speed
(Supports Micro USB compatible devices.)

*USB connection is only for output. (For customers in some countries/regions)

[Power]

Power requirements:

- Rechargeable battery pack: 3.6 V (NP-BX1 (supplied))
- Multi/Micro USB Terminal: 5.0 V

Charging method:

- USB charging: DC 5.0 V, 500 mA/800 mA

Charging time:

- Via a computer
NP-BX1 (supplied): Approx. 4 h 5 min.
- Via the AC-UD10 (sold separately)
NP-BX1 (supplied): Approx. 2 h 55 min.

Power supply method:

- USB power supply (1.5 A or more is recommended)

Power consumption:

- 2.0 W (when the image quality is "MP4 HQ 1920 × 1080/30p")

Battery:

- Rechargeable battery pack: NP-BX1 (supplied)
Maximum output voltage: DC 4.2 V
Output voltage: DC 3.6 V
Maximum charge voltage: DC 4.2 V
Maximum charge current: 1.89 A
Capacity: 4.5 Wh (1240 mAh)
Type: Li-ion

[General]

- Waterproof performance: Depth of water 10 m (33 feet), 60 minutes continuously (In use with the waterproof case (SPK-X1))
- Splashproof performance: Equivalent to IPX4*
- Operating temperature: -10 °C to +40 °C (14 °F to 104 °F)
- Storage temperature: -20 °C to +60 °C (-4 °F to +140 °F)
- Dimensions: Approx. 24.4 mm × 51.7 mm × 88.9 mm (31/32 in. × 2 1/8 in. × 3 1/2 in.) (W/H/D, including protrusions)
- Mass: Approx. 89 g (3.1 oz) (camera only)
- Mass (when shooting): Approx. 114 g (4.0 oz) (including NP-BX1 (supplied))
- Microphone: Stereo
- Speaker: Monaural

* Splashproof performance is based on standard testing by Sony.

[Wireless LAN]

- Corresponding standard: IEEE 802.11b/g/n
- Frequency: 2.4 GHz
- Supported security protocols: WPA-PSK/WPA2-PSK
- Configuration method: WPS (Wi-Fi Protected Setup)
- Access method: Infrastructure Mode
- NFC: NFC Forum Type 3 Tag compliant

[Accessories]

Waterproof Case (SPK-X1)

- Dimensions: Approx. 39.0 mm × 74.3 mm × 95.9 mm (1 9/16 in. × 3 in. × 3 7/8 in.) (W/H/D, including protrusions)
- Mass: Approx. 84 g (3 oz)
- Pressure-resistance: Shooting underwater at a depth of 10 m (33 feet) for 60 continuous minutes is possible.*

* When the camera is inserted.

Attachment Buckle:

- Dimensions: Approx. 47.0 mm × 14.0 mm × 58.5 mm (1 7/8 in. × 9/16 in. × 2 3/8 in.) (W/H/D, including protrusions)
- Mass: Approx. 16 g (0.57 oz)

Flat Adhesive Mount:

- Dimensions: Approx. 53.0 mm × 13.0 mm × 58.5 mm (2 1/8 in. × 17/32 in. × 2 3/8 in.) (W/H/D, including protrusions)
- Mass: Approx. 16 g (0.57 oz)

Curved Adhesive Mount:

- Dimensions: Approx. 53.0 mm × 15.5 mm × 58.5 mm (2 1/8 in. × 5/8 in. × 2 3/8 in.) (W/H/D, including protrusions)
- Mass: Approx. 16 g (0.57 oz)

HDR-AS200V

[System]

Video signal:

- HDTV
- NTSC color, EIA standards
- PAL color, CCIR standards

Image device:

- 1/2.3 type (7.81 mm) Exmor R CMOS sensor
- Pixel Gross: Approx. 12.8 megapixels
- Effective picture resolution (movie): Approx. 8.8 megapixels (16:9) (SteadyShot is set to [OFF])
- Effective picture resolution (still): Approx. 8.79 megapixels (16:9)
- Still image max effective: Approx. 8.79 megapixels (16:9)
- Interval photo recording mode: Approx. 2.07 megapixels (16:9)

Lens:

- ZEISS Tessar Lens
- Aperture: F2.8
- Focal distance: f = 2.8 mm
- Focal length (35 mm equivalent) (Movie mode): f = 17.1 mm (16:9) (Movie, SteadyShot is set to [OFF])
- FOV: 170° (SteadyShot is set to [OFF])

Camera:

- Exposure control: Automatic exposure
- Minimum illumination: 6 lx (lux)
- Image stabilization: Electronic SteadyShot image stabilization
- Minimum shooting distance: Approx. 30 cm (11 7/8 in.)

File format:

- Movies: MP4: MPEG-4 AVC/H.264, XAVC S: MPEG-4 AVC/H.264
- Audio: MPEG-4 AAC-LC 2ch (When recording MP4 movies), LPCM 2ch (When recording XAVC S)

movies)

- Still images: JPEG (DCF Ver. 2.0, Exif Ver. 2.3, MPF Baseline) compliant

Recording media:

- When recording MP4 movies:
Memory Stick Micro (Mark2) media
microSD/SDHC/SDXC card (Class4 or faster)
- When recording XAVC S (50Mbps) movies:
microSDXC card (Class10 or faster)

[Input and Output connectors]

- Multi/Micro USB Terminal*: micro-B/USB2.0 Hi-Speed
(Supports Micro USB compatible devices.)

*USB connection is only for output. (For customers in some countries/regions)

[Power]

Power requirements:

- Rechargeable battery pack: 3.6 V (NP-BX1 (supplied))
- Multi/Micro USB Terminal: 5.0 V

Charging method:

- USB charging: DC 5.0 V, 500 mA/800 mA

Charging time:

- Via a computer
NP-BX1 (supplied): Approx. 4 h 5 min.
- Via the AC-UD10 (sold separately)
NP-BX1 (supplied): Approx. 2 h 55 min.

Power supply method:

- USB power supply (1.5 A or more is recommended)

Power consumption:

- 2.0 W (when the image quality is "MP4 HQ 1920 × 1080/30p")

Battery:

- Rechargeable battery pack: NP-BX1 (supplied)
Maximum output voltage: DC 4.2 V
Output voltage: DC 3.6 V
Maximum charge voltage: DC 4.2 V
Maximum charge current: 1.89 A
Capacity: 4.5 Wh (1240 mAh)
Type: Li-ion

[General]

- Waterproof performance: Depth of water 5 m (16 feet), 30 minutes continuously (In use with the waterproof case (SPK-AS2))
- Splashproof performance: Equivalent to IPX4*
- Operating temperature: -10 °C to +40 °C (14 °F to 104 °F)
- Storage temperature: -20 °C to +60 °C (-4 °F to +140 °F)
- Dimensions: Approx. 24.2 mm × 46.5 mm × 81.5 mm (31/32 in. × 1 7/8 in. × 3 1/4 in.) (W/H/D, including protrusions)
- Mass: Approx. 68 g (2.4 oz) (camera only)
- Mass (when shooting): Approx. 93 g (3.3 oz) (including NP-BX1 (supplied))
- Microphone: Stereo

- Speaker: Monaural

* Splashproof performance is based on standard testing by Sony.

[Wireless LAN]

- Corresponding standard: IEEE 802.11b/g/n
- Frequency: 2.4 GHz
- Supported security protocols: WPA-PSK/WPA2-PSK
- Configuration method: WPS (Wi-Fi Protected Setup)
- Access method: Infrastructure Mode
- NFC: NFC Forum Type 3 Tag compliant

[Accessories]

Tripod Adaptor:

- Dimensions: Approx. 23.0 mm × 14.0 mm × 48.7 mm (29/32 in. × 9/16 in. × 1 15/16 in.) (W/H/D, excluding protrusions)
- Mass: Approx. 12 g (0.4 oz)

Waterproof Case (SPK-AS2)

- Dimensions: Approx. 35.5 mm × 62.0 mm × 96.0 mm (1 7/16 in. × 2 1/2 in. × 3 7/8 in.) (W/H/D, including protrusions)
- Mass: Approx. 55 g (2 oz)
- Pressure-resistance: Shooting underwater at a depth of 5 m (16 feet) for 30 continuous minutes is possible.*

* When the camera is inserted.

Attachment Buckle:

- Dimensions: Approx. 47.0 mm × 14.0 mm × 58.5 mm (1 7/8 in. × 9/16 in. × 2 3/8 in.) (W/H/D, including protrusions)
- Mass: Approx. 16 g (0.57 oz)

Flat Adhesive Mount:

- Dimensions: Approx. 53.0 mm × 13.0 mm × 58.5 mm (2 1/8 in. × 17/32 in. × 2 3/8 in.) (W/H/D, including protrusions)
- Mass: Approx. 16 g (0.57 oz)

Curved Adhesive Mount:

- Dimensions: Approx. 53.0 mm × 15.5 mm × 58.5 mm (2 1/8 in. × 5/8 in. × 2 3/8 in.) (W/H/D, including protrusions)
- Mass: Approx. 16 g (0.57 oz)

Design and specifications are subject to change without notice.

[102] How to use | Others | Trademarks

Trademarks

- Memory Stick and  are trademarks or registered trademarks of Sony Corporation.
- The terms HDMI and HDMI High-Definition Multimedia Interface, and the HDMI logo are trademarks or registered trademarks of HDMI Licensing LLC in the United States and other countries.
- Microsoft, Windows and Windows Vista are either registered trademarks or trademarks of Microsoft

Corporation in the United States and/or other countries.

- Mac is a registered trademark of Apple Inc. in the United States and other countries.
- Intel, Pentium and Intel Core are trademarks of Intel Corporation in the U.S. and/or other countries.
- Adobe, the Adobe logo, and Adobe Acrobat are either registered trademarks or trademarks of Adobe Systems Incorporated in the United States and/or other countries.
- microSDXC logo is a trademark of SD-3C, LLC.
- The N Mark is a trademark or registered trademark of NFC Forum, Inc. in the United States and in other countries.
- iPad are trademarks of Apple Inc., registered in the U.S. and other countries.
- iOS is a registered trademark or trademark of Cisco Systems, Inc.
- Android and Google Play are trademarks of Google Inc.
- Wi-Fi, the Wi-Fi logo and Wi-Fi PROTECTED SET-UP are registered trademarks of the Wi-Fi Alliance.
- “” and “PlayStation” are registered trademarks of Sony Computer Entertainment Inc.

In addition, system and product names used in this manual are, in general, trademarks or registered trademarks of their respective developers or manufacturers. However, the ™ or ® marks may not be described in this manual.



[103] How to use | Others | Notes on License

On GNU GPL/LGPL applied software

The software that is eligible for the following GNU General Public License (hereinafter referred to as “GPL”) or GNU Lesser General Public License (hereinafter referred to as “LGPL”) are included in the camera.

This informs you that you have a right to have access to, modify, and redistribute source code for these software programs under the conditions of the supplied GPL/LGPL.

Source code is provided on the web. Use the following URL to download it.

<http://oss.sony.net/Products/Linux>

We would prefer you do not contact us about the contents of source code.

Copies of the licenses (in English) are stored in the internal memory of your camera.

Establish a Mass Storage connection between your camera and a computer, and read the files in the “LICENSE” folder in “PMHOME.”

[104] Troubleshooting | List of Default Setting | List of Default Setting

List of Default Setting

The default setting of every setting item is as follows.

Image quality setting

- 1080 30p HQ (When you set [V.FMT] to [MP4])
- 1080 60p/50p 50M (When you set [V.FMT] to [HD])
- 2160 30p/25p 60M (When you set [V.FMT] to [4K]) (FDR-X1000V only)

Movie format

- MP4

SteadyShot

- ON

Audio recording

- ON

Wind noise reduction

- OFF

Color mode

- VIVID

Loop recording time

- 5min

Still image mode switching

- SINGL

Still image shooting interval

- 10f1s

Self-timer

- OFF

Still image angle of view

- 120°

Interval photo recording

- 2sec

Flip

- OFF

Scene

- NORML

White balance

- AWB

AE shift

- 0.0

Wi-Fi connection

- ON

GPS log

- ON

Airplane mode

- OFF

Mount

- BODY

Time Code/User Bit

- OFF (When you set [DISP])
- DF (When you set [FORMT] of [TCSET])
- REC (When you set [RUN] of [TCSET])
- PrSet (When you set [MAKE] of [TCSET])
- OFF (When you set [T.REC] of [UBSET])

IR-Remote Control

- OFF

HDMI settings

- AUTO(When you set [RESOL])
- 60p (When you set [24/60])
- OFF (When you set [TCOUT])
- OFF(When you set [R.CTL])

USB Power Supply

- ON

Auto power off

- 60sec

Beep

- ON

Daylight saving time (Summer time) setting

- OFF

Language setting

- EN

Switching NTSC/PAL

- NTSC

Troubleshooting

If you experience trouble with the camera, try the following solutions.

1. Check the items of troubleshooting and inspect the camera.
 2. Turn the power off this unit and then on again one minute later.
 3. Consult your Sony dealer or local authorized Sony service facility by phone.
-

[106] Troubleshooting | Troubleshooting | Battery pack and power Cannot turn on the camera.

- Attach a charged battery pack.
 - Make sure that the battery pack is inserted correctly.
-

[107] Troubleshooting | Troubleshooting | Battery pack and power The power turns off suddenly.

- Depending on the camera and battery temperature, the power may turn off automatically to protect the camera. In this case, a message is displayed on the display panel before the power turns off.
 - If you do not operate the camera for a certain period of time while the power is on, the camera turns off automatically to prevent wearing down the battery pack. Turn the camera on again.
 - If you have selected [OFF] in the auto power off function, the power does not turn off automatically.
-

[108] Troubleshooting | Troubleshooting | Battery pack and power Battery life is short.

- You are using the camera in an extremely hot or cold location, or the charging is insufficient. This is not a malfunction.
 - If you have not used the camera for a prolonged period, the efficiency of the battery will be improved by repeatedly charging and discharging it.
 - When usable battery life becomes half the usual time, even after charging the battery pack fully, the battery pack may need to be replaced. Consult your nearest Sony dealer.
-

Cannot charge the camera.

- Turn off the camera and make the USB connection.
 - Disconnect the micro USB cable (supplied), and then reconnect it.
 - Use the micro USB cable (supplied).
 - Charge the battery pack in an ambient temperature of 10°C to 30°C (50°F to 86°F).
 - Turn on the computer and connect the camera.
 - Release the computer from sleep or hibernation status.
 - Connect the camera directly to a computer using the micro USB cable (supplied).
 - Connect the camera to a computer with the operating system that is supported by the camera.
-

The remaining charge indicator is incorrect.

- This phenomenon occurs when you use the camera in an extremely hot or cold location.
 - A discrepancy arose between the remaining charge indicator and the actual remaining battery charge. Fully discharge the battery pack once, then charge it to correct the indication.
 - Fully charge the battery pack again. If the problem persists, the battery pack is worn out. Replace the battery pack with a new one.
-

Operations using the memory card cannot be performed.

- If you use a memory card formatted on a computer, format it again on the camera.
-

Cannot record images.

- Check the free capacity of the memory card.
-

Cannot insert dates on images.

-
- The camera does not have a feature for superimposing dates on images.

[114] Troubleshooting | Troubleshooting | Viewing images

Cannot playback images.

-
- The folder/file name has been changed on your computer.
 - Connect a micro HDMI cable (sold separately).

[115] Troubleshooting | Troubleshooting | Viewing images

The image does not appear on the TV.

-
- Check whether the connection is correct.

[116] Troubleshooting | Troubleshooting | GPS

The camera is not receiving a GPS signal.

-
- Set the GPS log to [ON].
 - Your camera may not be able to receive radio signals from GPS satellites because of obstructions.
 - To triangulate the location information correctly, bring your camera to an open area, and turn on the camera again.

[117] Troubleshooting | Troubleshooting | GPS

Excessive error in location information.

-
- The margin of error can be up to several-hundred meters depending on surrounding buildings, weak GPS signals, etc.

[118] Troubleshooting | Troubleshooting | GPS

It takes time to triangulate although the GPS assist data

is taken in.

- Date & Time Setting is not set, or set time is shifted greatly. Set the date and time correctly.
 - The term of validity of GPS assist data has expired. Update GPS assist data.
 - As the positions of GPS satellites vary constantly, it may take longer to determine the location or the receiver may not be able to determine the location at all, depending on the location and time you use the camera.
 - GPS is a system for determining geographic location by triangulating radio signals from GPS satellites. Avoid using the camera in places where radio signals are blocked or reflected, such as a shadowy place surrounded by buildings or trees, etc. Use the camera in open sky environments.
-

[119] Troubleshooting | Troubleshooting | GPS

The location information has not been recorded.

- Use PlayMemories Home to import the movies with GPS location information to your computer.
-

[120] Troubleshooting | Troubleshooting | Computers

Your computer does not recognize the camera.

- When the battery level is low, charge the camera.
 - Turn on the camera and connect to a computer.
 - Use the micro USB cable (supplied).
 - Disconnect the micro USB cable (supplied) from both the computer and the camera, and connect it again firmly.
 - Disconnect all equipment other than the camera, the keyboard and the mouse from the USB connectors of your computer.
 - Connect the camera directly to your computer without passing through a USB hub or other device.
-

[121] Troubleshooting | Troubleshooting | Computers

Cannot import images.

- Connect the camera and your computer correctly making a USB connection.
-

[122] Troubleshooting | Troubleshooting | Computers

Action Cam Movie Creator cannot be installed.

- Check the computer environment or installation procedure required to install Action Cam Movie Creator.
-

[123] Troubleshooting | Troubleshooting | Computers

Action Cam Movie Creator does not work correctly.

- Quit Action Cam Movie Creator and restart your computer.
-

[124] Troubleshooting | Troubleshooting | Computers

Cannot play back images on your computer.

- Consult the computer or software manufacturer.
-

[125] Troubleshooting | Troubleshooting | Wi-Fi

It takes too much time to transfer an image.

- Microwave ovens or Bluetooth-enabled devices use the 2.4 GHz wavelength and could hinder the communication. If such devices are in the vicinity, move the camera away from those devices or shut those devices down.
-

[126] Troubleshooting | Troubleshooting | Others

The lens gets fogged.

- Moisture condensation has occurred. Turn off the camera and wait about an hour for the moisture to evaporate.
-

[127] Troubleshooting | Troubleshooting | Others

The camera becomes warm when you use it for a long

time.

- This is not a malfunction.
-

[128] Troubleshooting | Troubleshooting | Others

The date or time is incorrect.

- Set the date and time again.
-

[129] Troubleshooting | Warning indicators and messages | Warning indicators and error messages

Warning indicators and error messages

Battery indicator (Remaining battery is low)

- When the battery level is low,  is displayed. Charge the battery pack immediately.

ERROR

- Turn the power off and then on again.
- An unknown error has occurred on USTREAM, when using the Live Streaming function. Wait a moment and then try confirming the connection again.

HEAT

- The camera temperature has risen. The power may turn off automatically, or you may be unable to record images.
Leave the camera in a cool location until the temperature goes down.
- If you record images for an extended period, the camera temperature rises. In this case, stop recording images.

NoIMG

- The memory card does not contain playable images.

LowPw

- There is no remaining battery charge.

BATT

- Battery charge is insufficient for operation.
- The battery pack is delivering current exceeding the maximum discharge current (beyond which proper operation of the camera cannot be assured when an external microphone, etc., is connected).
- A different battery pack is detected when the camera is powered on.
- Battery pack deterioration is detected.

SHORT

- The remaining capacity of the memory card is insufficient for loop recording.

FULL

- Remaining capacity of the memory card is insufficient for recording.

MAX

- The maximum number of files that can be recorded has been reached.

MEDIA

- The memory card is not inserted properly.
- The memory card is damaged.
- The memory card does not support XAVC S movie recording.

NoCRD

- There is no memory card inserted.

NoDSP

- The camera is not connected to a TV when playback is started.

PLANE

- When the airplane mode is set to [ON], GPS and Wi-Fi cannot be used.

NoSET

- Set the necessary settings for USTREAM using “Camera Settings for Live Streaming” of the Action Cam Movie Creator’s camera settings.

Auth

- Log in to USTREAM again and confirm the settings using “Camera Settings for Live Streaming” of the Action Cam Movie Creator’s camera settings.

CHANL

- The channel set by “Camera Settings for Live Streaming” of the Action Cam Movie Creator’s camera settings is incorrect.
- This message also displays if other media starts streaming on the same channel while streaming from your camera is performed.
- Set the channel again.

DATE

- Set the date and time again on your camera.

APErr

- Access point has been found but is not connected. Check the password of the access point and connect again.

PREP

- The network is temporarily unavailable.

Netwk

- The saving settings of video cannot be saved to USTREAM because an error has occurred on the

network.

- Some other network error has occurred.
- Confirm the setting of the access point or the security of the access point using “Camera Settings for Live Streaming” of the Action Cam Movie Creator’s camera settings.

NO AP

- Access point cannot be found. Confirm the setting of the access point using “Camera Settings for Live Streaming” of the Action Cam Movie Creator’s camera settings.

LIMIT

- The total time of saved video on USTREAM has reached the limit. Stop streaming video.

TWErr

- Twitter post error has occurred.
- Check the network or log in to Twitter again.

FBErr

- Facebook post error has occurred.
- Check the network or log in to Facebook again.