

# F4U-1D Corsair 50 ARF

*Assembly Manual*



**HANGAR 9<sup>®</sup>**

## Notice

All instructions, warranties and other collateral documents are subject to change at the sole discretion of Horizon Hobby, Inc. For up-to-date product literature, visit <http://www.horizonhobby.com> and click on the support tab for this product.

## Meaning of Special Language

The following terms are used throughout the product literature to indicate various levels of potential harm when operating this product:

**NOTICE:** Procedures, which if not properly followed, create a possibility of physical property damage AND a little or no possibility of injury.

**CAUTION:** Procedures, which if not properly followed, create the probability of physical property damage AND a possibility of serious injury.

**WARNING:** Procedures, which if not properly followed, create the probability of property damage, collateral damage, and serious injury OR create a high probability of superficial injury.



**WARNING:** Read the ENTIRE instruction manual to become familiar with the features of the product before operating. Failure to operate the product correctly can result in damage to the product, personal property and cause serious injury.

This is a sophisticated hobby product and NOT a toy. It must be operated with caution and common sense and requires some basic mechanical ability. Failure to operate this Product in a safe and responsible manner could result in injury or damage to the product or other property. This product is not intended for use by children without direct adult supervision. Do not attempt disassembly, use with incompatible components or augment product in any way without the approval of Horizon Hobby, Inc. This manual contains instructions for safety, operation and maintenance. It is essential to read and follow all the instructions and warnings in the manual, prior to assembly, setup or use, in order to operate correctly and avoid damage or serious injury.

## Table of Contents

Introduction .....	2
Product Support .....	2
Specifications.....	2
Included Parts Listing .....	3
Contents of Kit and Parts Listing .....	4
Safety Precautions and Warnings .....	4
Important Information Regarding Warranty.....	5
Using the Manual.....	5
UltraCote Covering Colors .....	5
Recommended Power Setups.....	5
Transmitter Requirements.....	5
Radio Equipment Requirements .....	5
Field Equipment Required .....	5
Optional Equipment .....	5
Optional Field Equipment .....	6
Required Tools.....	6
Required Adhesives .....	6
Before Starting Assembly .....	6
Binding the Radio System .....	6
Assembling the Wing.....	6
Hinging the Ailerons .....	8
Aileron Servo Installation.....	10
Aileron Linkage Installation.....	13
Fixed Main Landing Gear Installation.....	15
Retract Installation.....	19
Wing Installation.....	25
Stabilizer and Elevator Installation .....	27
Fin and Rudder Installation.....	32
Receiver, Receiver Battery, Servo and Linkage Installation.....	37
Engine and Fuel Tank Installation.....	42
Motor and Battery Installation .....	46
Cowling Installation .....	49
Pilot, Canopy and Antenna Mast Installation .....	52
Radiator and Gun Installation .....	54
Decal Installation .....	56
Center of Gravity.....	57
Control Throws .....	57
Preflight .....	58
Range Test Your Radio .....	58
Safety Do's and Don'ts for Pilots .....	58
Daily Flight Checks.....	58
Warranty and Repair Policy .....	59
Warranty Services.....	59
Compliance Information for the European Union.....	60
Academy of Model Aeronautics National Model Aircraft Safety Code .....	60

## Introduction

To many, the Chance Vought F4U-1D Corsair was the ultimate expression of U.S. air power in the Pacific during World War II. Its top speed of well over 400 mph combined with its ability to carry a wide variety of weapon loadouts made it a serious threat to enemy units in the air and on the ground.

The Hangar 9 F4U-1D Corsair 50 is a sport ARF tribute to this warbird legend that goes together quickly and is a joy to fly. Its low parts count makes assembly a breeze and it boasts details you usually only find on much pricier kits. These details include a painted fiberglass cowl with molded cowl flaps, a dummy radial engine and oil cooler intakes on the wing roots, just to name a few. You even get two sets of aircraft numbers to finish the model with.

The F4U-1D Corsair 50 also gives you the freedom to power it with a variety of options that include glow and gas engines as well as brushless electric motors. It's been designed to accept all of them with little or no modification.

## Product Support

For technical assistance with this product, please contact the appropriate Horizon Product Support office. This information is located in the back of this manual.

## Specifications

Wingspan	57.0 in (145cm)
Wing Area	620 sq in.(39.9 sq dm)
Fuselage Length	45.5 in (115cm)
Weight Range	6.75 lb–8.00 lb (3.10–3.60 kg)
Engine/Motor Size	2-stroke glow: .46–.55 4-stroke glow: .72–.82 4-stroke gas: FG-14B EP: Power 46
Radio	4+ channel with 5 servos (4 servos for EP)

## Included Parts Listing

<b>FUSELAGE</b>	<b>QUANTITY</b>	<b>USAGE</b>
3mm plywood plate	1	EP battery tray support
3mm plywood plate	1	EP battery tray
3mm plywood brace	1	Fuel tank rear brace
3mm plywood support	1	Fuel tank top support
Nylon engine mount	2	
6-32 x 3/4-inch socket head cap screw	4	EP standoff and engine mount to firewall
6-32 blind nuts	4	EP standoff and engine mount to firewall
4-40 x 1-inch socket head cap screw	4	Engine to mount
#4 Flat washer	4	Engine mount
4-40 lock nuts	4	Engine to mount
#6 flat washers	4	EP motor mount
62mm wood standoff box	1	EP motor mount
Plywood engine template	3	EP, glow and 4-stroke gas
2mm x 10mm black washer head screw	4	Fuel tank brace
3mm x 15mm black washer head screw	4	Cowl
Pushrod connector w/hardware	1	Throttle servo pushrod
3mm x 12mm machine screw	2	EP battery tray
3mm flat washer	2	EP Battery tray
3mm plywood bracket	1	Ignition switch mount
3mm plywood support (optional)	1	Air cylinder
15mm x 20mm plywood bracket	1	Fuel vent line bracket
Balsa fairing – Blue	1	Rudder fairing
3mm x 65mm plywood – Blue	1	Antenna mast
Velcro straps	2	Receiver and battery
260cc assembled tank	1	Glow fuel tank
1/4 x 28 spinner nut	1	2-stroke engine spinner
<b>ELEVATOR</b>	<b>QUANTITY</b>	<b>USAGE</b>
2mm x 15mm screw	3	Control horn elevator
3mm metal joiner rod	1	Elevator joiner rod
Safety tubing needed	2	Cut into 1/4-inch pieces as needed
Nylon clevis	5	Elevator, Throttle and Tail wheel
Control horns	1	Elevator
<b>PUSHRODS</b>	<b>QUANTITY</b>	<b>USAGE</b>
2mm x 505mm pushrod	1	Rudder
2mm x 610mm pushrod	1	Elevator
2mm x 215mm pushrod	1	Throttle
2mm x 53mm pushrod	2	Aileron
Pushrod housing 8-inch (200mm)	1	Throttle

<b>WING</b>	<b>QUANTITY</b>	<b>USAGE</b>
6mm x 30mm dowels	2	Wing
2mm x 10mm black washer head screw	8	Aileron servo hatch
3mm plywood doubler	1	Wing bolt
Plastic radiators - blue	2	1 left 1 right
Plastic machine guns	2	
Wheel well - blue	2	Wheel well liner (left and right)
Clear template	2	Retract wheel well (left and right)
8-32 x 1 1/4-inch socket head cap screw	2	Wing mount
8-32 blind nuts	2	Wing mount
#8 flat washer	2	Wing mount
2mm x 10mm wood screw	6	Aileron control horn mounting screws
6mm plywood joiner	2	Wing panel to center section spar joiner
10mm x 17mm x 20mm wood block	4	Aileron servo
Control horns	2	Aileron
Nylon clevis	2	Aileron
<b>LANDING GEAR</b>	<b>QUANTITY</b>	<b>USAGE</b>
2mm plywood doors - blue	2	Main wheel
4mm wheel collars with screw	4	Main wheel
2.5mm wheel collars	2	Tail wheel and tail wheel wire mount
3mm tail wire with 1-inch (25mm) wheel	1	Tail wheel
Tail wheel adapter with setscrew	1	Tail wheel/rudder
3mm torque rod	1	Rudder
1.5mm hex wrench	1	
2.0mm hex wrench	1	
3mm x 15mm black counter sunk screws	4	Fixed gear
3mm x 20mm black counter sunk screws	4	Fixed gear
Metal brackets	2	Door attachment
2mm x 10mm machine screw	4	Door attachment
2mm nut	4	Door attachment
2mm flat washer	4	Door attachment
<b>BAGGED SEPARATELY AND NOT LABELED QUANTITY</b>	<b>QUANTITY</b>	<b>USAGE</b>
3 1/2-inch (89mm) wheel	2	Main wheels
Fiberglass belly pan	1	Wing to fuselage
Headrest plastic with balsa insert	1	Fuselage
Cowl	1	
Canopy	1	
Dummy engine	1	

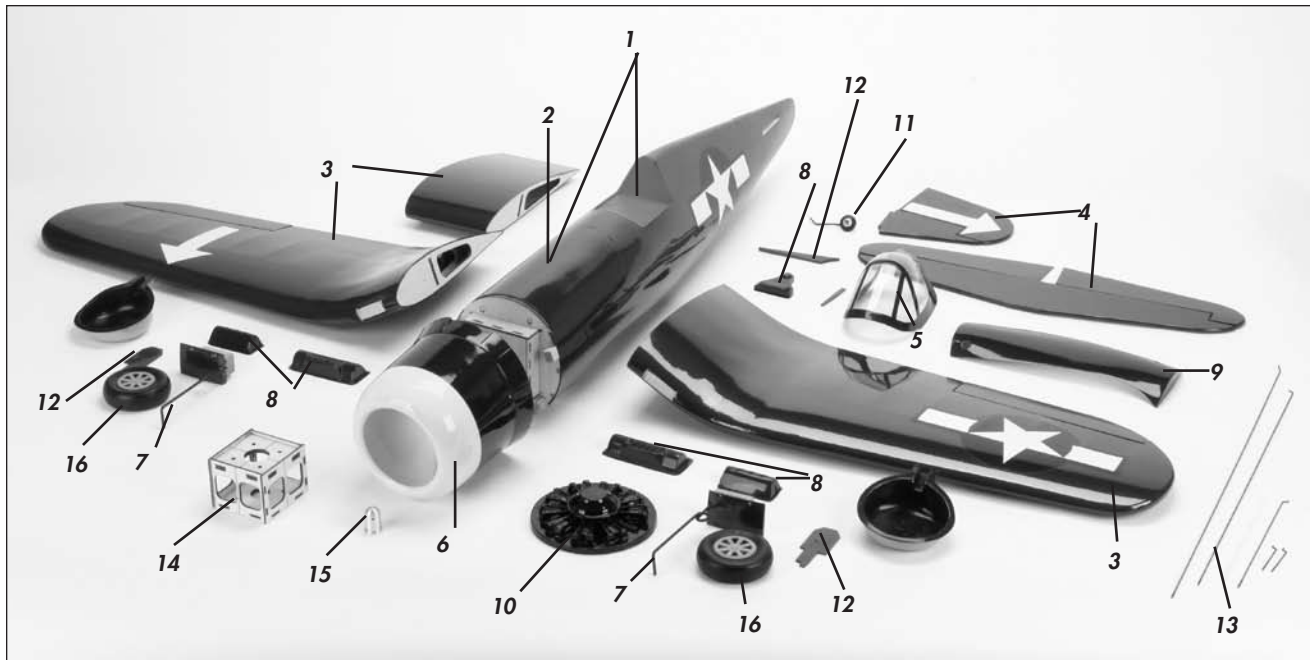

## Contents of Kit and Parts Listing

### Replacement Parts

1. HAN259001	Fuselage with Hatch
2. HAN259002	Fuselage Hatch
3. HAN259003	Complete Wing Assembly
4. HAN259004	Tail Set
5. HAN259005	Canopy
6. HAN259006	Cowl
7. HAN259007	Fixed Landing Gear Struts
8. HAN259008	Wing Radiators, Guns and Headrest
9. HAN259009	Belly Pan
10. HAN259010	Dummy Radial Engine
11. HAN259012	Tail Wheel Assembly with Wheel
12. HAN259013	Main Gear Doors and Fin Fillet
13. HAN259015	Pushrod Set
14. HAN259018	EP Motor Mount Box
15. HAN259021	3/4-inch Spinner Nut, 1/4-28
16. HAN242022	3 1/2-inch (89mm) 8-Spoke Wheel Set

### Items Not Shown

HAN259011	11 oz (320cc) Fuel Tank
HAN259014	Plywood Trays
HAN259016	Decal Set
HAN259017	Engine Mount
HAN259019	Engine/Motor Templates
HAN259020	Hardware Package
HAN259022	3/4-inch Spinner Nut, 8 x 1.25mm
HAN259023	3/4-inch Spinner Nut, 7 x 1mm

## Safety Precautions and Warnings

Read and follow all instructions and safety precautions before use. Improper use can result in fire, serious injury and damage to property.

Age Recommendation: Not for children under 14 years. This is not a toy.

### COMPONENTS

Use only with compatible components. Should any compatibility questions exist please refer to the product instructions, the component instructions or contact Horizon Hobby, Inc.

### FLIGHT

Fly only in open areas to ensure safety. It is recommended flying be done at AMA (Academy of Model Aeronautics) approved flying sites. Consult local ordinances before choosing a flying location.

### PROPELLER

Keep loose items that can get entangled in the propeller away from the prop, including loose clothing, or other objects such as pencils and screwdrivers. Especially keep your hands away from the propeller as injury can occur.

### BATTERIES

#### Notes on Lithium Polymer Batteries

When used improperly, lithium polymer batteries are significantly more volatile than alkaline or Ni-Cd/Ni-MH batteries used in RC applications. Always follow the manufacturer's instructions when using and disposing of any batteries. Mishandling of Li-Po batteries can result in fire causing serious injury and damage.

### SMALL PARTS

This kit includes small parts and should not be left unattended near children as choking and serious injury could result.

## Safe Operating Recommendations

- Inspect your model before every flight to make certain it is airworthy.
- Be aware of any other radio frequency user who may present an interference problem.
- Always be courteous and respectful of other users of your selected flight area.
- Choose an area clear of obstacles and large enough to safely accommodate your flying activity.
- Make certain this area is clear of friends and spectators prior to launching your aircraft.
- Be aware of other activities in the vicinity of your flight path that could cause potential conflict.
- Carefully plan your flight path prior to launch.
- Abide by any and all established AMA National Model Aircraft Safety Code.

## Important Information Regarding Warranty

Please read our Warranty and Liability Limitations in the back of this manual before building this product. If you as the purchaser or user are not prepared to accept the liability associated with the use of this Product, you are advised to return this Product immediately in new and unused condition to the place of purchase.

## Using the Manual

This manual is divided into sections to help make assembly easier to understand, and to provide breaks between each major section. In addition, check boxes have been placed next to each step to keep track of each step completed. Steps with a single box (☐) are performed once, while steps with two or more boxes (☐☐) indicate the step will require repeating, such as for a right or left wing panel, two servos, etc. Remember to take your time and follow the directions.

## UltraCote® Covering Colors

Corsair Blue HANU905

## Recommended Power Setups

### 2-STROKE GLOW

Evolution® .52NX with Muffler	EVOE0520
11 x 6 Evolution propeller	EVO11060
Fuel Filler with T-fitting and Overflow	HAN116
3/4-inch spinner nut, 1/4 x 28 (included)	HAN259021

### 4-STROKE GLOW

Saito™ .82 AAC with Muffler	SAIE082B or SAIE082BGK
14 x 6 Evolution propeller	EVO14060
Fuel Filler with T-fitting and Overflow	HAN116

#### Optional:

3/4-inch spinner nut, 7mm x 1mm	HAN259023
---------------------------------	-----------

### 4-STROKE GAS

Saito FG-14B	SAIEG14B
14x6 Evolution propeller	EVO14060
Fuel Filler with T-fitting and Overflow	HAN116
JR Chargeswitch	JRPA004
1350mAh 2S Li-Po	THP13502SPLRX
Gasoline Fuel Stopper	DUB400
Tygon Gas Tubing, 3-ft, Medium	DUB799

#### Optional:

3/4-inch spinner nut, 8mm x 1.25mm	HAN259023
------------------------------------	-----------

### ELECTRIC

Power 46 BL Outrunner Motor, 670Kv	EFLM4046A
60-Amp Pro Switch-Mode BEC ESC	EFLA1060
Propeller Adapter for Power 46/60	EFLM1934
6-inch (152mm) Servo Extension	JSP98110
APC Propeller, 13 x 7	APC13070E
or	
APC Propeller, 14 x 6	APC14060E
4000mAh 4S 14.8V 30C Li-Po, 12AWG	EFLB40004S30
or	
4400mAh 4S 14.8V G4 Pro Power 30C	THP44004SP30

#### Optional:

3/4-inch spinner nut, 8mm x 1.25mm	HAN259022
------------------------------------	-----------

## Transmitter Requirements

This model requires a minimum of a 4-channel radio to operate all the functions of your aircraft. We suggest the following radio systems available through Horizon Hobby or your local hobby distributor.

Spektrum DX6i	SPM6610
Spektrum DX8	SPM8800
JR® DSM2 or DSMX Systems	

## Radio Equipment Requirements

The following items are recommended when installing the 8-Channel AR8000 (SPMAR8000).

JR Chargeswitch	JRPA004
DSMX 8-Channel Receiver, Air	SPMAR8000
DS821 Digital Sport Servo (5)	JRPS821
Receiver Battery, 2300mAh, 3.0V Ni-Cd	JRPB5006
6-inch (152mm) Servo Extension (3)	JSP98110
12-inch (305mm) Servo Extension (2)	JSP98030

### Servo Placement and Extensions:

Aileron:	DS821 Digital Sport Servo (2) 12-inch (305mm) (2) inside wing to servo 6-inch (152mm) (2) receiver to wing extensions
Rudder:	DS821 Digital Sport Servo
Elevator:	DS821 Digital Sport Servo
Throttle:	DS821 Digital Sport Servo (not required for EP installations)
Retracts:	6-inch (152mm) servo extension, receiver to retract Y harness

## Field Equipment Required

Fuel (15% recommended)	
Saito Spark Plug	SAIG20120
Long Reach Glow Plug Wrench	HAN2510
Metered Glow Driver with Ni-Cd & Charger	HAN7101
2-Cycle Sport Plug	EVOGP1
Ultra Fuel Pump (gas and glow)	HAN155
Evolution Oil	EVOX1001Q

## Optional Equipment

E-flite® Electric Retracts, 25–46	EFLG320
1/9-Scale Military Pilot	HAN9108
Telemetry for the DX8	SPM9548

## Optional Field Equipment

PowerPro™ 12V Starter	HAN161
12V 7Ah Sealed Battery	HAN102
Power Panel	HAN106
Blue Block After Run Oil	EVOX1001
Self-stick weights, 6 oz	HAN3626
Charger	EFL3025
Spray cleaner	
Paper towels	

## Required Tools

C-clamp	Covering iron
Cutoff wheel	Denatured alcohol
Dish washing detergent	Drill
Epoxy brush	Felt-tipped pen
Flat file	Hobby knife with #11 blade
Hobby scissors	Light machine oil
Low-tack tape	Medium grit sandpaper
Mixing cup	Mixing sticks
Needle nose pliers	Nut driver: 4mm, 1/4-inch
Paper towels	Pencil
Pin vise	Phillips screwdriver: #1, #2
Propeller reamer	Rotary tool
Ruler	Sanding drum
Side cutter	Spray bottle
Toothpick	T-pins
Two-sided tape	Waxed paper
Drill bit: 1/16-inch (1.5mm), 5/64-inch (2mm), 11/64-inch (4.5mm), 1/4-inch (6mm)	
Hex wrench: 1.5mm (included), 2mm (included), 2.5mm, 3/32-inch, 7/64-inch, 9/64-inch	

## Required Adhesives

30-minute Epoxy	PAAPT39
Canopy Glue	PAAPT56
Silicone adhesive	DEVS250
Thin CA	PAAPT08
Medium CA	PAAPT02
Threadlock	PAAPT42

## Before Starting Assembly

Before beginning the assembly of your model, remove each part from its bag for inspection. Closely inspect the fuselage, wing panels, rudder and stabilizer for damage. If you find any damaged or missing parts, contact the place of purchase.

If you find any wrinkles in the covering, use a heat gun (HAN100) and covering glove (HAN150) or covering iron (HAN101) with a sealing iron sock (HAN141) to remove them. Use caution while working around areas where the colors overlap to prevent separating the colors.

## Binding the Radio System

Before starting the assembly of your model, we recommend preparing your radio system for installation. This includes charging the transmitter and receiver batteries, as well as centering the trims and sticks on your transmitter. If using a computer radio, make sure to reset a model memory and name it for this particular model. We also recommend binding the transmitter and receiver at this time following the instructions provided with your radio system.

**Note:** We highly recommend re-binding the radio system once all the control throws are set. This will keep the servos from moving to their endpoints until the transmitter and receiver connect.

## Assembling the Wing

### Required Parts

Center wing panel	Plywood wing joiner (2)
Covering, blue	
Outer wing panel (right and left)	

### Required Tools and Adhesives

30-minute epoxy	Denatured alcohol
Paper towels	Mixing sticks
Mixing cups	Epoxy brush
Low-tack tape	Covering iron
Hobby knife with #11 blade	

1. Locate the two plywood wing joiners. You will also need the center wing panel as well as the right and left outer wing panels.

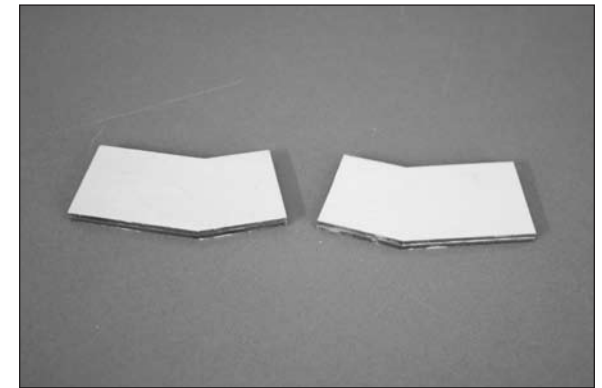

2. The plywood wing joiner will only fit into the panels in one direction. Note that the shorter end fits into the outer panel, while the longer end fits into the center panel.

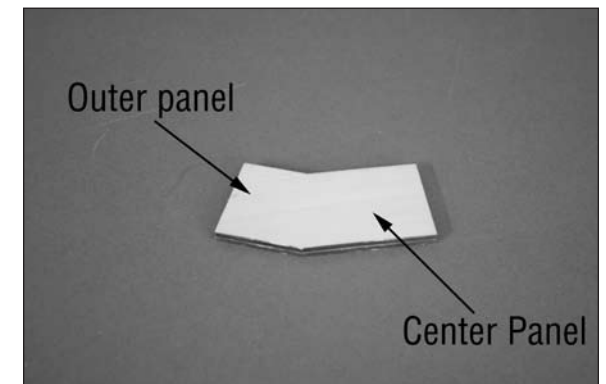

**Note:** Read through this section of the manual BEFORE mixing any epoxy.

□□ 3. Fit the plywood wing joiner into the center wing panel. It will slide in easily so don't force the joiner in any farther than it will easily slide. Note the joiner will angle to the bottom of the wing as shown. The center section is shown upside-down in the photo below.

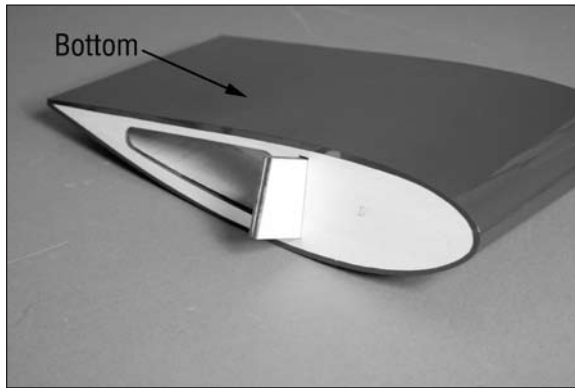

□□ 4. Slide the outer wing panel into position. It will fit tightly against the center wing panel with no gaps between the panels.

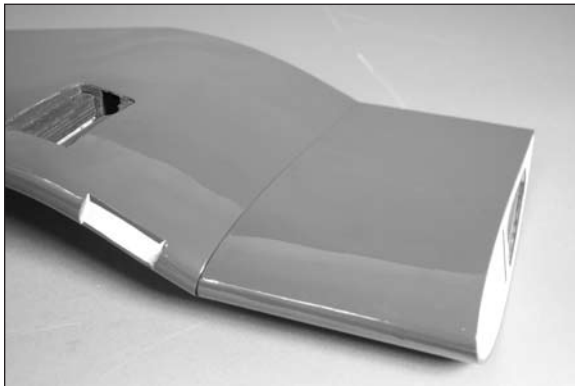

□ 5. Repeat steps 3 and 4 to check the fit of the remaining wing panel to the center panel.

□ 6. Use a hobby knife with a #11 blade to remove the covering from the center panel so the servo leads can pass through the opening.

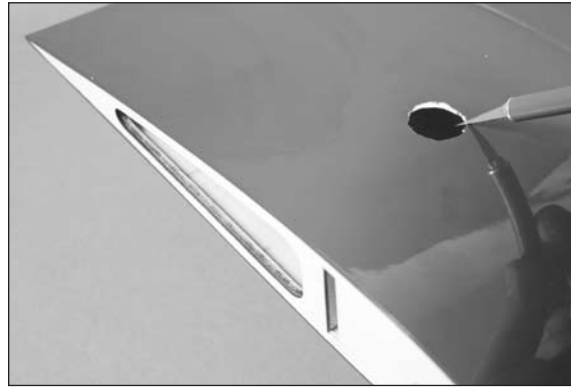

**Note:** It is important the joiner and joiner pockets have epoxy at all points where they come in contact with each other.

□ 7. Separate the wing panels and center panel and remove the wing joiners. Mix 1/2 ounce (15mL) of 30-minute epoxy. Use a mixing stick to apply epoxy in the joiner pockets of both wing panes and the center panel. Make sure epoxy has been applied to all surfaces inside the joiner pockets.



□ 8. Use an epoxy brush to apply epoxy to all sides of the wing joiner. It is important the joiners have epoxy at all points where they come in contact with each other.

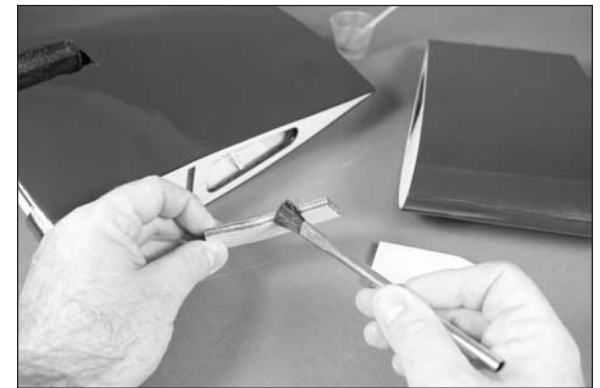
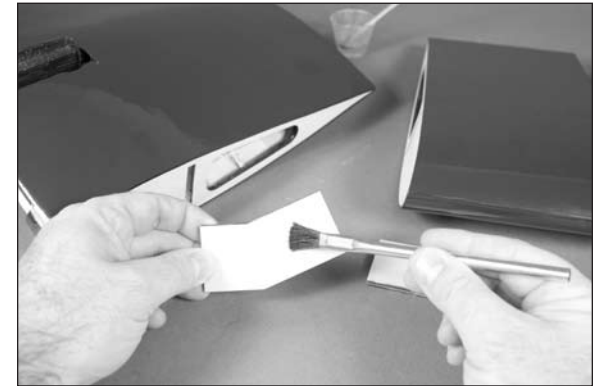

□ 9. Slide the joiner into the center panel. Use an epoxy brush to apply a thin layer of epoxy to the exposed wood of the rib as shown. Apply epoxy to the center panel and to the outer wing panels at this time.

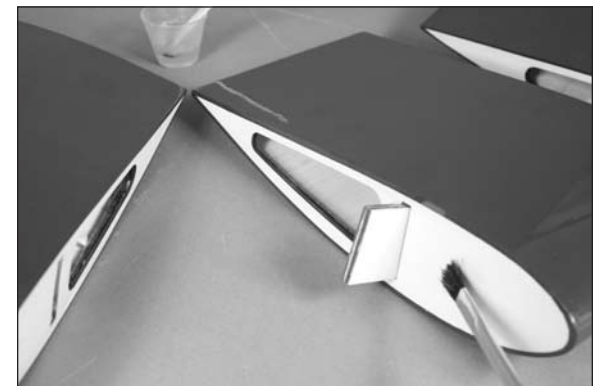

□ 10. Slide the outer and center panels together. Make sure to guide the strings in the wing panels through the hole in the center panel. Wrap a piece of low-tack tape around the leading and trailing edges to keep the panels in alignment. Use a piece of low-tack tape to hold the panels tightly together until the epoxy fully cures.

**Note:** Make sure to support the wing at the center section. If it is resting on the tips, it may change the alignment of the panels while the epoxy cures.

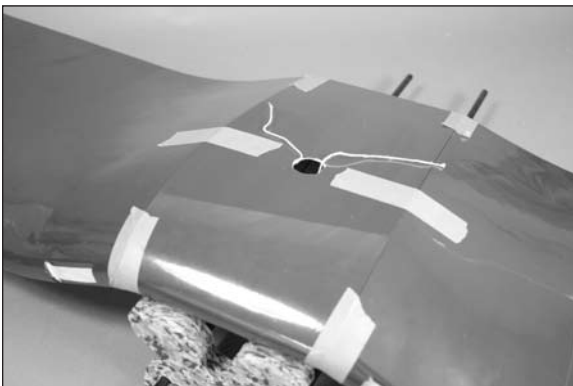
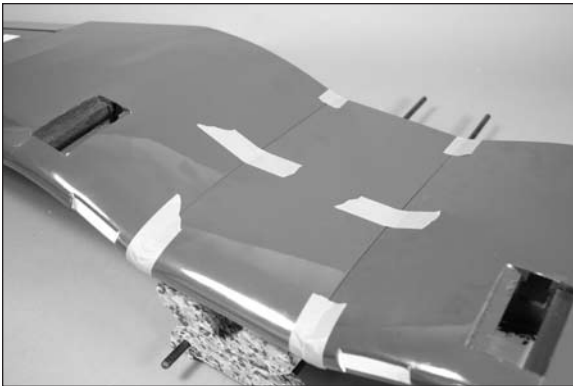

**Hint:** Use low-tack tape to tape the string to the top of the wing to prevent it from falling back into the center section.

□ 11. After the epoxy has been allowed to cure for an hour, remove the tape from the wing panels. Use denatured alcohol to remove any excess epoxy from the wing panels before it has a chance to fully cure.



□ 12. Use a covering iron to apply the two strips of covering over the joint between the outer panels and the center panel starting at the trailing edge and wrapping the covering strip around the leading edge in one piece. This will eliminate any seams which could come loose in flight.



## Hinging the Ailerons

### Required Parts

Assembled wing                      CA hinge (6)

### Required Tools and Adhesives

Pin vise                                      Drill bit: 1/16-inch (1.5mm)  
Thin CA                                      T-pins

**Note:** The aileron has been positioned on the wing for shipping. Please follow the instructions for gluing the hinges. Not following this procedure will result in a poorly installed hinge, which could cause the aileron to come loose in flight.

□ □ 1. Separate the aileron from the wing. Set the three hinges aside at this time.

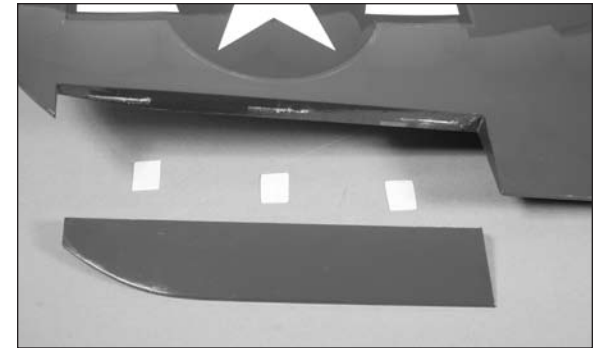

□ □ 2. Use a pin vise and 1/16-inch (1.5mm) drill bit to drill a hole in the center of each hinge slot. This creates a tunnel for the CA to wick into, creating a better bond between the hinge and surrounding wood. Prepare both the slots in the aileron and wing at this time.





□□ 3. Place a T-pin in the center of three hinges. Insert the hinges into the aileron as shown. The hinges have a slot in them and must be installed so the slot is perpendicular to the hinge line of the control surface.

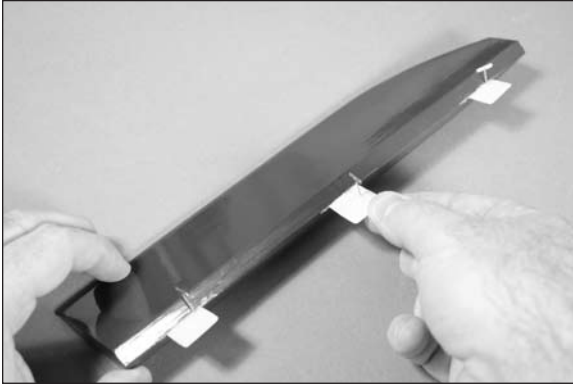

□□ 4. Check the fit of the aileron to the wing panel. The aileron should fit tightly against the wing panel. Remove the T-pins from the hinges. Position the aileron so there is an equal gap between the ends of the aileron and wing panel.

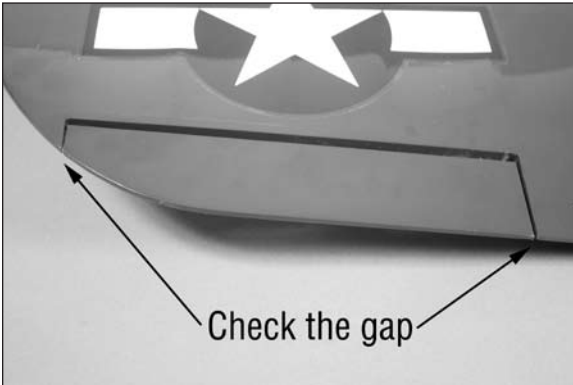

□□ 5. Saturate each of the three hinges on both the top and bottom of the hinge. Set the assembly aside to cure.



**Important:** Allow the CA to cure WITHOUT using CA accelerator. This is necessary to allow the CA to soak into the hinge, creating the best bond between the hinge and surrounding wood.

□□ 6. Once the CA and epoxy has cured, check that all the hinges are secure by gently trying to separate the aileron from the wing panel. If any hinges are loose, re-apply CA to the loose hinges.



□□ 7. Break in the hinges by working the aileron up and down a number of times.

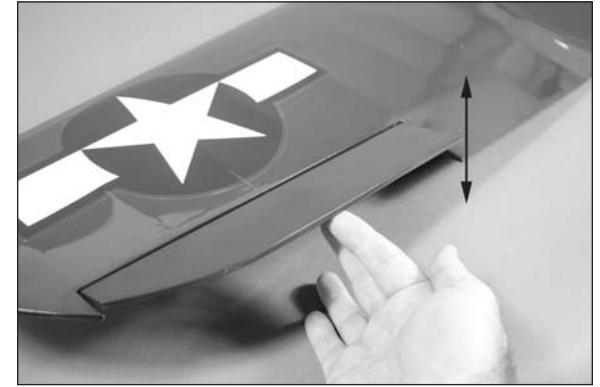

□□ 8. Repeat steps 1 through 7 to hinge the remaining aileron to the wing panel.

## Aileron Servo Installation

### Required Parts

Servo cover (2)	Wing assembly
Transmitter	Receiver
Receiver battery	
Servo extension, 12-inch (305mm) (2)	
10mm x 17mm x 20mm wood block (4)	
2mm x 10mm washer head screw, black (8)	

### Required Tools and Adhesives

Thin CA	30-minute epoxy
Pin vise	Drill
Mixing stick	Side cutter
Pencil	Mixing cup
T-pins	String
Sandpaper	Hobby knife with #11 blade
Phillips screwdriver: #1	Pin vise
Drill bit: 1/16-inch (1.5mm), 5/64-inch (2mm)	

□ 1. Locate the screws and hardwood blocks to attach the servos to the servo covers and to mount the covers in the wing panel. The wing assembly is also required for this section of the manual.

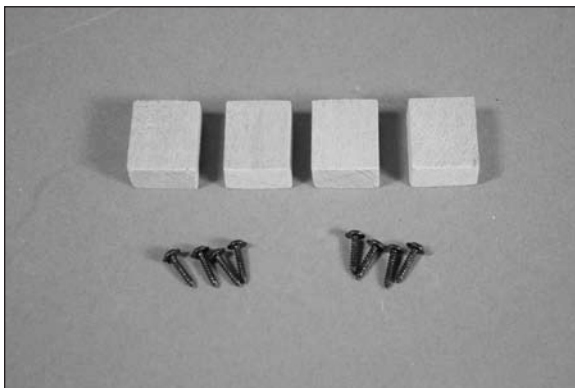

□□ 2. Remove the servo cover from the wing by removing the tape holding it in position on the wing.



□□ 3. Use a hobby knife with a #11 blade to remove the covering for the servo horn to pass through the servo cover.

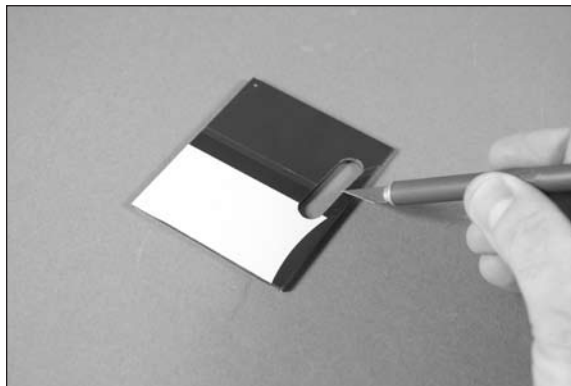

□□ 4. Prepare the aileron servo by installing the rubber grommets and brass eyelets as shown in the radio or servo instructions. Center the aileron servo using the radio system. Enlarge the hole in the servo arm using a pin vise and 5/64-inch (2mm) drill bit that is 5/8-inch (15mm) from the center of the servo horn. Use side cutters to remove any arms from the horn that may interfere with the operation of the servo.



□□ 5. Place the servo on the cover, centering the servo horn in the opening. Use a pencil to mark the locations for the servo mounting blocks on the servo cover.

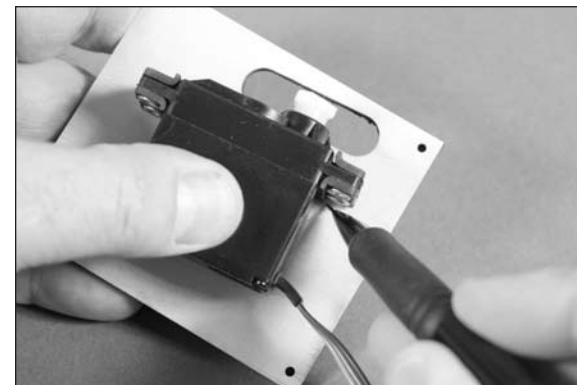

□□ 6. Lightly sand the end of the block using medium grit sandpaper. Sand the end grain as shown in the drawing.

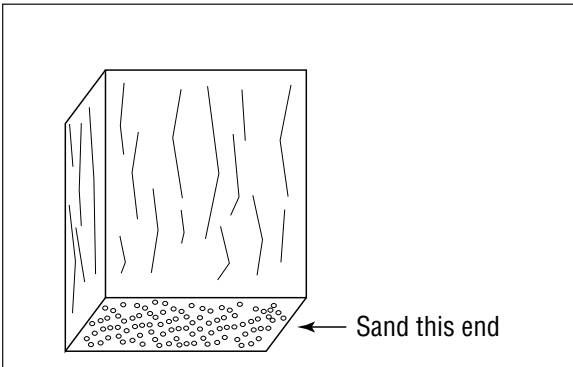
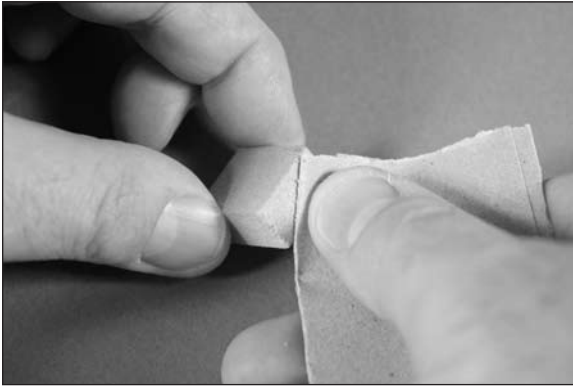

□□ 7. Use 30-minute epoxy to glue the 10mm x 17mm x 20mm hardwood blocks to the servo cover. Allow the epoxy to fully cure before proceeding.

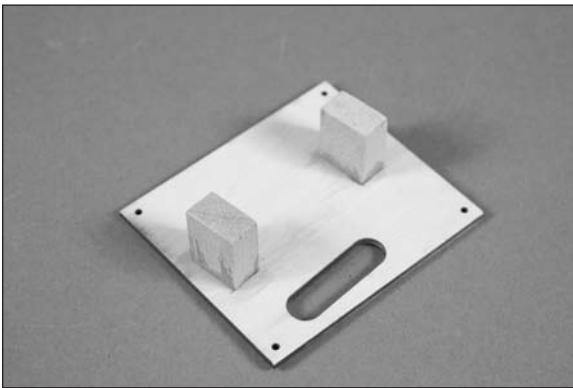

□□ 8. Position the aileron servo between the mounting blocks. Space the servo so it is not resting directly on the servo cover as this will cause vibrations from the airframe to be transferred to the servo. Use a pencil to mark the location for the screws that will secure the servo to the mounting blocks.



□□ 9. Use a drill and 1/16-inch (1.5mm) drill bit to drill the holes for the four mounting screws.

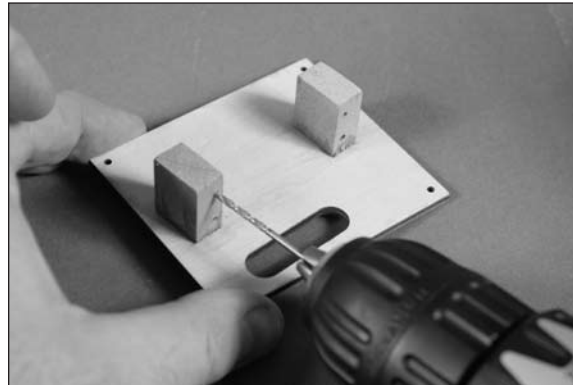

□□ 10. Use a #1 Phillips screwdriver to run a servo mounting screw in each of the four holes. Make sure to remove the screw before proceeding to the next step.

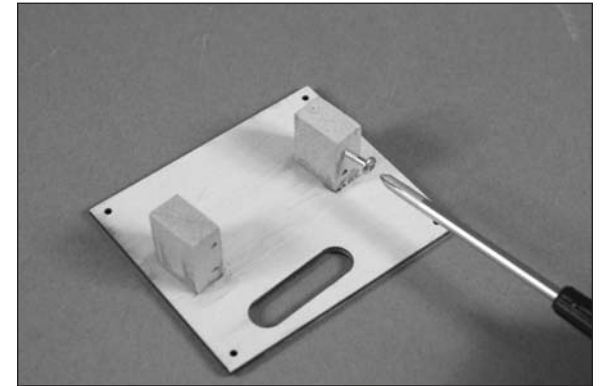

□□ 11. Apply 2-3 drops of thin CA in each hole drilled. This will harden the surrounding wood, making the screws more secure when installed.

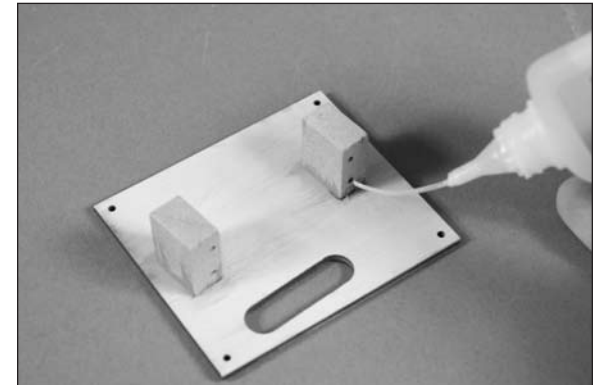

**Important:** Do not use a CA accelerator. Using an accelerator will not allow the CA to soak into the fibers of the wood, hardening the blocks.

□□ 12. Use the screws provided with the servo and a #1 Phillips screwdriver to attach the servo to the mounting blocks.

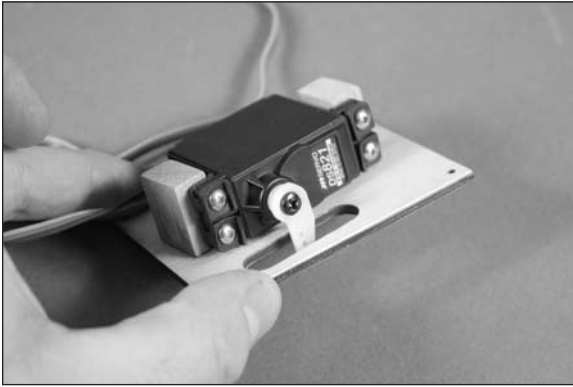

□□ 13. Secure a 12-inch (305mm) servo extension to the aileron servo lead using string or a commercially available connector. Use tape to temporarily attach the extension if you are installing the optional retracts.

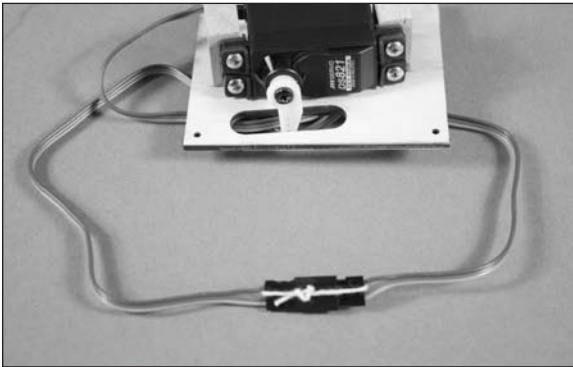

□□ 14. Use a T-pin to poke the covering in the locations for the four servo cover mounting screws.

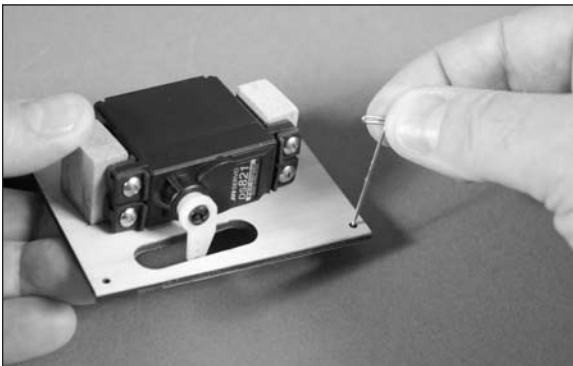

□□ 15. Tie the string inside the wing to the end of the extension. The string will be used to pull the extension through the wing.

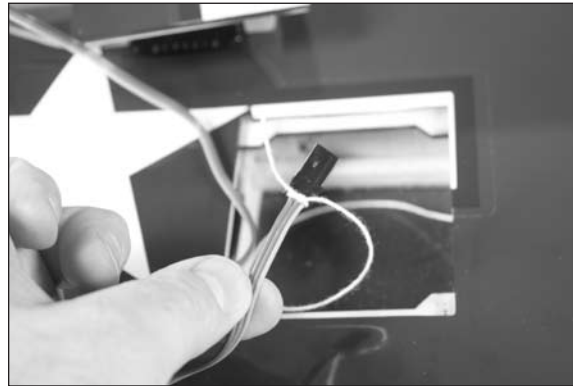

□□ 16. Carefully pull the extension through the wing. The servo cover can then be placed into position on the wing.

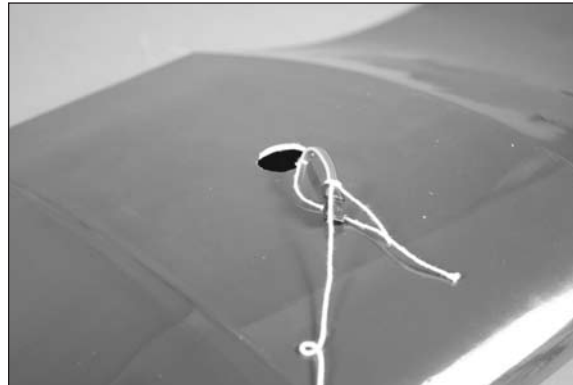

**Note:** Place the drill bit in the drill chuck as far as possible to help prevent accidentally drilling through the top of the wing accidentally.

□□ 17. Use a drill and 1/16-inch (1.5mm) drill bit to drill the four holes for the servo cover mounting screws.



□□ 18. Use a #1 Phillips screwdriver to run a 2mm x 10mm black washer head screw in each of the four holes. Make sure to remove the screw before proceeding to the next step.

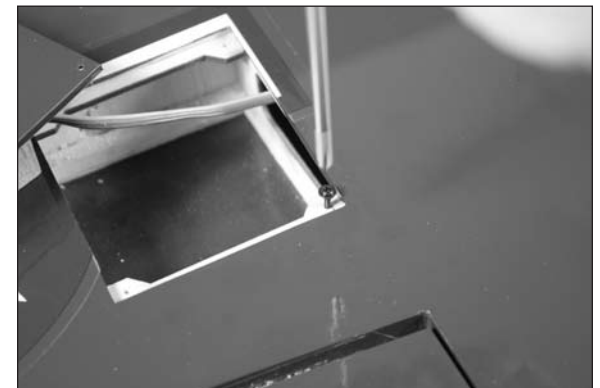

□□ 19. Apply 2–3 drops of thin CA in each of the holes that will accept the servo cover mounting screws.

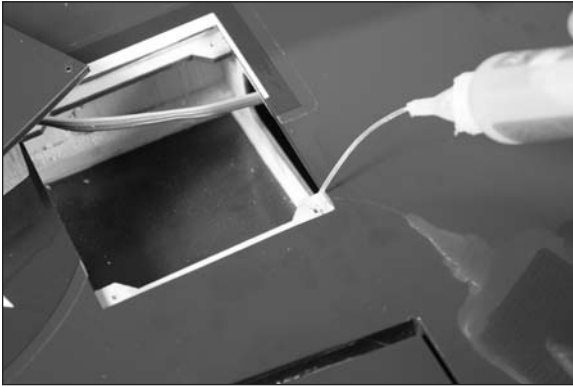

□□ 20. Use four 2mm x 10mm black washer head screws and a #1 Phillips screwdriver to secure the cover to the wing.

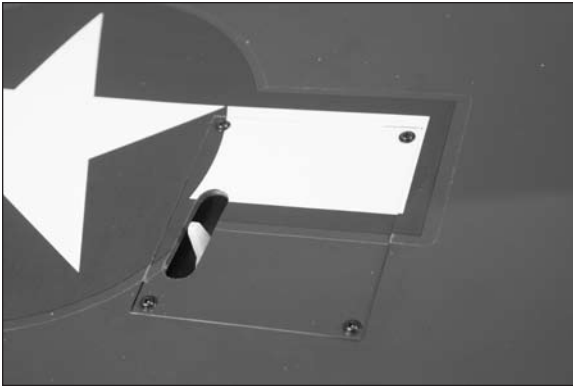

□□ 21. Repeat Steps 2 through 20 to install the remaining aileron servo. Make sure you install the servo so you have a right and left servo installation.

## Aileron Linkage Installation

### Required Parts

Assembled wing	Nylon clevis (2)
Safety tubing	2mm x 53mm pushrod (2)
Transmitter	Receiver
Receiver battery	2mm x 10mm wood screw (6)
Control horn with backplate (2)	

### Required Tools and Adhesives

Thin CA	Phillips screwdriver: #1
Ruler	Felt-tipped pen
Low-tack tape	Drill
Hobby knife with #11 blade	
Drill bit: 1/16-inch (1.5mm)	

□ 1. Locate the hardware to install the aileron linkages. The wing assembly is also required for this section of the manual.

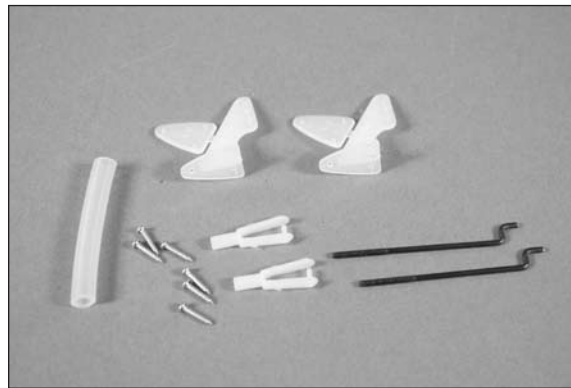

□□ 2. Use a ruler and a felt-tipped pen to make a small mark on the aileron used for positioning the aileron control horn. Align the ruler so it is resting against the outside edge of the servo horn and is 90-degrees to the aileron hinge line.

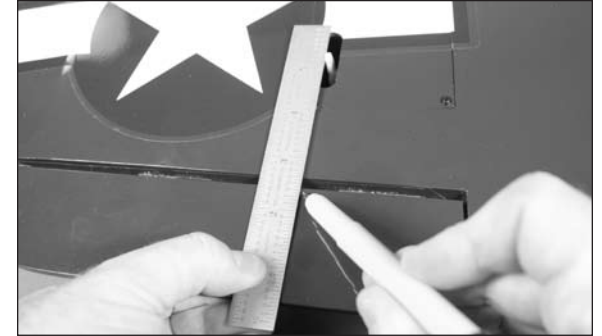

□□ 3. Use a hobby knife with a #11 blade to remove the backplate from the control horn. Center the control horn on the mark made in the previous step. Set the front edge of the horn back 1/8-inch (3mm) from the edge of the bevel to guarantee the horn is positioned on the hardwood block located in the aileron. Use a felt-tipped pen to mark the locations for the two mounting screws on the aileron.

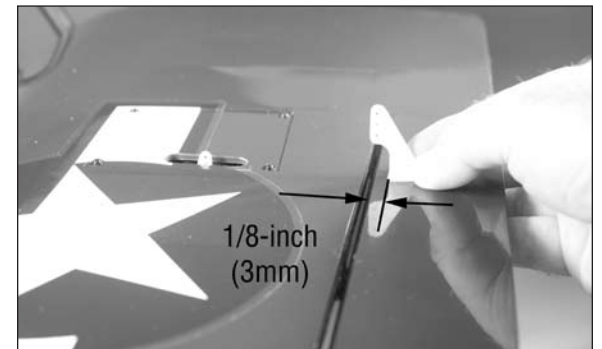

□□ 4. Place a 1/16-inch (1.5mm) drill bit in the drill. Wrap a piece of tape around the drill bit 5/16-inch (8mm) from the end of the drill bit to prevent accidentally drilling through the top of the aileron.

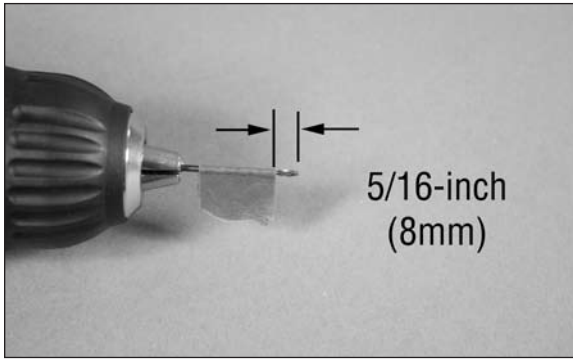

□□ 5. Use a drill and a 1/16-inch (1.5mm) drill bit to drill the holes for the control horn mounting screws.

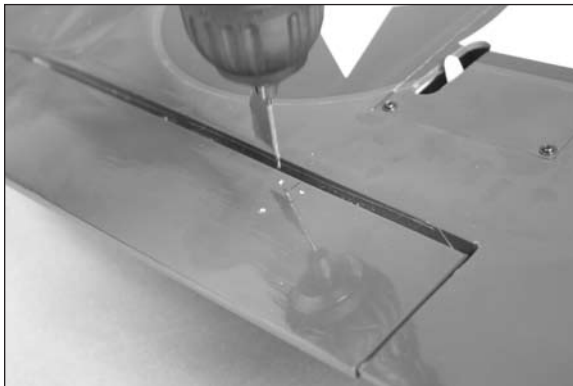

□□ 6. Use a #1 Phillips screwdriver to run a 2mm x 10mm wood screw in each of the holes. Make sure to remove the screw before proceeding to the next step.



□□ 7. Apply 2–3 drops of thin CA in each of the holes that will accept the servo cover mounting screws.

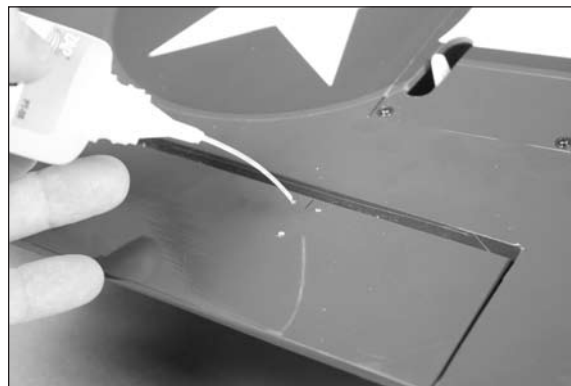

□□ 8. Use three 2mm x 10mm wood screws to secure the control horn to the aileron. Use a #1 Phillips screwdriver to tighten the screws. Be careful not to crush the underlying wood when installing the control horn.

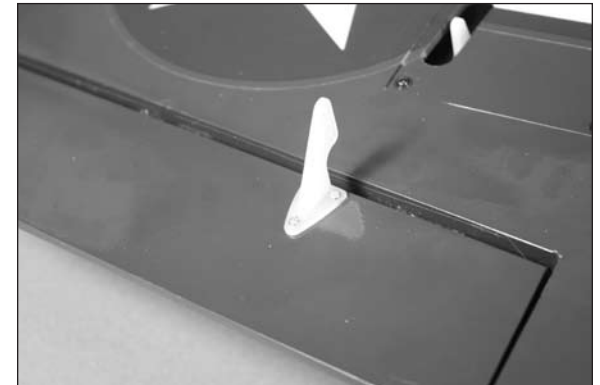

□□ 9. Insert the Z-bend of the 2mm x 53mm linkage in the hole of the servo arm that was enlarged in the previous section of this manual.

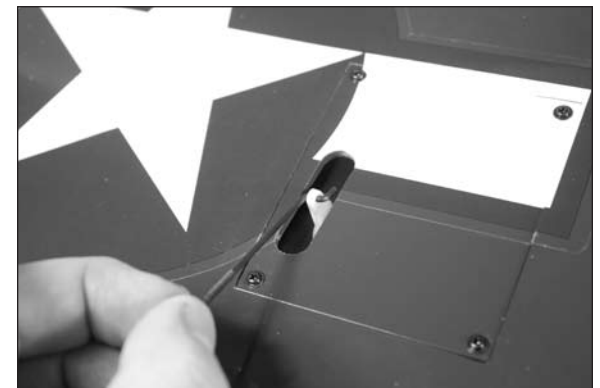

10. Use a hobby knife with a #11 blade to cut a 1/4-inch (6mm) piece from the safety tubing.

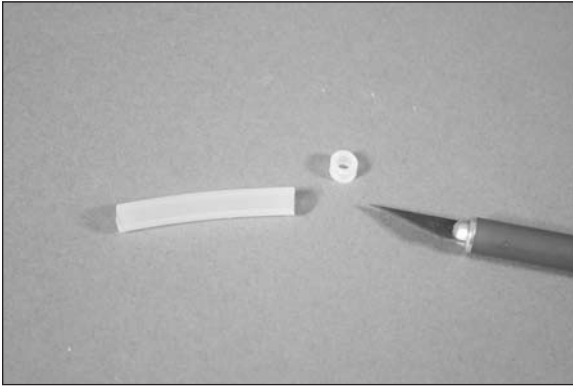

11. Slide the safety tubing on the nylon clevis. Turn on the radio system and center the aileron stick and trim. This will center the aileron servo. Thread the nylon clevis on the pushrod. Thread the clevis on enough so the aileron is centered when the clevis is connected to the center hole of the control horn shown below. Once set, slide the safety tubing over the forks of the clevis to keep the clevis from opening accidentally.

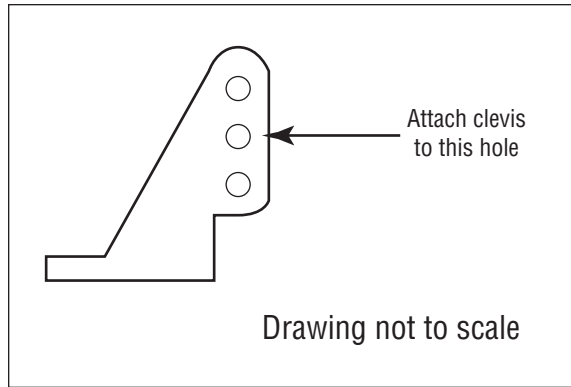
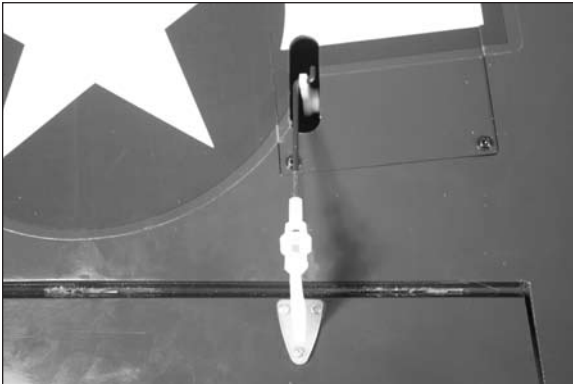

12. Check the operation of the aileron using the radio system. If you find the pushrod or servo horn binding on the servo cover, use a hobby knife with a #11 blade to slightly trim the cover to eliminate this binding.

13. Repeat steps 1 through 12 to install the remaining aileron control horn and linkage.

14. Remember to turn off the radio system at this time to avoid running the batteries down.

## ***Fixed Main Landing Gear Installation***

### **Required Parts**

Assembled wing	3 1/2-inch (89mm) wheel (2)
Metal bracket (2)	2mm washer (4)
2mm nut (4)	2mm plywood door, blue (2)
Main landing gear (right and left)	
4mm wheel collar with setscrew (4)	
2mm x 10mm machine screw (4)	
3mm x 15mm counter sunk screw, black (4)	
3mm x 20mm counter sunk screw, black (4)	

### **Required Tools and Adhesives**

Low-tack tape	Light machine oil
Flat file	Hobby knife with #11 blade
Ruler	Phillips screwdriver: #1, #2
Pencil	Drill
Nut driver: 4mm	Thin CA
Silicone adhesive	
Drill bit: 5/64-inch (2mm)	T-pin
Hex wrench: 1.5mm (included)	

**Note:** Skip to the following section “Retract Installation” if you are planning on installing the optional retracts in your model.

1. Locate the hardware to install the fixed main landing gear. The wing assembly is also required for this section of the manual.

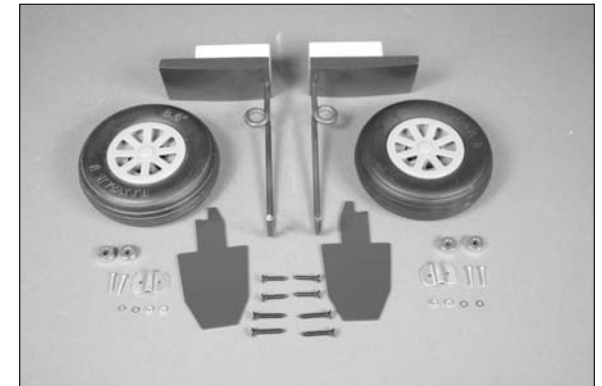

□□ 2. Use a flat file to file two 1/4-inch (6mm) wide flat spots on the main landing gear. The first is located at the end of the wire, the second is centered 3/4-inch (19mm) from the end of the axle. Make the flat on the bottom so it can be accessed when the landing gear has been attached to the wing.

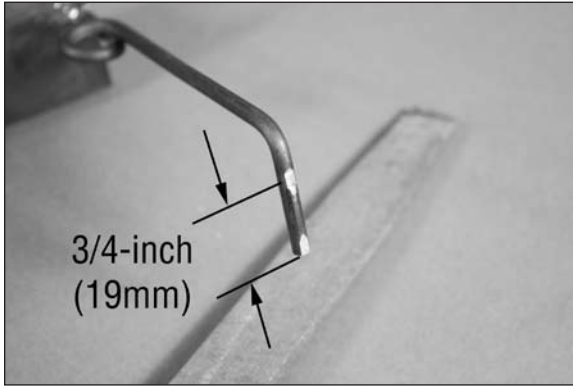

□□ 3. Use a hobby knife with a #11 blade to remove the covering from the mounting holes in the main landing gear.

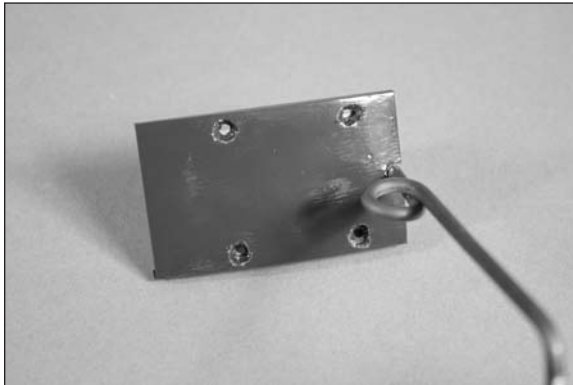

□□ 4. Test fit the main gear into the wing. There is a left and right, and the mounting plate will match the contour of the wing when installed.

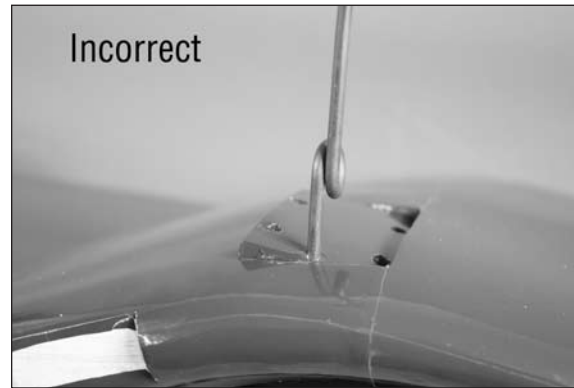

□□ 5. Use a pencil to transfer the locations for the mounting screws onto the landing gear rails inside the wing.

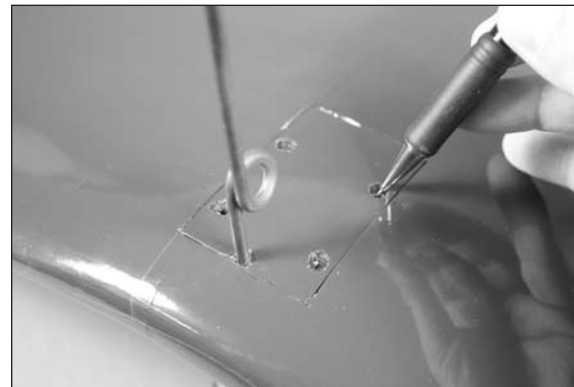

□□ 6. Place a 5/64-inch (2mm) drill bit in the drill. Wrap a piece of tape around the drill bit 3/4-inch (19mm) from the end of the drill bit to prevent accidentally drilling through the top of the wing.

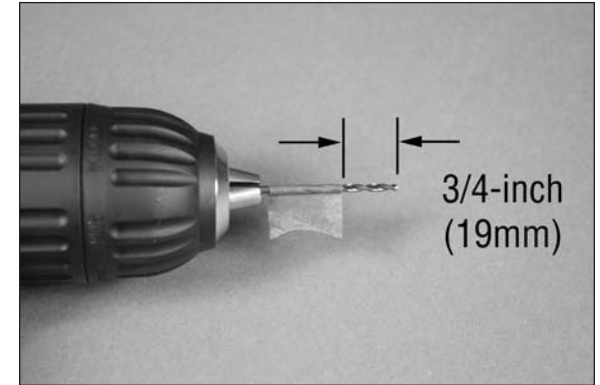

□□ 7. Drill the holes in the landing gear rails for the landing gear mounting screws.





□□ 8. Use a #2 Phillips screwdriver to thread a 3mm x 15mm black counter sunk screw into each of the four holes drilled in the previous step. This will cut threads into the surrounding wood. Remove the screw before proceeding to the next step.

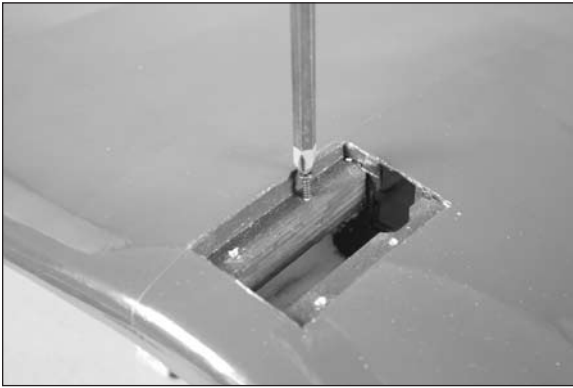

□□ 9. Apply 2–3 drops of thin CA in each of the holes to harden the surrounding wood. This will make the screws more secure and help prevent them from vibrating loose.

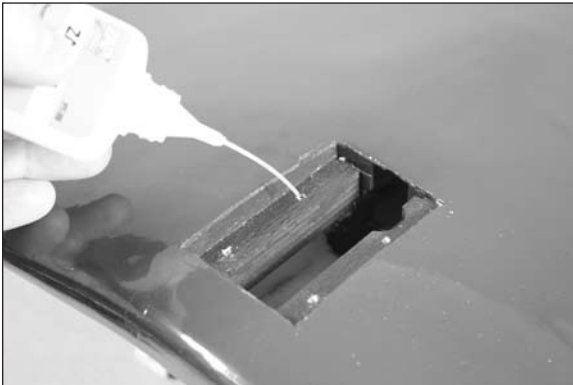

□□ 10. Attach the main landing gear using two 3mm x 15mm black counter sunk screws and two 3mm x 20mm black counter sunk screws. The longer screws are using on the thicker side of the main gear as shown. Use a #2 Phillips screwdriver to tighten the screws.

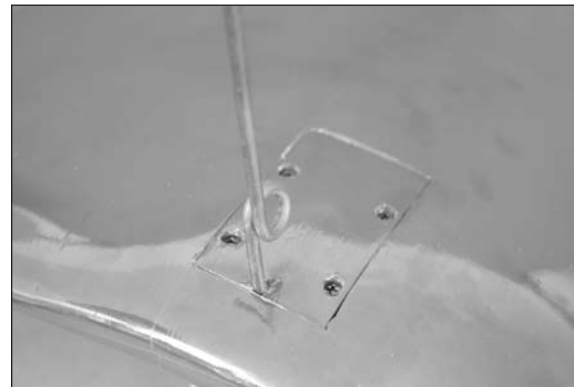
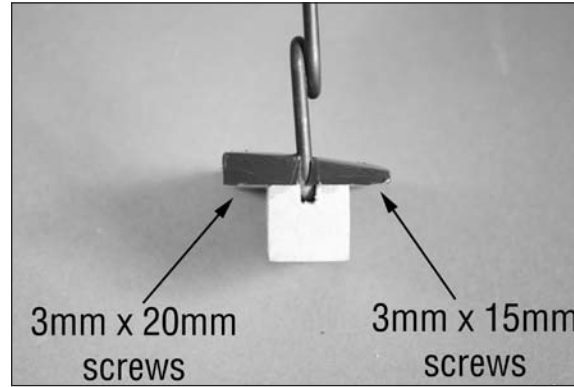

□□ 11. Slide a 4mm wheel collar onto the landing gear wire. Do not tighten the setscrew at this time.



□□ 12. Place a drop of light machine oil on the axle.



□□ 13. Remove the hub cap from the main wheel. Slide the wheel on the landing gear wire with the side of the wheel that had the hub cap toward the wing tip.



**Note:** Always use threadlock on metal-to-metal fasteners to prevent them from vibrating loose.

- 14. Attach the wheel collar to the axle to keep the wheel on the gear. The edge of the wheel collar will be flush with the end of the axle. Use a 1.5mm hex wrench (included) to tighten the setscrew.



- 15. Slide the wheel collar installed in step 10 against the wheel, but not so tight as it prevents the wheel from rotating smoothly. Use a 1.5mm hex wrench (included) to tighten the setscrew. Remember to use threadlock on the setscrew to prevent it from vibrating loose.



- 16. Snap the hub cap back into position on the wheel.



- 17. Use a T-pin to poke through the covering on the gear door for the mounting screws.

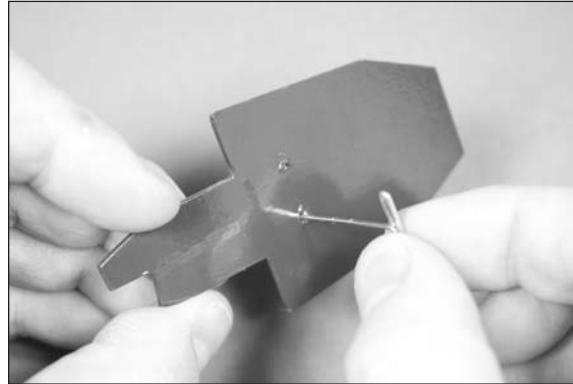

**Note:** Always use threadlock on metal-to-metal fasteners to prevent them from vibrating loose.

- 18. Attach the main gear door to the landing gear using two 2mm x 10mm machine screws, two 2mm washers, two 2mm nuts and a metal bracket. Use a #1 Phillips screwdriver and a 4mm nut driver to tighten the hardware.

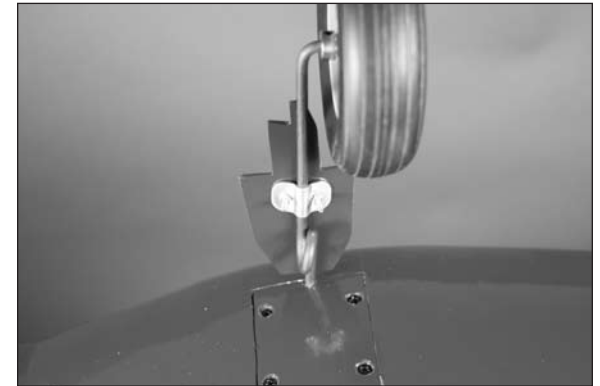
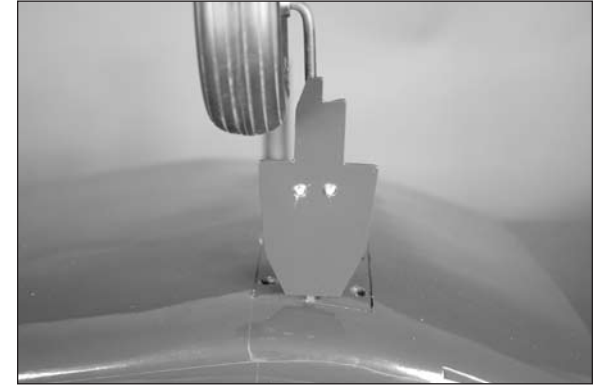

**Hint:** Apply a small amount of silicone adhesive between the gear door and strut wire to prevent it from rotating in flight.

- 19. Repeat steps 2 through 17 to install the remaining landing gear assembly and wheel.

## Retract Installation

### Required Parts (included with kit)

Assembled wing	3½-inch (89mm) wheel (2)
Transmitter	Receiver
Receiver battery	
Wheel well, blue (right and left)	
4mm wheel collar with setscrew (2)	
Wheel well template, clear (right and left)	

### Required Parts (included with retracts)

Retract assembly with strut (right and left)	
Y-harness	4mm x 30mm axle (2)
4mm wheel collar with setscrew (4)	

### Required Parts (not included)

#4 x 3/4-inch sheet metal screw (8)

### Required Tools and Adhesives

Rotary tool	Cutoff wheel
Sanding drum	Light machine oil
Flat file	Hobby knife with #11 blade
Ruler	Phillips screwdriver: #1, #2
Pencil	Drill
Low-tack tape	Drill bit: 5/64-inch (2mm)
Thin CA	Canopy glue
Hobby scissors	Felt-tipped pen
String or dental floss	
Hex wrench: 1.5mm (included), 2.5mm	

**Note:** If you have installed fixed gear, skip to the next section "Wing Installation."

□ 1. Locate the hardware to install the retracts. The wing assembly is also required for this section of the manual.



□□ 2. Use the radio system to extend the retracts to the open position. Use a rotary tool and cutoff wheel to trim the retract strut length to 4⅛ inches (105mm) from the top of the wheel collar. Use a flat file to remove any burrs after trimming the strut length.

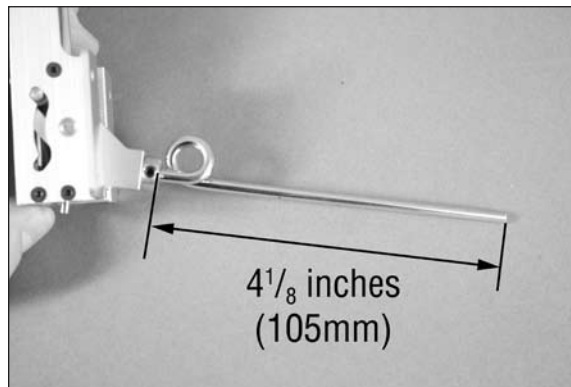

□□ 3. With the retract in the up position, place the retract in the wing. Carefully trim the wing sheeting to allow the strut to fit inside the wing. The slot must be wide enough to allow the retract to operate without it hitting the sheeting.

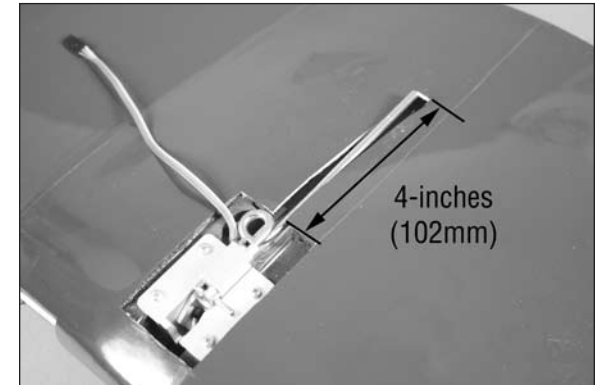

□□ 4. With the retract centered in the mount, use a pencil to mark the front of the retract opening for the notch needed to allow the rotational pin to clear.

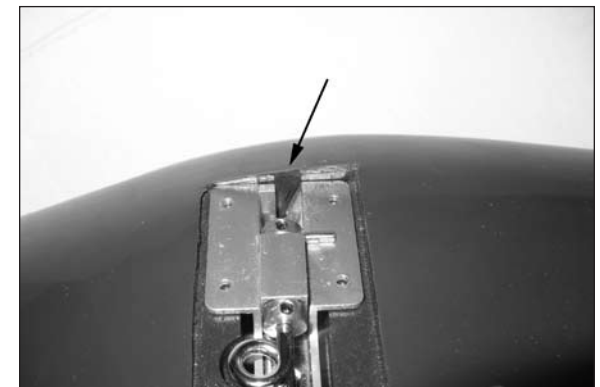

□□ 5. Using a rotary tool and bit grind out a slot, avoid cutting into the top sheeting. Check that there will be adequate clearance for the pin when the retract is installed.



□□ 6. Remove the retract from the wing. Use the radio system to cycle the retract to the down position. Place the retract in the wing. Center the retract frame on the rails, and make sure the retract motor is parallel to the rails. Use a pencil to mark the location for the four mounting screws through the retract frame and onto the rails.



□□ 7. Place a 5/64-inch (2mm) drill bit in the drill. Wrap a piece of tape around the drill bit 3/4-inch (19mm) from the end of the drill bit to prevent accidentally drilling through the top of the wing.

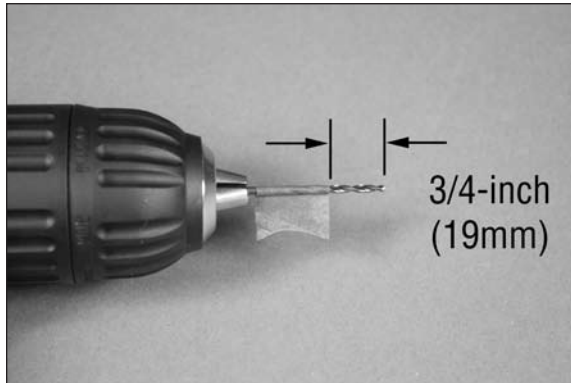

□□ 8. Drill the holes in the landing gear rails for the landing gear mounting screws.



□□ 9. Use a #2 Phillips screwdriver to thread a #4 x 3/4-inch sheet metal screw into each of the four holes drilled in the previous step. This will cut threads into the surrounding wood. Remove the screw before proceeding to the next step.

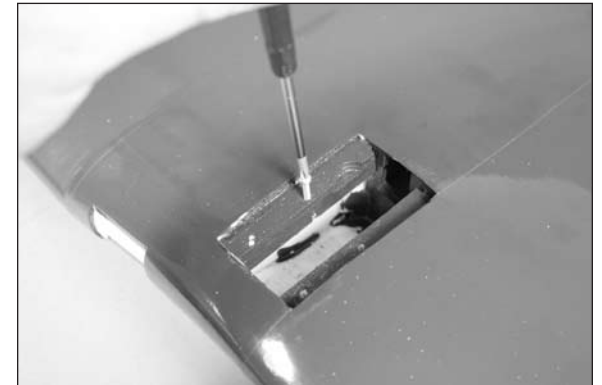

□□ 10. Apply 2–3 drops of thin CA in each of the holes to harden the surrounding wood. This will make the screws more secure and help prevent them from vibrating loose.

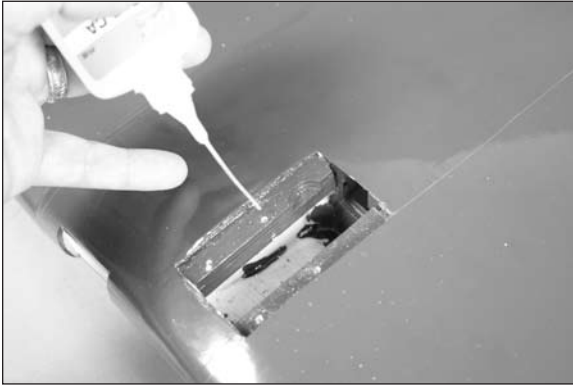

□□ 11. Secure the retract in the wing using four #4 x 3/4-inch sheet metal screws. Use a #1 or #2 Phillips screwdriver to tighten the screws. Leave the lead for the retract out so it can be easily accessed for the following steps.

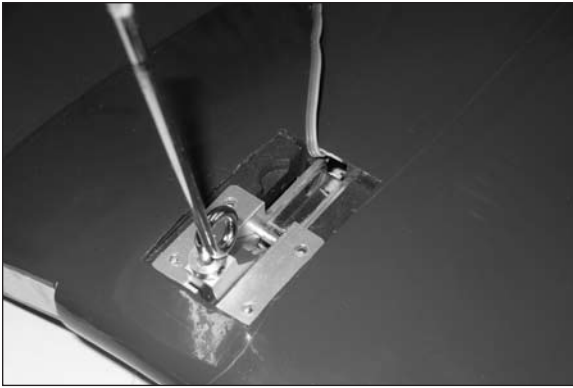

□□ 12. Use a hobby knife with a #11 blade and hobby scissors to trim the clear plastic template. Note that the right and left templates are referenced as if you were the pilot.

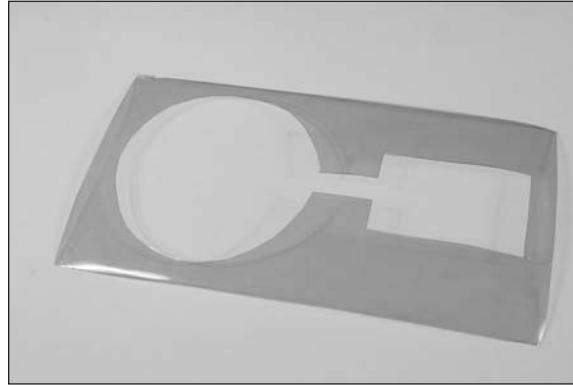

□□ 13. Use low-tack tape to secure the template to the bottom of the wing. Check that the rear edge for the wheel well opening is  $2^{13}/_{16}$ -inch (71mm) forward of the trailing edge of the wing. Also use a ruler to make sure the template is centered in relationship to the retract strut.

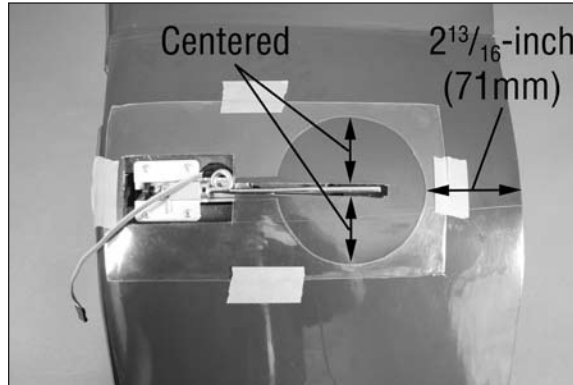

□□ 14. Use a felt-tipped pen to trace the outline for the wheel well onto the bottom of the wing.

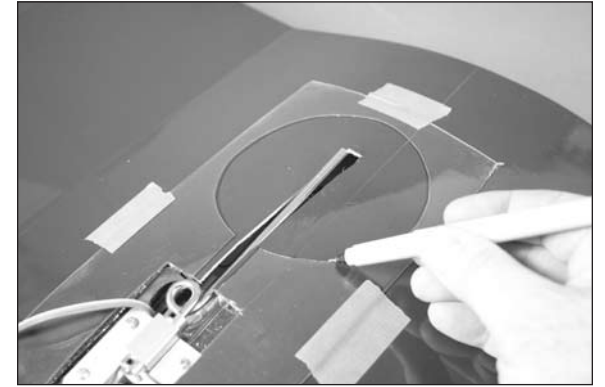

□□ 15. Use a hobby knife with a new #11 blade to carefully trim the opening for the wheel well in the bottom of the wing. Work slowly to avoid any mistakes.

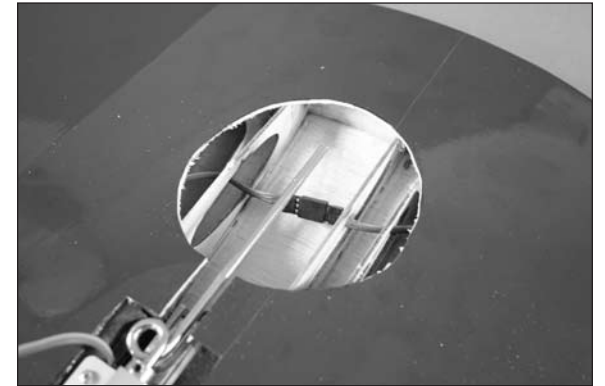

□□ 16. Use a hobby knife and #11 blade to remove the rib sections from inside the wing to allow the installation of the wheel well. The ribs have been laser cut to aid in their removal.

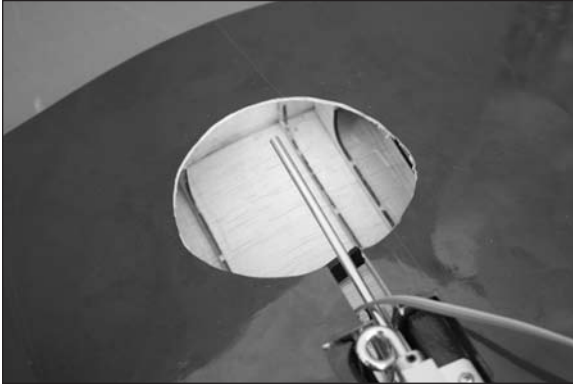

□□ 17. Install the Y-harness included with the retracts and secure it to the lead on the retract using string or dental floss. There are openings in the ribs near the spar to route the aileron and retract servo leads. This will keep the leads from interfering with the fit of the wheel well. Remove the temporary tape from the aileron connection to allow both the retract and aileron extensions to be routed through the wing, as shown in the photo on the following page.

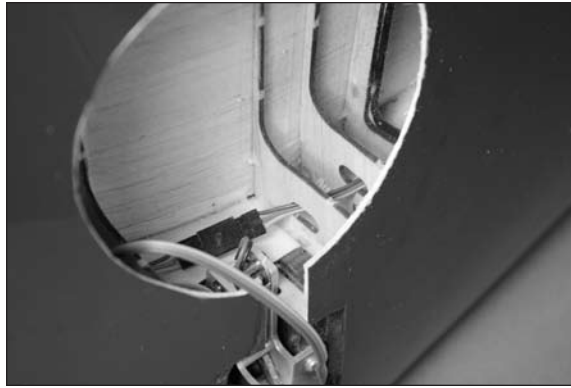
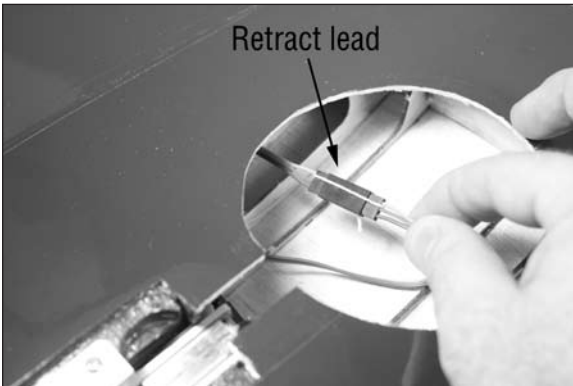

□□ 18. Check the fit of the wheel well into the wing. You may need to use a rotary tool and sanding drum to adjust the opening to allow the well to fit. It may also be necessary to notch the wheel well to clear the top of the retract chassis. Use low-tack tape to hold the wheel well in position. Do not glue the wheel well at this time.

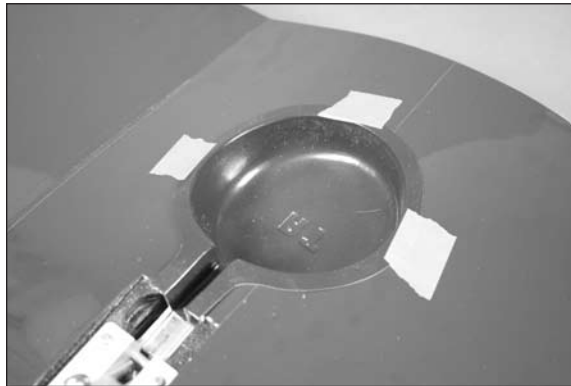

**Note:** You may be necessary to lightly sand a couple of the wing ribs next to the wing sheeting to allow the wheel well lip to fit flush to the wing surface.

**Note:** Always use threadlock on metal-to-metal fasteners to prevent them from vibrating loose. Since the collar is being used as a spacer, you will not need a flat for the setscrew on this particular wheel collar.

□□ 19. Slide the 4mm wheel collar included with the retracts (this collar has a dull finish) on the axle from the retract. Use the setscrew to secure the collar on the axle.



□□ 20. Remove the hub cap from the main wheel. Slide the wheel on the axle with the side opposite the hub cap facing the wheel collar.



□□ 21. Slide the wheel collar from the kit (this collar has a chrome finish) onto the axle. With the axle pressed against the backside of the wheel, use a felt-tipped pen to mark the axle at the edge of the wheel collar.



□□ 22. Remove the wheel and wheel collar from the axle. Use a rotary tool and cutoff wheel to trim the length of the axle at the mark made in the previous step. Use a flat file to remove any burrs left from trimming the axle.



□□ 23. Use a flat file to make a 1/4-inch (6mm) wide flat at the end of the axle.

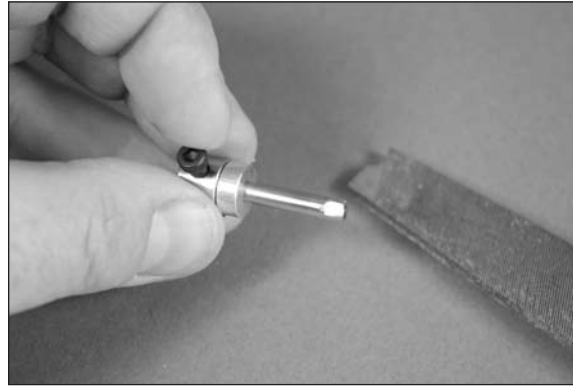

□□ 24. Place a drop of light machine oil on the axle so the wheel will rotate freely on the axle.

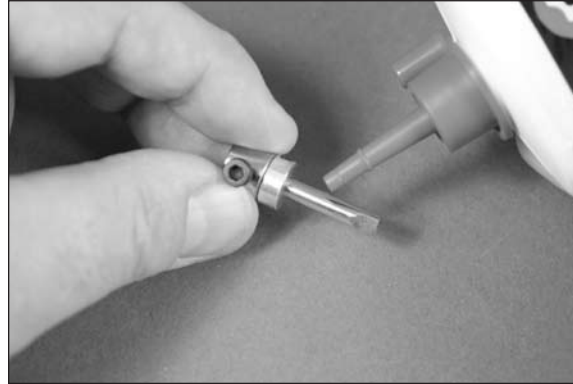

**Note:** Always use threadlock on metal-to-metal fasteners to prevent them from vibrating loose.

□□ 25. Slide the wheel and wheel collar on the axle. Use a 1.5mm hex wrench to tighten the setscrew onto the flat made in step 22.



**Note:** If you choose to use a 1.5mm ball driver to tighten the setscrew make a small notch in the wheel hub to reduce the angle of the hex wrench so it fits the setscrew better and to reduce the chance of stripping the setscrew.

□□ 26. Snap the hub cap back into position on the wheel.



□□ 27. With the retract in the down position, slide the axle on the landing gear wire. Note that the wheel faces toward the wing tip as shown in the following step. Use the radio to move the gear to the up position while guiding the wheel into the wheel well. Use a 2.5mm hex wrench to tighten the two screws that secure the axle to the main gear wire. Only tighten the screws enough so the wheel won't change position when the retract is in motion.

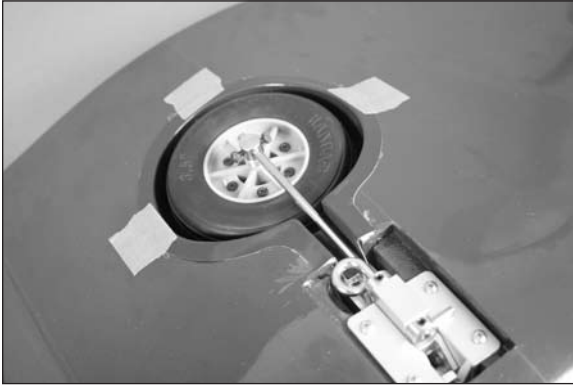

□□ 28. Use the radio to move the gear to the down position. Check that the wheel has a very slight amount of toe-in (front of wheels slightly closer to the wing centerline) in relationship to the wing centerline. This will make take-off much easier. Cycle the retract a few times and adjust the position of the wheel on the axle and the wheel well if necessary so they do not contact each other while operating the retracts.

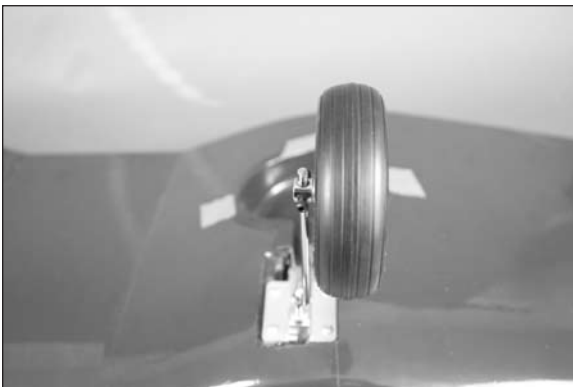

**Note:** Always use threadlock on metal-to-metal fasteners to prevent them from vibrating loose.

□□ 29. Tighten the screws on the axle so they leave indentations on the wire strut. Remove the axle then use a flat file to make flat areas for the screws so the axle does not rotate on the gear wire. Replace the axle and tighten the screws using a 2.5mm hex wrench.

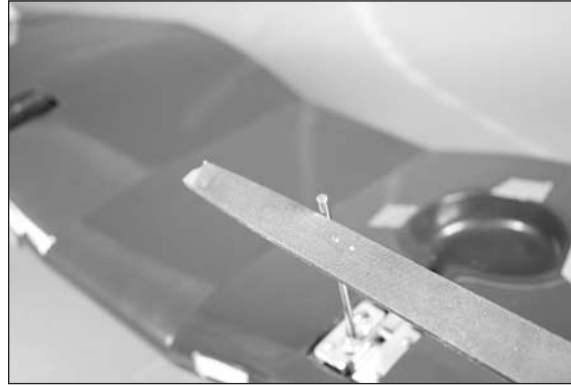

□□ 30. Use a felt-tipped pen to trace around the wheel well.



□□ 31. Use a hobby knife with a new #11 blade to remove the covering 5/64-inch (2mm) inside the line so the wheel well can be glued to the exposed wood.

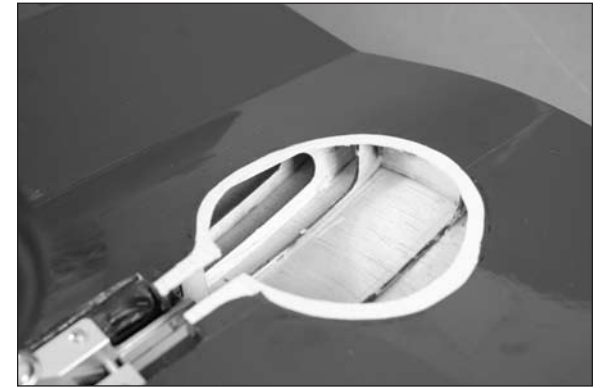

**Note:** Make sure to use a new #11 blade and use light pressure to trim only the covering. Avoid cutting into the underlying wood, which could weaken the structure of your model.

□□ 32. Use canopy glue to secure the wheel well in the wing. Use low-tack tape to hold the wheel well in position until the glue fully cures. See photo at step 26.

**Note:** It may be necessary to use a rotary tool and cut-off wheel to trim the length of the landing gear closer to the axle once installed.

□□ 33. Repeat steps 2 through 32 to install the remaining retract assembly and wheel.

**Note:** When installing the remaining retract, make sure to measure the position of the axle on the current retract to match the length of the struts exactly.



## Wing Installation

### Required Parts

Assembled wing	Fuselage
Fiberglass belly pan	6mm x 30mm dowel (2)
3mm plywood doubler	8-32 blind nut (2)
#8 washer (2)	
8-32 x 1 <sup>1</sup> / <sub>4</sub> -inch socket head cap screw (2)	

### Required Tools and Adhesives

30-minute epoxy	Mixing stick
Mixing cup	Epoxy brush
Felt-tipped pen	Hobby knife with #11 blade
Low-tack tape	C-clamp
Hex wrench: 9/64-inch	Waxed paper

□ 1. Locate the items to install the wing on the fuselage. The wing assembly and fuselage will also be required for this section of the manual.

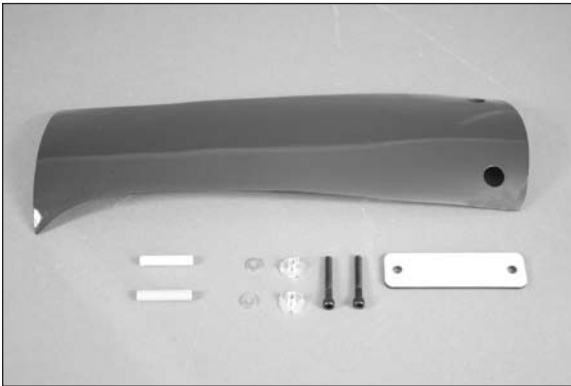

□ 2. Use a hobby knife with a #11 blade to remove the covering at the leading edge for the wing dowels. Also remove the covering at the trailing edge for the wing bolts.

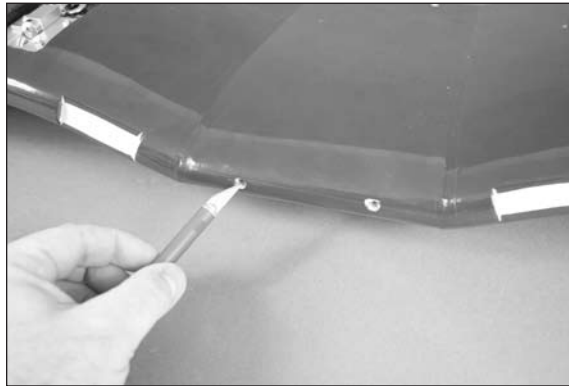

□ 3. Use 30-minute epoxy to glue the two 6mm x 30mm dowels in the leading edge of the wing. Make sure the dowels are positioned so 3/8-inch (10mm) of the dowel is exposed forward of the leading edge as shown.

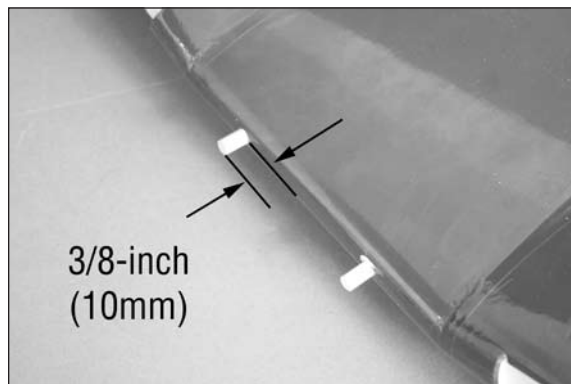

□ 4. Position the 3mm plywood doubler on the trailing edge of the wing, aligning the holes in the doubler with the holes in the wing. Use a felt-tipped pen to trace the outline of the doubler on the wing.

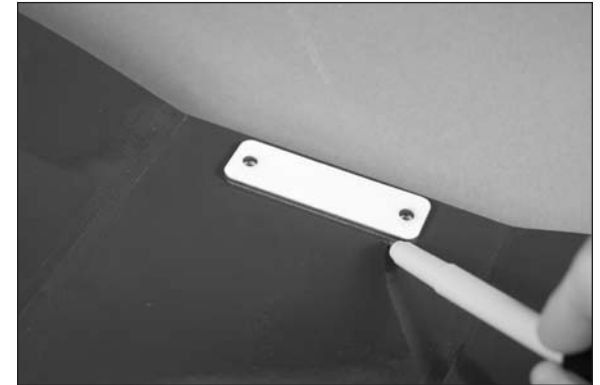

□ 5. Use a hobby knife and a #11 blade to trim the covering 1/16-inch (1.5mm) inside the line drawn on the previous step. Remove the covering from the bottom of the wing.

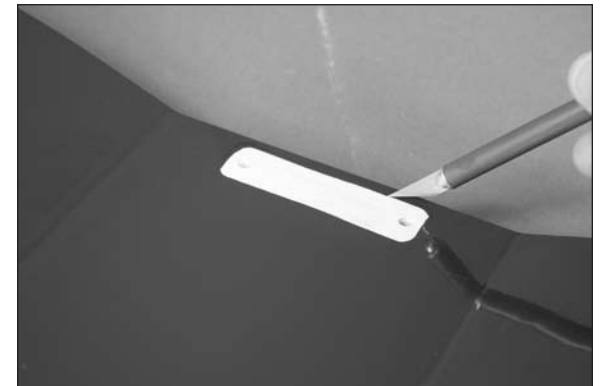

**Note:** Make sure to use a new #11 blade and use light pressure to trim only the covering. Avoid cutting into the underlying wood, which could weaken the structure of your model.

- 6. Use 30-minute epoxy to glue the doubler to the bottom of the wing. Use tape to hold the doubler in alignment with the wing bolt holes until the epoxy fully cures.

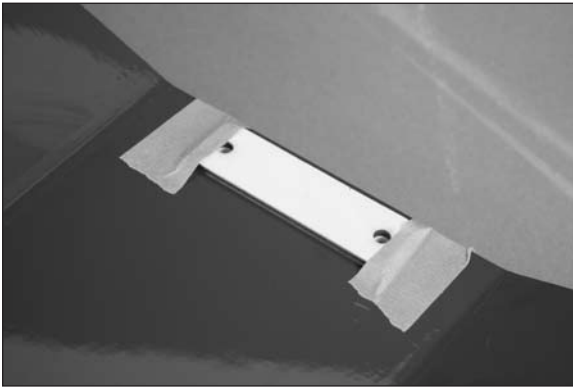

- 7. Use a small C-clamp to press the two 8-32 blind nuts into position from the inside of the fuselage. Use a small amount of 30-minute epoxy to each of the prongs to secure the blind nut in the wood. Use care not to get any epoxy into the threads of the blind nut.



**Hint:** Use a mixing stick between the plate and clamp to protect the plate while tightening the clamp.

- 8. Use a hobby knife and a #11 blade to remove the covering from the fuselage to expose the holes for the wing dowels. Tape a piece of waxed paper at the front and rear of the wing saddle. Attach the wing to the fuselage using two 8-32 x 1 $\frac{1}{4}$ -inch socket head cap screws and two #8 washers. Use a 9/64-inch hex wrench to tighten the screws.



- 9. Position the fiberglass belly pan on the bottom of the fuselage, aligning it with the contour of the fuselage. Use a felt-tipped pen to trace the outline of the belly pan onto the wing.



**Hint:** The fiberglass belly pan may not lay flat against the wing. Use a washcloth soaked in hot water to warm the fiberglass, making it pliable so you can mold it to the wing contour.

- 10. Set the belly pan aside and use a hobby knife with a #11 blade to trim a 1/4-inch (6mm) wide strip of covering 1/16-inch (1.5mm) inside the outline of the belly pan on the bottom of the wing.



**Note:** Make sure to use a new #11 blade and use light pressure to trim only the covering. Avoid cutting into the underlying wood, which could weaken the structure of your model.

- 11. Apply low-tack tape outside the line drawn in step 9. This will help prevent epoxy from getting all over the wing when gluing the belly pan into position.



□ 12. Mix 1/2 ounce (15mL) of 30-minute epoxy. Use an epoxy brush to coat the exposed wood on the bottom of the wing. You will want a nice build-up of epoxy to guarantee that it fully contacts the belly pan.



□ 13. Place the belly pan into position on the bottom of the wing. Use low-tack tape to hold the belly pan in position.

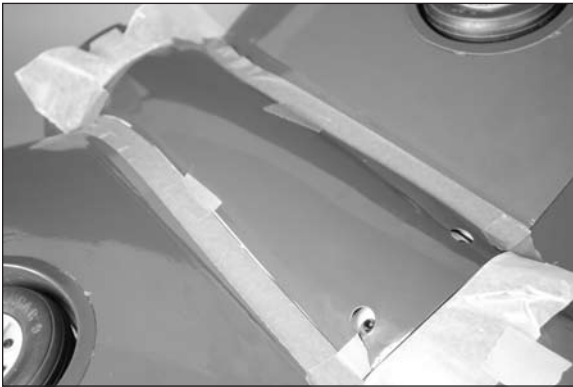

□ 13. After around 25 minutes, before the epoxy fully cures, carefully remove the tape from around the belly pan. Pull the tape away from the wing, being careful not to disturb the position of the belly pan. This will allow the epoxy to flow out slightly, leaving a fillet between the belly pan and wing. Allow the epoxy to fully cure before disturbing the airframe.



□ 14. Remove the waxed paper from the fuselage to complete the belly pan installation. Leave the wing attached to the fuselage so the stabilizer can be installed.

## Stabilizer and Elevator Installation

### Required Parts

Assembled wing	Fuselage
Stabilizer	Elevator (2)
CA hinge (6)	3mm metal joiner rod

### Required Tools and Adhesives

30-minute epoxy	Epoxy brush
Toothpick	Hobby knife with #11 blade
Waxed paper	Low-tack tape
Ruler	T-pins
Medium grit sandpaper	Thin CA
Hex wrench: 9/64-inch	Tape measure
Pin vise	Drill bit: 1/16-inch (1.5mm)
Paper towels	Denatured alcohol

□ 1. Locate the stabilizer, elevator and metal joiner rod. You will also need the wing and fuselage for the installation of the elevator and stabilizer.

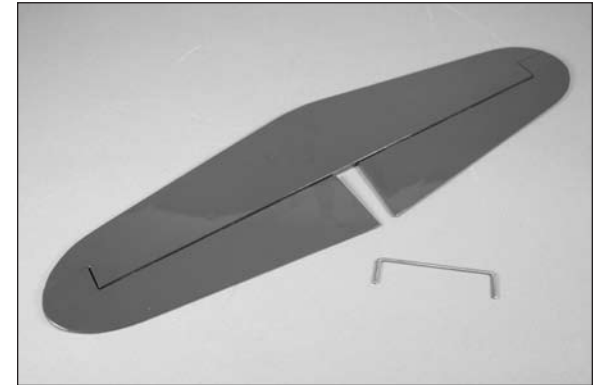

- 2. Separate the elevators from the stabilizer. Set the elevators and six CA hinges aside.

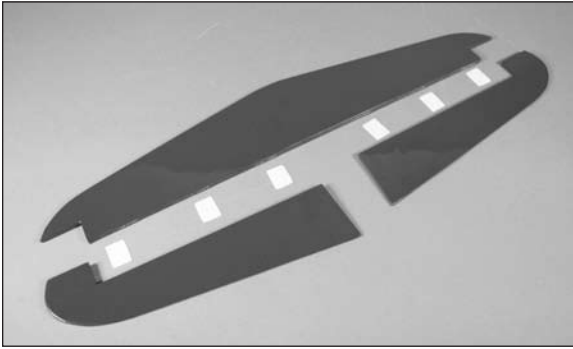

- 3. Determine the top and bottom of the stabilizer by inspecting the covering seam. The top covering overlaps down, around and over the bottom covering. Slide the stabilizer into the slot in the fuselage with the stabilizer as far forward in the slot as possible, measure from the fuselage to each tip. Center the stabilizer so the measurements are the same.

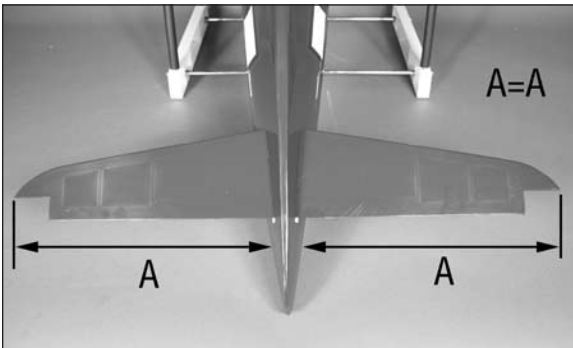

- 6. Measure from stabilizer tip to the wing tip on both the left and right side of the airframe. The measurement must match exactly to align the stabilizer with the wing.

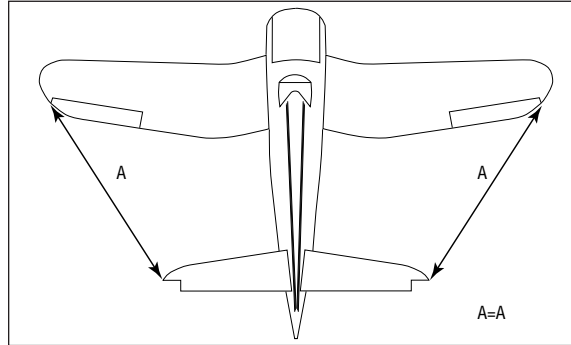

- 7. Stand back 8–10 feet (2–3 meters) and view the aircraft from the rear. The wing and stabilizer must be an equal distance from each other to be in alignment. If not, use medium grit sandpaper to lightly sand the opening in the fuselage to correct any alignment issues.

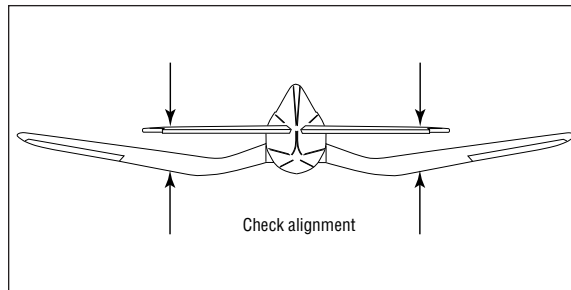

- 8. Double check the alignment of the stabilizer as described in steps 5 through 7. Once set, use a felt-tipped pen to trace the outline of the fuselage on the top and bottom of the stabilizer.

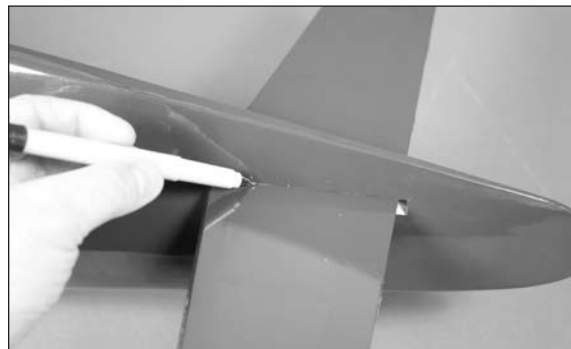

- 9. Remove the stabilizer from the fuselage. Use a hobby knife and a new #11 blade to trim the covering 1/16-inch (1.5mm) inside the lines drawn in the previous step. Remove the covering, exposing the wood at the center of the stabilizer.

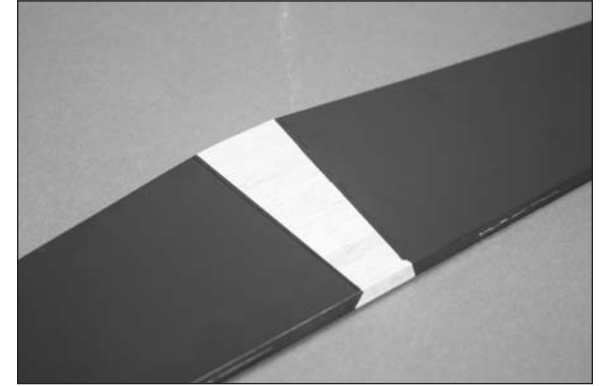

**Note:** Make sure to use a new #11 blade and use light pressure to trim only the covering. Avoid cutting into the underlying wood, which could weaken the structure of your model.

- 10. Use a hobby knife with a #11 blade to remove the covering from the elevators for the 3mm metal joiner rod.

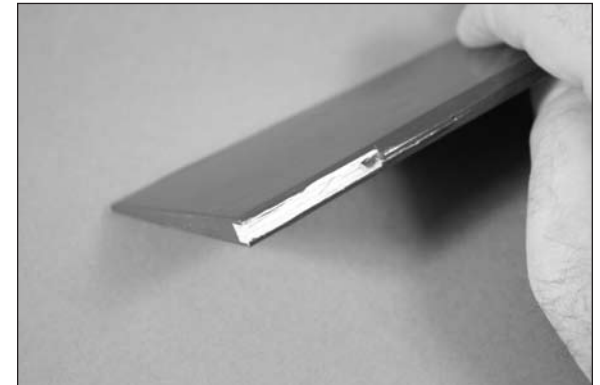

□ 11. Fit the joiner wire into the elevators. Check to make sure the elevators are in alignment with each other by placing the assembly on a flat surface. It may be necessary to bend the joiner wire slightly to align both elevator halves. Make sure to mark the elevators and joiner wire so they can be oriented later in this section of the manual.

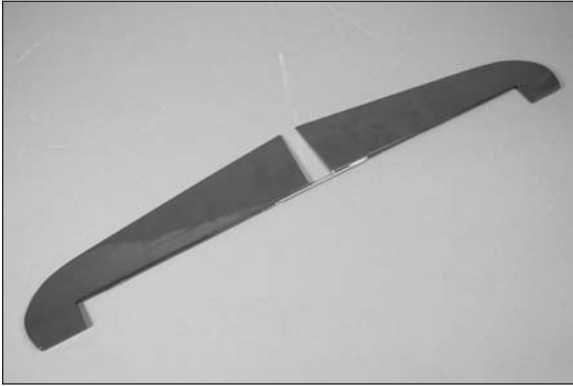

□ 12. Remove the joiner wire from the elevators. Use medium grit sandpaper to roughen the 3mm metal joiner rod where it will contact the elevators.

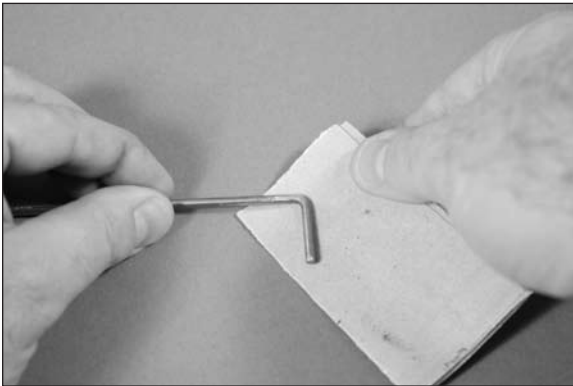

□ 13. Place low-tack tape 1/16-inch (1.5mm) around the outside of the opening in the fuselage for the stabilizer. Use tape on both sides of the fuselage.

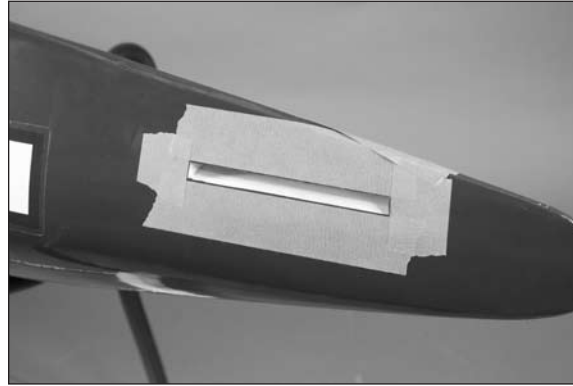

□ 14. Place the joiner wire in the slot for the stabilizer. The joiner wire must be in position before gluing the stabilizer; it cannot be inserted after the stabilizer is in position.

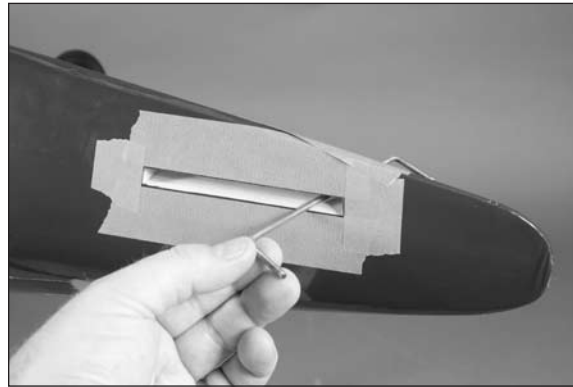

□ 15. Slide the stabilizer into the slot in the fuselage. Apply 30-minute epoxy to the exposed wood at the center of the stabilizer. Make sure to apply epoxy on both the top and bottom of the stabilizer.



□ 16. Position the stabilizer following steps 5 through 7. Remove any excess epoxy from the stabilizer and fuselage using denatured alcohol and a paper towel.

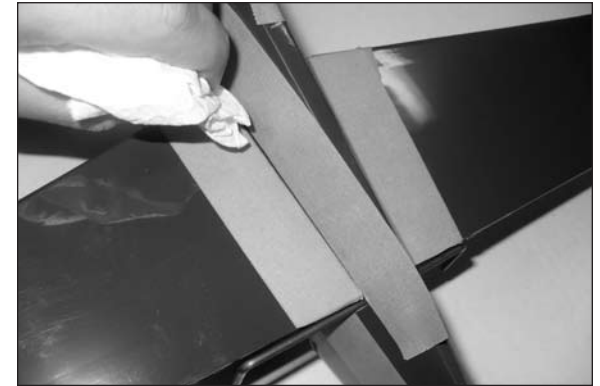

□ 17. After around 25 minutes, before the epoxy fully cures, carefully remove the tape from around the stabilizer. Pull the tape away from the fuselage, being careful not to disturb the position of the stabilizer. This will allow the epoxy to flow out slightly, leaving a fillet between the fuselage and stabilizer. Allow the epoxy to fully cure before disturbing the airframe.



□ 18. Once the epoxy fully cures, the wing can be removed from the fuselage by removing the two 8-32 bolts using a 9/64-inch hex wrench.

□ 19. Cut two 1½-inch (38mm) wide pieces of waxed paper. Tape the waxed paper to the stabilizer so the joiner wire doesn't get accidentally glued to the stabilizer when the elevators are installed.

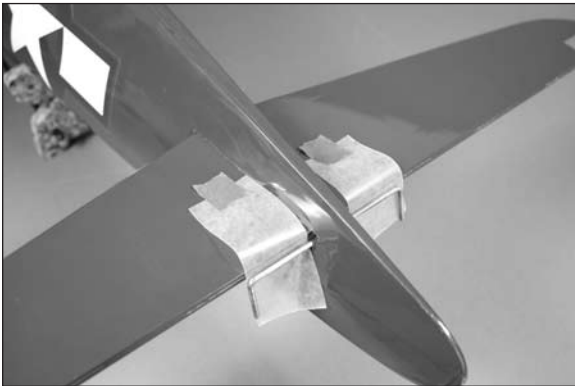

**Note:** Once the epoxy has fully cured, the wing can be removed from the fuselage using a 9/64-inch hex wrench. Using small 1/4-inch (6mm) pieces of the included safety tubing on the shaft of the 8-32 wing bolts will help to keep the bolts with the wing.



□ 20. Use a pin vise and 1/16-inch (1.5mm) drill bit to drill a hole in the center of each hinge slot. This creates a tunnel for the CA to wick into, creating a better bond between the hinge and surrounding wood. Drill holes in both the elevator and stabilizer hinge slots.



□□ 21. Place a T-pin in the center of three hinges. Insert the hinges into the elevator as shown.

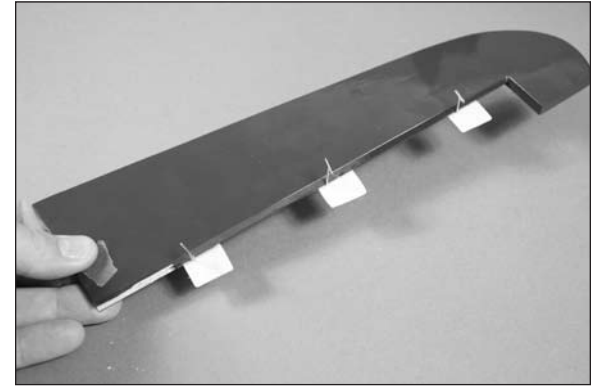

□□ 22. Check the fit of the elevator to the stabilizer. Make sure the joiner wire is inserted into the elevator in the same orientation as step 11. The elevator should fit tightly against the stabilizer.

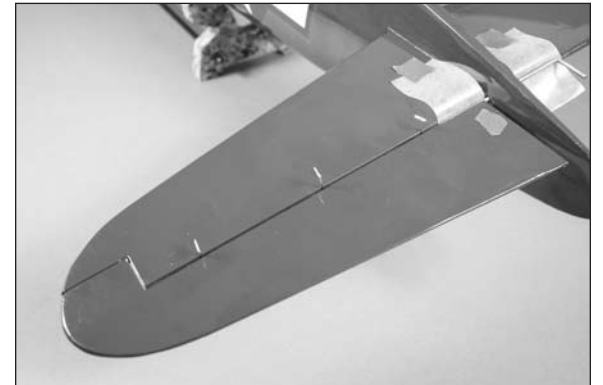

- 23. Check the fit of the opposite elevator to the stabilizer following steps 21 and 22.

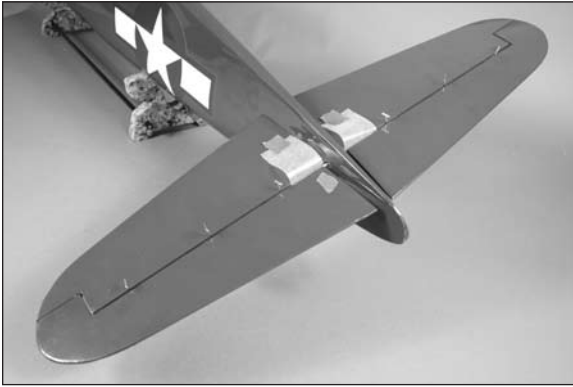

- 24. Remove the elevators from the stabilizer. Mix a small amount of 30-minute epoxy and apply it to the joiner wire and into the hole and slot in the elevator using a toothpick.

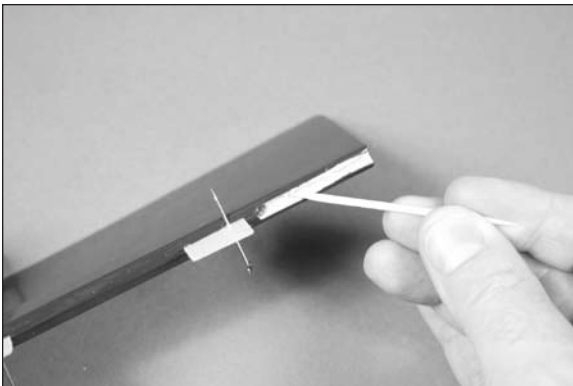
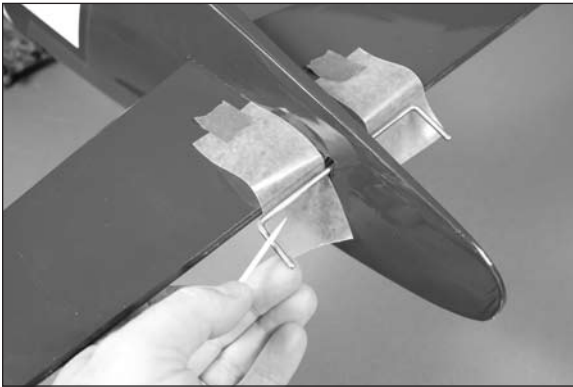

- 25. Place both elevators into position once epoxy has been applied. Use a paper towel and rubbing alcohol to remove any excess epoxy before it begins to cure. Make sure to check the alignment of the elevators to make sure they are in alignment with each other while the epoxy cures.

- 26. Remove the waxed paper from the stabilizer. Remove the T-pins from the hinges. Position the elevators so there is an equal gap between the tips of the balance tabs on the elevator and stabilizer.

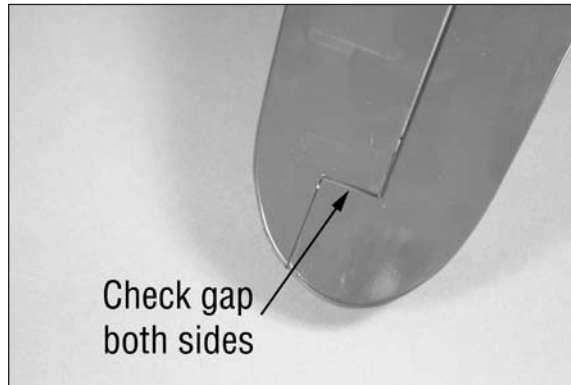

- 27. Saturate each of the three hinges on both the top and bottom of the hinge. Set the assembly aside to cure.

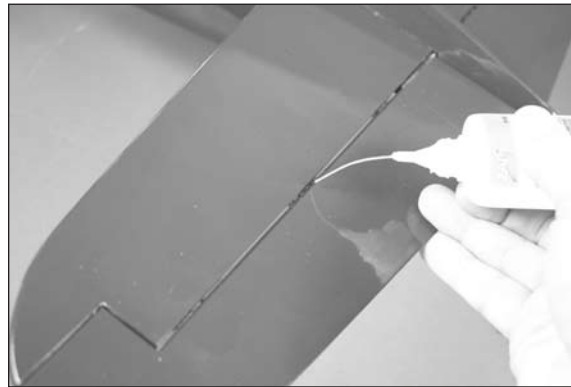

**Important:** Allow the CA to cure WITHOUT using CA accelerator. This is necessary to allow the CA to soak into the hinge, creating the best bond between the hinge and surrounding wood.

- 28. Once the CA and epoxy has cured, check that all the hinges are secure by gently trying to separate the elevators from the stabilizer. If any hinges are loose, re-apply CA to the loose hinges.

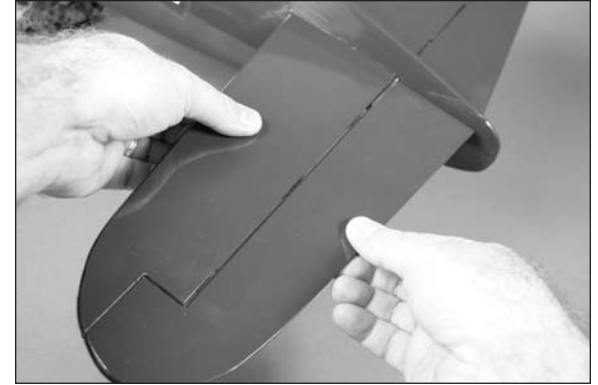

- 29. Break in the hinges by working the stabilizer up and down a number of times.



## Fin and Rudder Installation

### Required Parts

Fuselage assembly	Rudder and fin
CA hinge (2)	3mm torque rod
Balsa fairing, blue	

### Required Tools and Adhesives

30-minute epoxy	Epoxy brush
Toothpick	Hobby knife with #11 blade
Waxed paper	Low-tack tape
Ruler	T-pins
Medium grit sandpaper	Thin CA
Petroleum jelly	Paper towels
Rubbing alcohol	

**Important:** Please follow the instructions provided to install the rudder and fin. We have tried various methods, and the provided sequence will yield the best results and alignment for your model.

□ 1. Locate the rudder, fin and 3mm torque rod. You will also need the fuselage for the installation of the fin and rudder.



□ 2. Separate the rudder from the fin. Set the fin and two CA hinges aside.

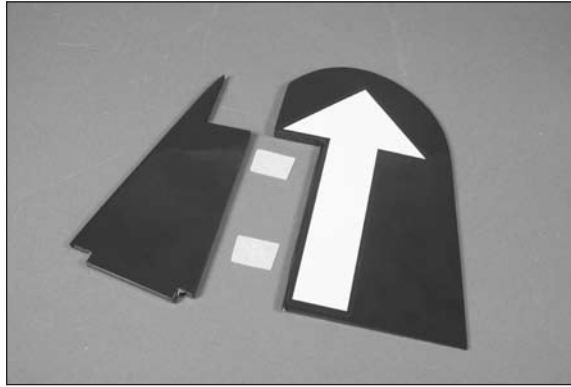

□ 3. Use a hobby knife with a #11 blade to remove the covering from the rudder for the 3mm torque rod.

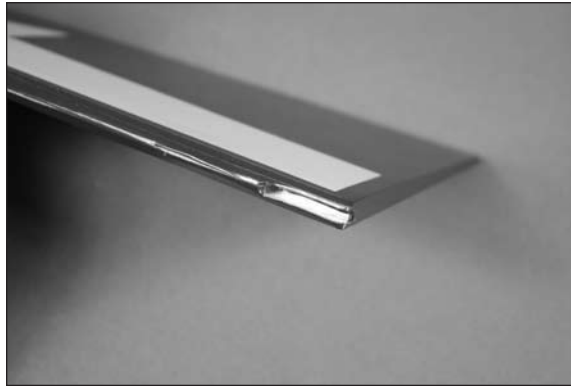

□ 4. Fit the torque rod into the rudder. The front edge of the torque rod will align with the rudder hinge line.

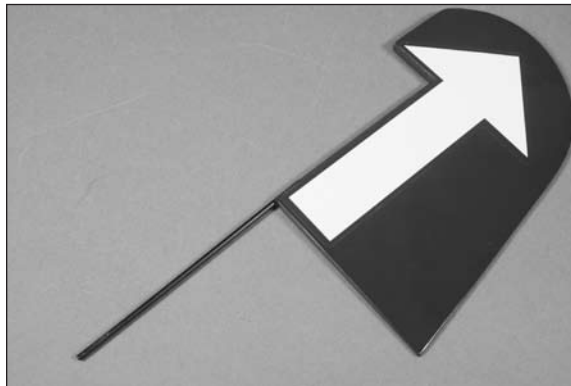

□ 5. Remove the torque rod from the rudder. Use medium grit sandpaper to roughen the torque rod where it will contact the rudder.

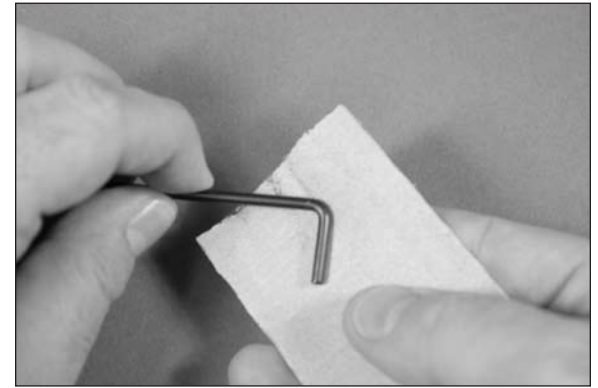

□ 6. Place the torque rod into the rudder. Use low-tack tape to hold the torque rod in position.

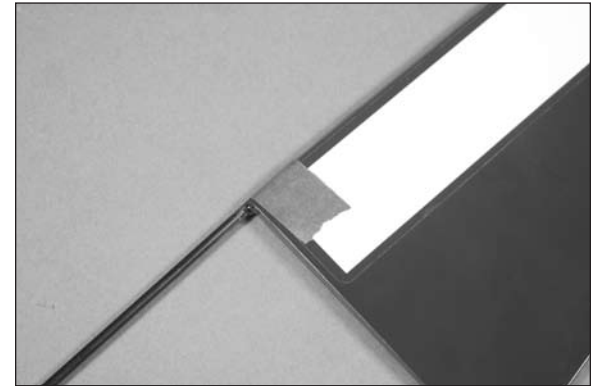



□ 7. Use a pin vise and 1/16-inch (1.5mm) drill bit to drill a hole in the center of each hinge slot. This creates a tunnel for the CA to wick into, creating a better bond between the hinge and surrounding wood. Drill holes in both the rudder and fin hinges slots.

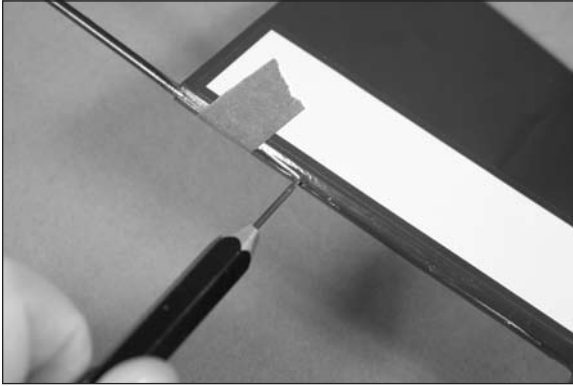

□ 8. Check the fit of the rudder to the fin. The rudder should fit tightly against the fin.



**Hint:** Placing the balance tab against the fin and taping the balsa fairing directly to the bottom of the rudder will produce the same gap for both when the rudder is hinged to the fin later in this section of the manual.

□ 9. Check the position of the rudder on the fin, making sure the balance tab of the rudder is resting on the top of the fin. You may not be able to move the rudder. Use tape to secure the rudder to the fin.

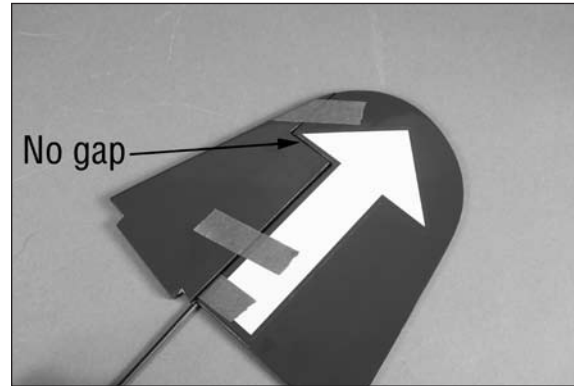

□ 10. Use low-tack tape to attach the balsa fairing to the bottom of the rudder. The trailing edge of the rudder will flow into the curve of the fairing as shown in the photo.



□ 11. Use a hobby knife and a #11 blade to remove the covering from the top of the fuselage for the fin position. Also remove the covering on the bottom of the fuselage for the tail wheel bearing block.



□ 12. Test fit the rudder assembly into the fuselage. Make sure to slide the torque rod into the tube inside the fuselage. Check that the bottom edge of the balsa fairing rests flat on the fuselage. The fin will also rest tightly against the top of the fuselage. If not, remove the covering from the bottom of the fin or even lightly sand the bottom of the fin where it contacts the fuselage to correctly position the balsa fairing.

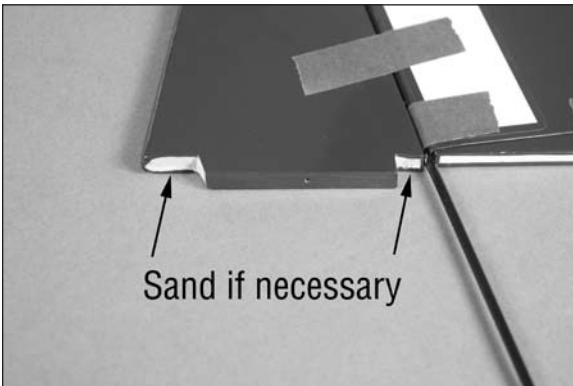

□ 13. Use a felt-tipped pen to trace the outline of the fuselage on the bottom of the fin. Also trace the outline of the front of the fin where it contacts the fuselage.

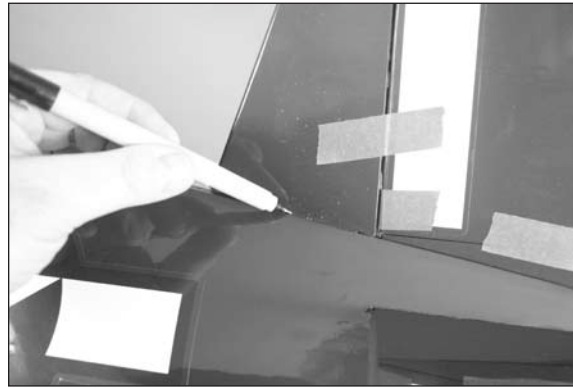

□ 14. Remove the rudder assembly from the fuselage. Use a hobby knife and a #11 blade to trim the covering 1/16-inch (1.5mm) inside the lines drawn in the previous step. Remove the covering, exposing the wood at the bottom of the fin.



**Note:** Make sure to use a new #11 blade and use light pressure to trim only the covering. Avoid cutting into the underlying wood, which could weaken the structure of your model.

□ 15. Use a hobby knife and #11 blade to remove the covering from the top of the fuselage for the fin.



□ 16. Place low-tack tape 1/16-inch (1.5mm) around the outside of the opening in the fuselage for the fin.



□ 17. Apply a thin coat of petroleum jelly to the torque rod to prevent accidentally gluing the rod into the bushing if epoxy happens to run down into the fuselage.



**Important:** Make sure to use enough epoxy to glue the fin securely to the fuselage. Not using enough epoxy may result in a poor bond between the fin and fuselage, which could cause the fin to loosen in flight.

- 18. Mix a 1/3 ounce (10mL) of 30-minute epoxy. Apply the epoxy to the exposed wood at the bottom of the fin as well as to the fuselage where the fin will come in contact with the fuselage.

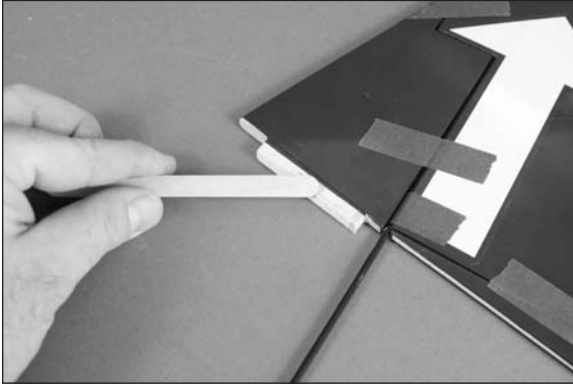

- 19. Slide the fin into position. Use a paper towel and rubbing alcohol to remove any excess epoxy from the fuselage.

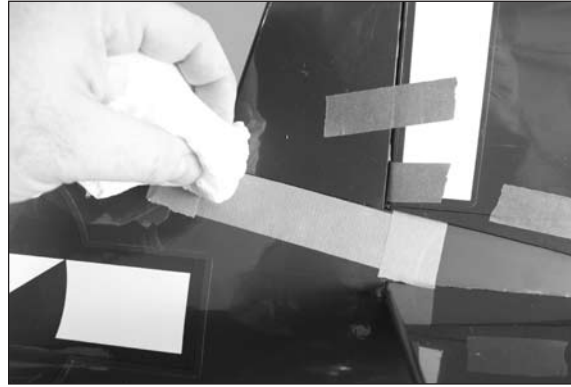

**Important:** If there isn't a fair amount of epoxy to remove, you have not used enough to glue the fin in the fuselage. Remove the fin and apply more epoxy so there is a fair amount of epoxy oozing out when the fin is inserted in the fuselage.

- 20. Check the alignment of the fin to the stabilizer. Position the fin so it is perpendicular to the stabilizer. Use low-tack tape to keep the fin in position.

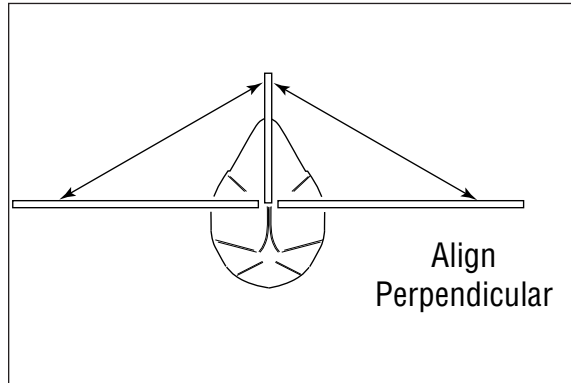

- 21. After around 25 minutes, before the epoxy fully cures, carefully remove the tape from around the fin. Pull the tape away from the fuselage, being careful not to disturb the position of the fin. This will allow the epoxy to flow out slightly, leaving a fillet between the fuselage and fin. Allow the epoxy to fully cure before disturbing the airframe.

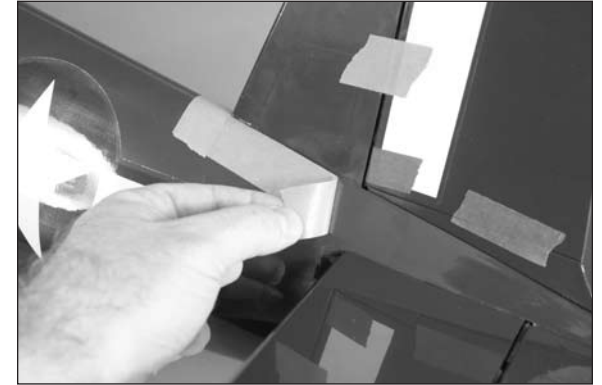

- 22. Remove the rudder from the fin, leaving the torque rod in the fuselage. Place a T-pin in the center of two hinges. Insert the hinges into the rudder as shown.

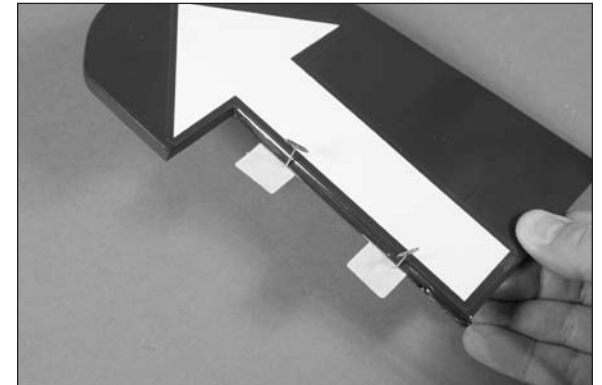

- 23. Cut a 1-inch (25mm) wide pieces of waxed paper. Tape the waxed paper to the fin so the torque rod doesn't get accidentally glued to the fin when the rudder is installed.

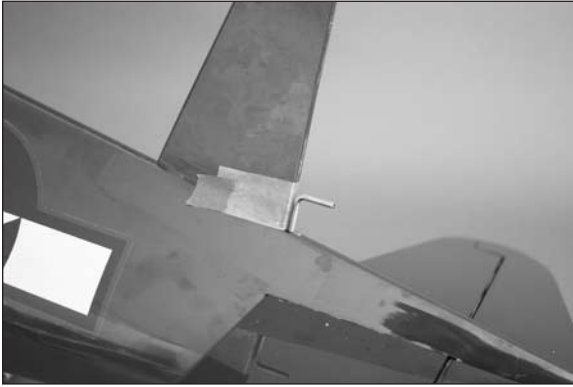

- 24. Mix a small amount of 30-minute epoxy and apply it to the torque rod and into the hole and slot in the rudder using a toothpick.

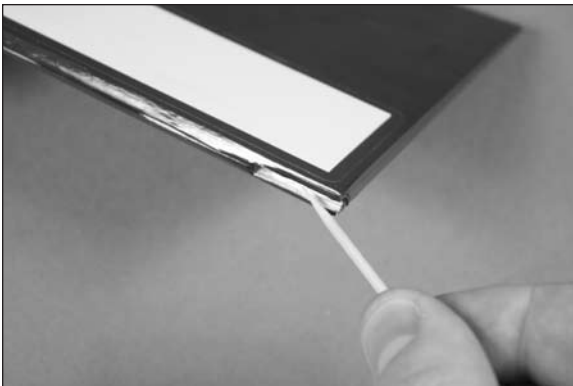

- 25. Place the rudder into position using the hinges. Make sure the torque rod fits into the hole in the rudder.

- 26. Position the rudder so there is a slight gap between the balance tab and the top of the fin. This will set the gap so the rudder can move smoothly. As well, set the clearance for the balsa fairing.

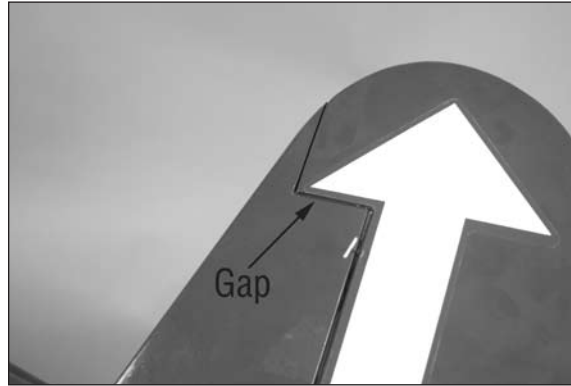

- 27. Use low-tack tape to tape the balsa fairing in position on the fuselage. Make sure the rudder can move freely and not rub against the fairing before gluing the hinges. The gap in step 26 should match the gap in this step.

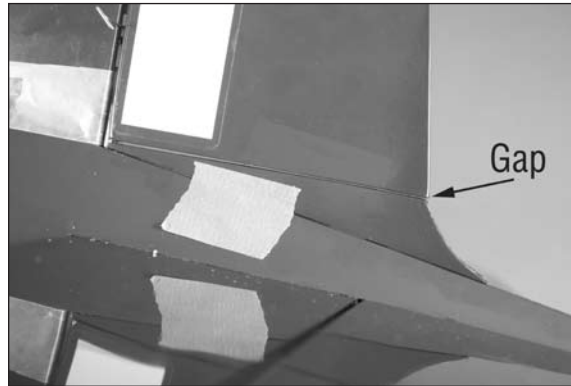

- 28. Remove the tape and waxed paper from the fin. Saturate each of the two hinges on both the top and bottom of the hinge. Set the assembly aside to cure.



**Important:** Allow the CA to cure WITHOUT using CA accelerator. This is necessary to allow the CA to soak into the hinge, creating the best bond between the hinge and surrounding wood.

- 29. Once the CA has cured, check that all the hinges are secure by gently trying to separate the rudder from the fin. If any hinges are loose, re-apply CA to the loose hinges.



30. Break in the hinges by moving the rudder through its range of throw a number of times.

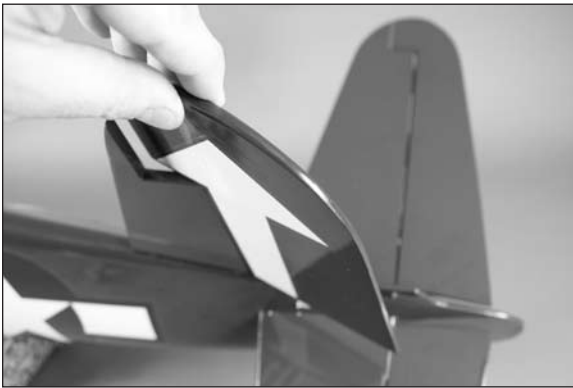
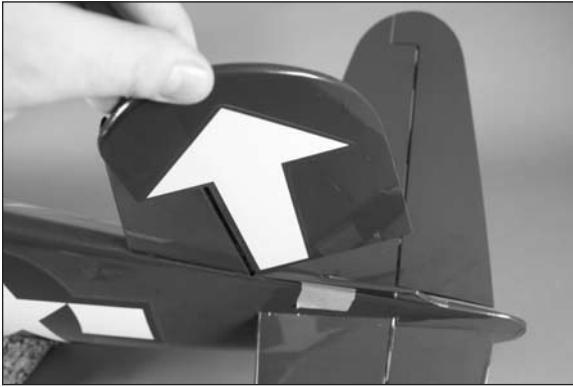

31. With the rudder centered, make sure the balsa fairing is directly under the rudder. Use a felt-tipped pen to trace the outline of the fairing onto the top of the fuselage.



32. Use a hobby knife and a #11 blade to remove the covering from the fuselage 1/16-inch (1.5mm) inside the lines drawn in the previous step.



33. Use medium CA to glue the fairing to the top of the fuselage.



## Receiver, Receiver Battery, Servo and Linkage Installation

### Required Parts

Fuselage assembly	Servo with hardware (2)
Receiver	Receiver battery
Switch harness	Control horn with backplate
Nylon clevis (2)	Safety tubing
Hook and loop strap	
Servo extension, 6-inch (152mm) (3)	
3mm tail wheel wire with 1-inch (25mm) tail wheel	
Tail wheel adapter with setscrew	
2mm x 15mm machine screw (3)	
2mm x 505mm pushrod, rudder	
2mm x 610mm pushrod, elevator	

### Required Tools and Adhesives

Flat file	Ruler
Side cutter	Thin CA
Pin vise	Felt-tipped pen
Pencil	Hex wrench: 2mm (included)
Phillips screwdriver: #1	Hobby knife with #11 blade
Drill bit: 1/16-inch (1.5mm), 5/64-inch (2mm)	

1. Locate the items to install the radio system in the fuselage and connect the linkages. You will also need to have the fuselage for this section of the manual as well and the radio equipment.

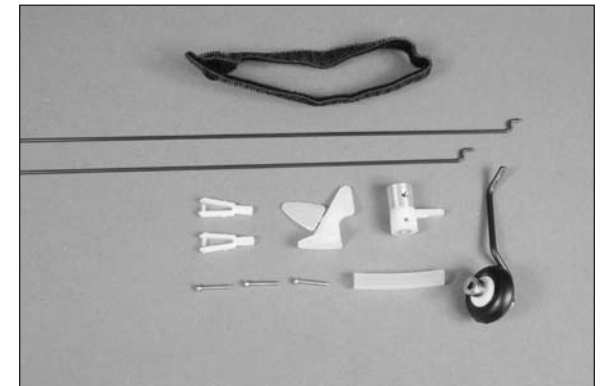

□ 2. Prepare the rudder and elevator servos by installing the brass eyelets and rubber grommets. Use a #1 Phillips screwdriver to remove the servo horn from the servo.

□□ 3. Place the rudder servo in the opening inside the fuselage with the output shaft to the rear of the fuselage. The servo will be centered in the opening to prevent vibrations from the airframe to be transferred to the servo. Use a pencil to mark the location for the screws that will secure the servo to the servo tray.



□□ 4. Use a pin vise and 1/16-inch (1.5mm) drill bit to drill the holes for the four mounting screws.



□□ 5. Use a #1 Phillips screwdriver to run a servo mounting screw in each of the four holes. Make sure to remove the screw before proceeding to the next step.



□□ 6. Apply 2–3 drops of thin CA in each hole drilled. This will harden the surrounding wood, making the screws more secure when installed.

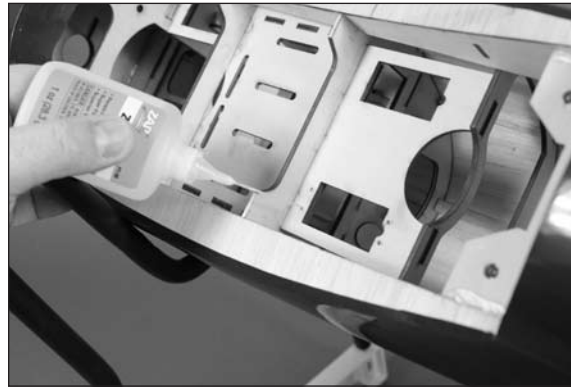

**Important:** Do not use a CA accelerator. Using an accelerator will not allow the CA to soak into the fibers of the wood, hardening the blocks.

□□ 7. Use the screws provided with the servo and a #1 Phillips screwdriver to secure the servo to the servo tray.



□□ 8. Use a pin vise and 5/64-inch (2mm) drill bit to enlarge the hole in the servo arm that is 1/2-inch (13mm) from the center of the arm. Use side cutters to remove any unused arms so they don't interfere with the operation of the servo.

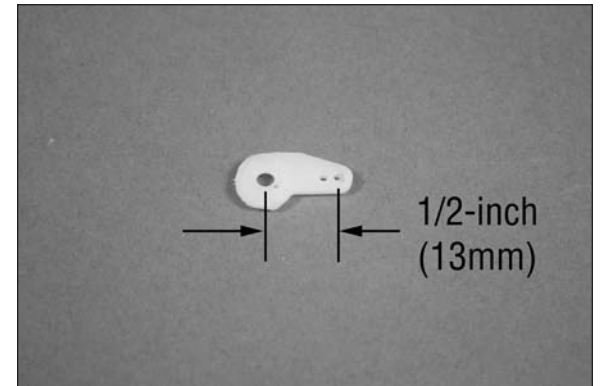

□□ 9. Insert the Z-bend of the 2mm x 505mm rudder pushrod through the hole enlarged in the previous step.

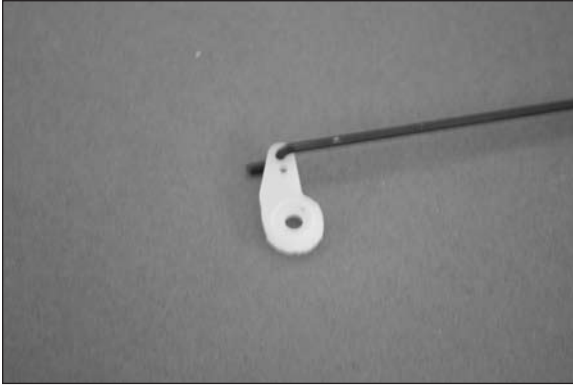

□□ 10. Slide the pushrod into the pushrod tube in the fuselage. Use a hobby knife and #11 blade to remove the covering from the pushrod tube opening at the rear of the fuselage. With the rudder servo centered and the transmitter stick and trim centered, attach the servo horn to the rudder servo so it is perpendicular to the servo centerline.

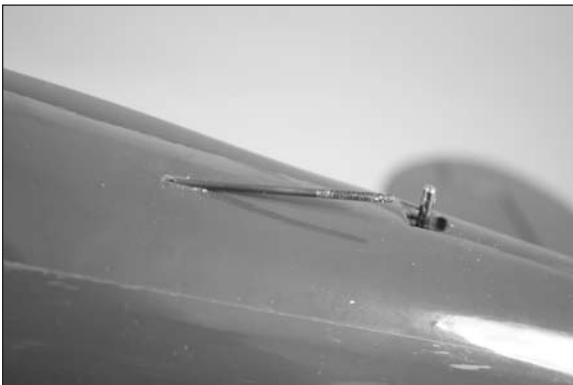

□ 11. Repeat steps 3 through 9 to install the elevator servo and the 2mm x 610mm elevator pushrod in the fuselage.



□ 12. Slide the hatch forward then lift it up at the rear. There are tabs near the rear edge that must clear the top of the fuselage before lifting the hatch, so make sure the hatch is slid forward as far as possible before removal.



□ 13. Mount the receiver switch harness in the fuselage using the hardware provided with the switch. There are multiple locations for the switch, so choose the one that best suits your application.



□ 14. Use the hook and loop strap to secure the receiver battery in the fuselage. Make sure to use foam rubber at any point the battery may contact the airframe to protect it from vibrations. Plug the battery into the switch harness at this time as well.

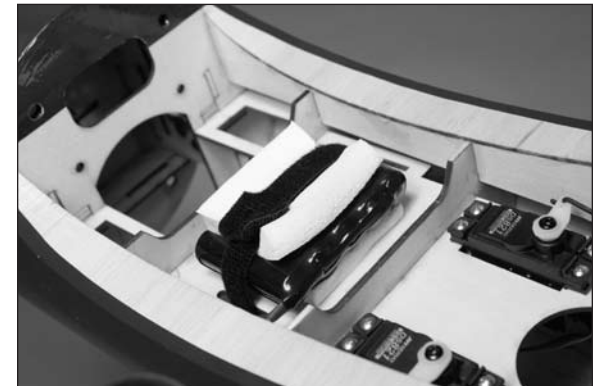

□ 15. Plug the rudder and elevator servos into the receiver. Plug 6-inch (152mm) extensions in the receiver for the ailerons and retracts at this time as well. Make sure to mark the extensions so they can be easily identified from inside the fuselage. Plug the switch harness into the battery port of the receiver.

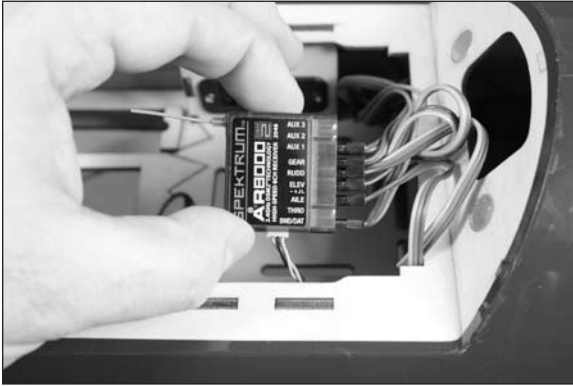

□ 16. Use the hook and loop strap to secure the receiver in the fuselage. Make sure to isolate the receiver from the airframe using foam rubber.



□ 17. Mount the remote receiver in the airframe using hook and loop tape. Make sure the antenna on the remote receiver are 90-degrees in relationship to the main receiver antenna. Place the remote receiver as far away from the main receiver as possible for the best radio reception.

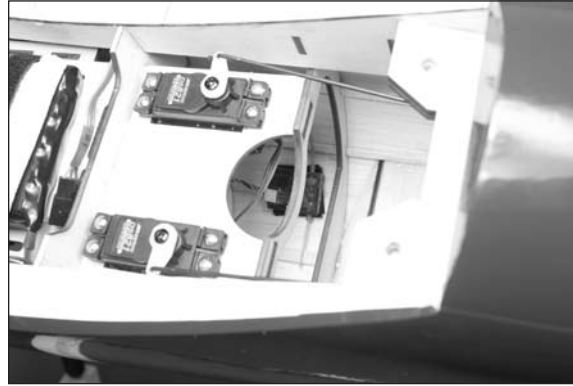

□ 18. Use a hobby knife with a #11 blade to cut a 1/4-inch (6mm) piece from the safety tubing.

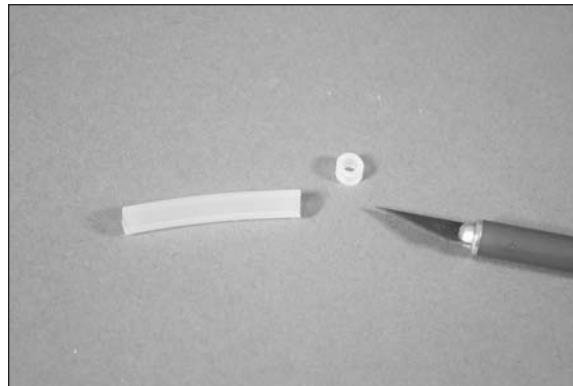

□ 19. Slide the safety tubing on the nylon clevis. With the radio on and the rudder centered at neutral, thread the clevis on the pushrod. Place the tail wheel adapter on the rudder torque rod. The aluminum portion of the adapter will face toward the fuselage. Connect the clevis to the adapter. Lightly tighten the setscrew using a 2mm hex wrench to mark the rudder torque rod.



**Note:** The arm on the adapter will angle toward the rear of the fuselage. This is necessary so the pushrod does not bind when operating the rudder.

**Note:** Always use threadlock on metal-to-metal fasteners to prevent them from vibrating loose.

□ 20. Remove the adapter from the torque rod. Use a flat file to make a flat on the rudder torque rod. File the location marked by the setscrew in the previous step. This will keep the adapter from slipping on the torque rod and must be done to ensure safe operation of your model. Once the flat has been made, secure the adapter to the torque rod.

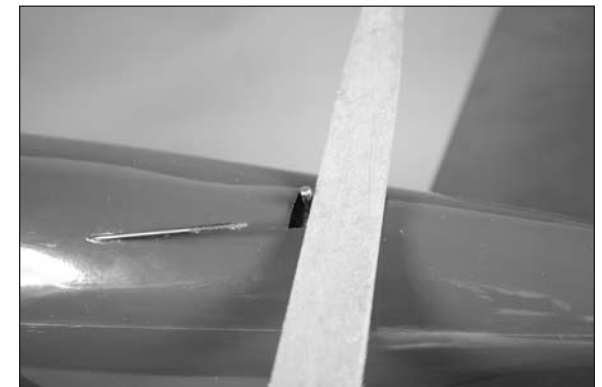

□ 21. Place the tail wheel wire in the adapter with the tail  
*Hangar 9 F4U-1D Corsair 50 ARF*



wheel aligned to the fuselage centerline. Tighten the setscrew to mark the location of the setscrew on the tail wheel wire. Remove the wire and use a flat file to file a flat on the tail wheel wire for the setscrew in the adapter.

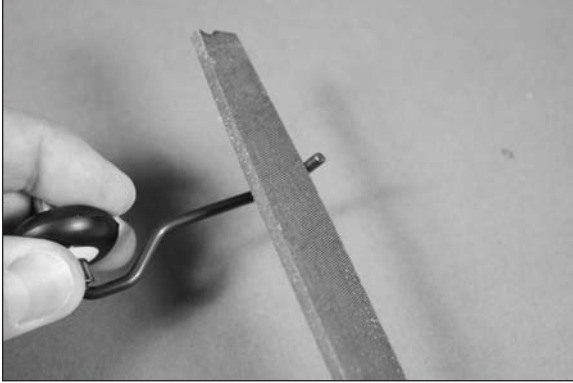

**Note:** Always use threadlock on metal-to-metal fasteners to prevent them from vibrating loose.

□ 22. Place the tail wheel wire in the tail wheel adapter. Use the included 2mm hex wrench to tighten the setscrew to secure the tail wheel wire. Make sure the tail wheel is aligned with the fuselage centerline. If not, use a flat file to change the position of the flat on the tail gear wire made in step 20.

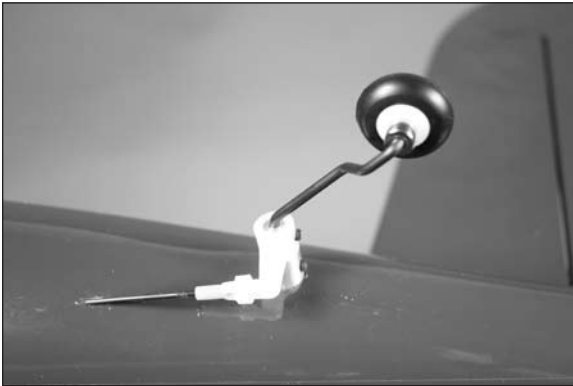

□ 23. Use a hobby knife to remove the backplate from the control horn. Place the control horn on the elevator so it aligns with the elevator pushrod. Also check that the holes in the horn align with the hinge line.

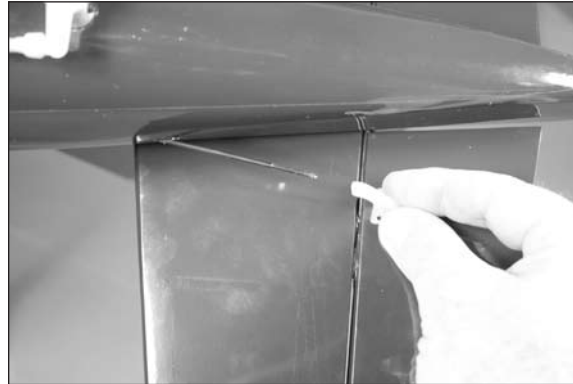

□ 24. Use a felt-tipped pen to mark the locations for the control horn mounting screw. Check to make sure the location of the control horn mounting screws will not interfere with the elevator joiner wire. If not, use a pin vise and a 5/64-inch (2mm) drill bit to drill the holes through the elevator for the mounting screws. Place 2–3 drops of thin CA in each hole to harden the surrounding wood.

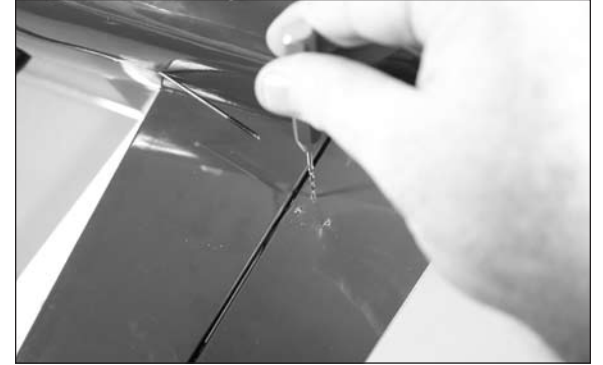

□ 25. Attach the control horn to the elevator using three 2mm x 15mm machine screws and the control horn backplate.

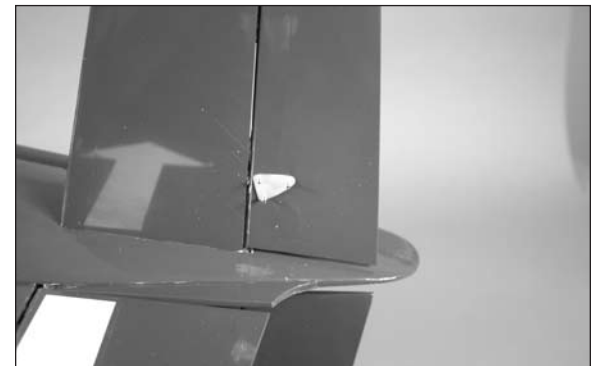
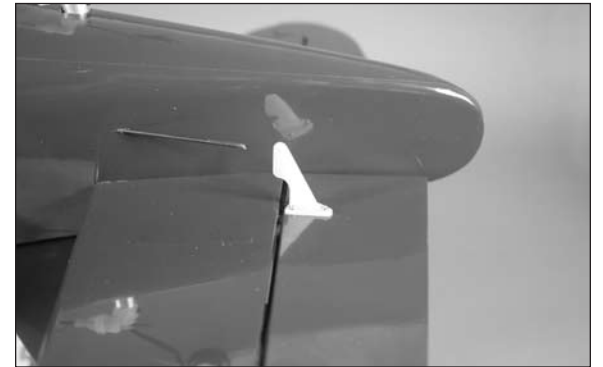

26. Use a hobby knife with a #11 blade to cut a 1/4-inch (6mm) piece from the safety tubing.

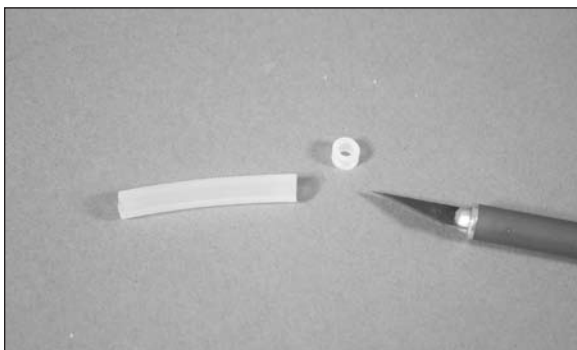

27. Slide the safety tubing on the nylon clevis. With the radio on and the elevator servo centered, thread the nylon clevis on the pushrod. Thread the clevis on enough so the elevator is centered when the clevis is connected. Connect the clevis to the outer hole of the control horn. Once set, slide the safety tubing over the forks of the clevis to keep the clevis from opening accidentally.

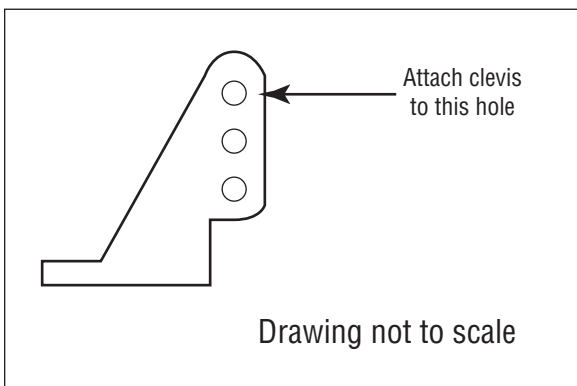

## Engine and Fuel Tank Installation

### Required Parts

Fuselage assembly	Fuel tank assembly
Transmitter	Servo with hardware
Safety tubing	Engine
Fuel tank brace, upper	Fuel tank brace, rear
Nylon engine mount (2)	Nylon clevis
#4 washer (4)	#6 washer (4)
4-40 lock nut (4)	6-32 blind nut (4)
Plywood engine template	
2mm x 10mm washer head screw, black (4)	
4-40 x 1-inch socket head cap screw (4)	
6-32 x 3/4-inch socket head cap screw (4)	
Pushrod housing, 8-inch (200mm)	
2mm x 215mm pushrod, throttle	

### Required Tools and Adhesives

Drill	Side cutter
Pin vise	Medium grit sandpaper
Scissors	Ruler
Low-tack tape	Threadlock
Phillips screwdriver: #1	Hobby knife with #11 blade
Pencil	Nut driver: 1/4-inch
Hex wrench: 3/32-inch, 7/64-inch	
Drill bit: 1/16-inch (1.5mm), 5/64-inch (2mm), 11/64-inch (4.5mm)	

1. Locate the items necessary to install the engine and fuel tank in the fuselage. The fuselage will be required for this section of the manual.

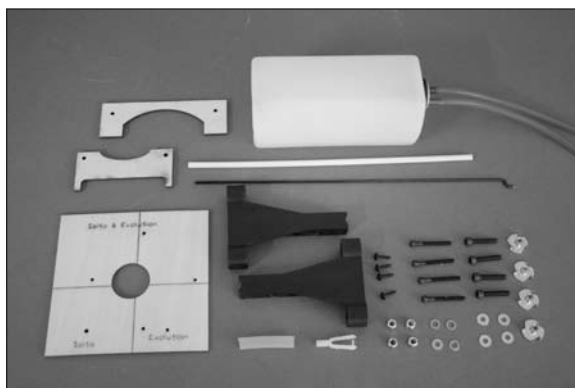

2. Use low-tack tape to secure the engine mounting template to the fuselage. Make sure to select the template specific to your particular engine (Saito & Evolution or FG-14B). Use a drill and 1/16-inch (1.5mm) drill bit to drill the pilot holes for the engine mount into the firewall. Drill the hole for the throttle pushrod at this time as well.

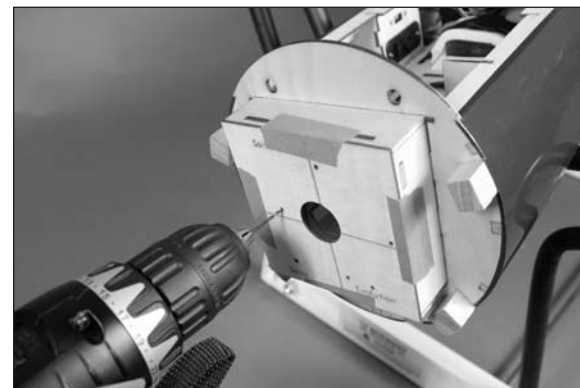

3. Remove the template from the fuselage. Use a drill and 11/64-inch (4.5mm) drill bit to enlarge all five holes drilled in the previous step.



- 4. Use an 8-32 x 3/4-inch socket head cap screw and #6 washer to draw the four 6-32 blind nuts into the firewall from the inside of the fuselage. Use a 7/64-inch hex wrench to tighten the bolts. Remove the bolt once all the blind nuts are installed.

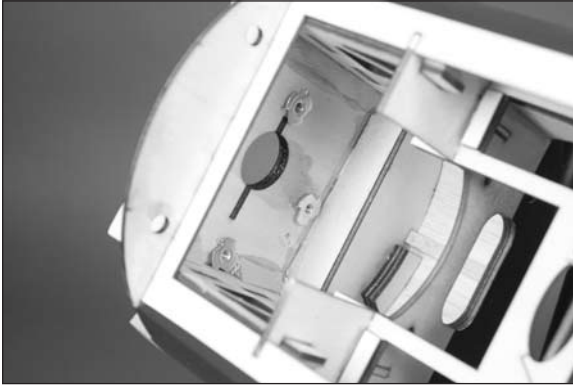

**Note:** Always use threadlock on metal-to-metal fasteners to prevent them from vibrating loose.

- 5. Use four 6-32 x 3/4-inch socket head cap screws and four #6 washers to attach the two nylon engine mounts to the firewall. Do not fully tighten the screws at this time.



- 6. Attach the engine to the nylon engine mount using four 4-40 x 1-inch socket head cap screws, four #4 washers and four 4-40 lock nuts. Place the washer on the bolt before passing it through the engine mounting lug. The forward bolt is located in the hole closest to the end of the mount, while the rear bolt is in the first oval hole. Use a 3/32-inch hex wrench and 1/4-inch nut driver to tighten the hardware. Check that the holes in the mount set the drive washer 4<sup>15</sup>/<sub>16</sub>-inches (124.5mm) forward of the firewall as shown. Use a 7/64-inch hex wrench to tighten the screws securing the mount to the firewall.

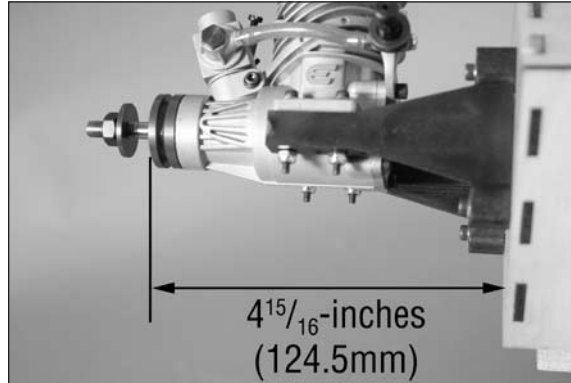

- 7. Prepare and mount the throttle servo in the radio tray using the hardware provided with the servo and a #1 Phillips screwdriver. Follow the same procedure as the rudder and elevator servos to mount the throttle servo. Don't forget to plug the throttle servo into the receiver.



- 8. Locate the 8-inch (200mm) pushrod housing. Use medium grit sandpaper to roughen the first 1/2-inch (13mm) of the tube, and a 1/2-inch wide section centered 3<sup>1</sup>/<sub>2</sub>-inches (90mm) from the end of the tube as shown.

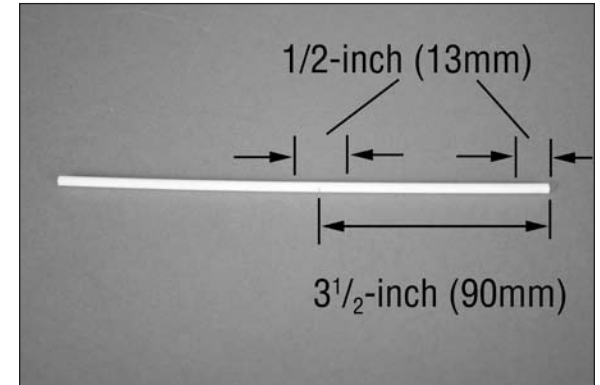

- 9. Slide the tube into the fuselage. Position the tube so 1/8-inch (3mm) extends into the fuselage. Use medium CA to glue the tube in the fuselage.

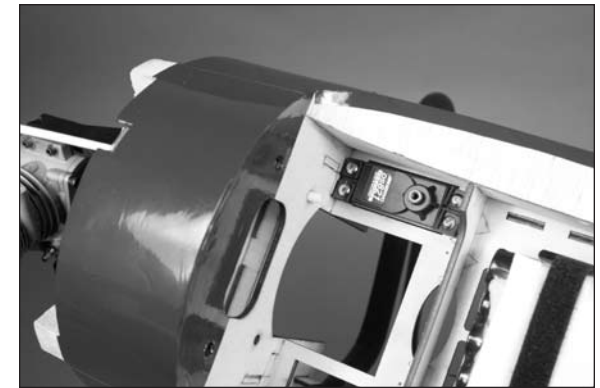

□ 10. Use side cutters to trim the tube flush to the rear of the engine mounting lug.

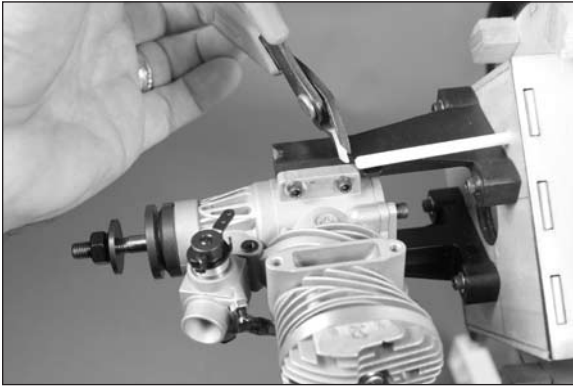

□ 11. Use a pin vise and 5/64-inch (2mm) drill bit to enlarge the hole in the servo arm that is 1/2-inch (13mm) from the center of the arm. Use side cutters to remove any unused arms so they don't interfere with the operation of the servo.

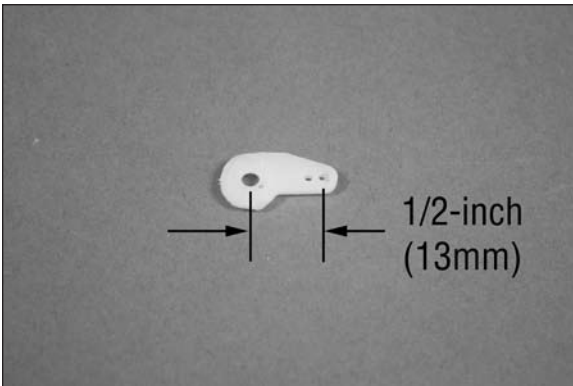

□ 12. (Two-stroke) Insert the Z-bend of the 2mm x 215mm throttle pushrod through the hole enlarged in the previous step.

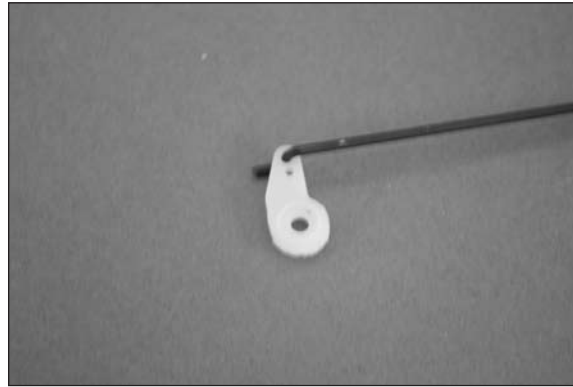

□ 13. (Two-stroke) Center the throttle stick and trim. Slide the pushrod into the tube installed in the fuselage. Attach the servo arm to the throttle servo perpendicular to the throttle centerline. Bend the pushrod slightly so it is parallel to the top of the servo to prevent binding.



□ 14. (Two-stroke) Use a hobby knife with a #11 blade to cut a 1/4-inch (6mm) piece from the safety tubing.

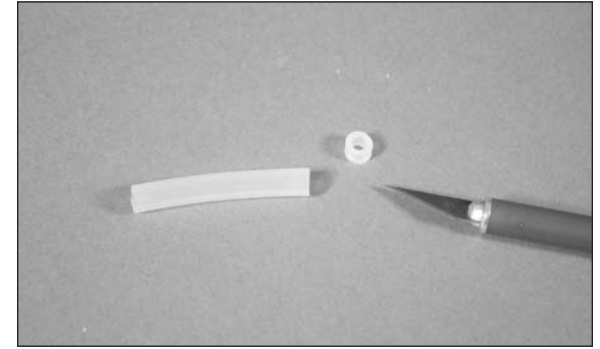

□ 15. (Two-stroke) Slide the safety tubing over the nylon clevis. Thread the clevis on the pushrod and attach it to the carburetor arm.

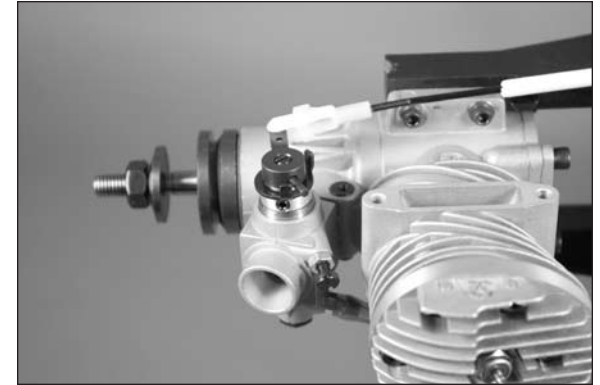

**Note:** Always use threadlock on metal-to-metal fasteners to prevent them from vibrating loose.

□ (Four-stroke throttle linkage) When installing a four-stroke engine, the Z-bend in the pushrod will connect to the carburetor arm. Use the included pushrod connector at the servo to connect the pushrod at the servo. Use a 1.5mm hex wrench to tighten the setscrew that secures the wire to the connector.



**Note:** Use the following images to aid in the placement of the components for the four-stroke gas engine.

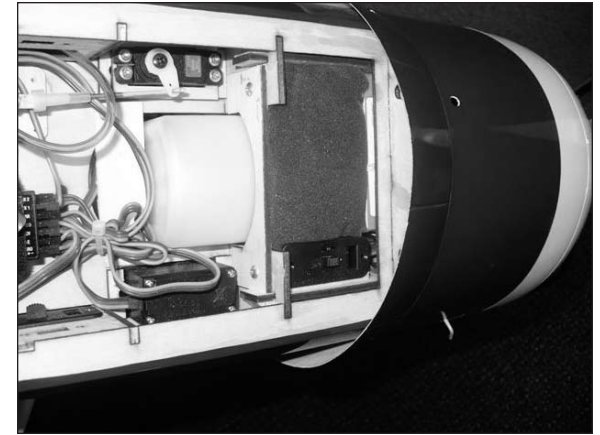
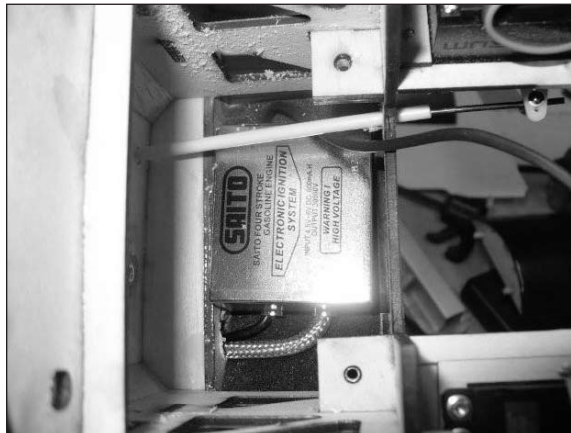

□ 16. Check the operation of the throttle. The carburetor should be open slightly when the trim is centered, but closed if the trim is set to close the throttle. It may be necessary to adjust the throw at the radio slightly to operate the throttle from fully open to fully closed.

□ 17. Prepare the holes for the fuel tank braces by using a #1 Phillips screwdriver to thread a 2mm x 10mm black washer head screw into the four pre-drilled holes as shown. Apply 2-3 drops of thin CA in each hole to harden the surrounding wood.

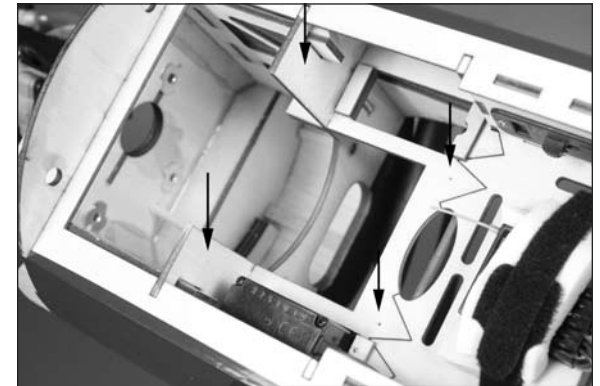

18. Inspect the fuel tank to determine the location of the lines that will connect to the muffler and carburetor. Also note the orientation of the vent line inside the tank.

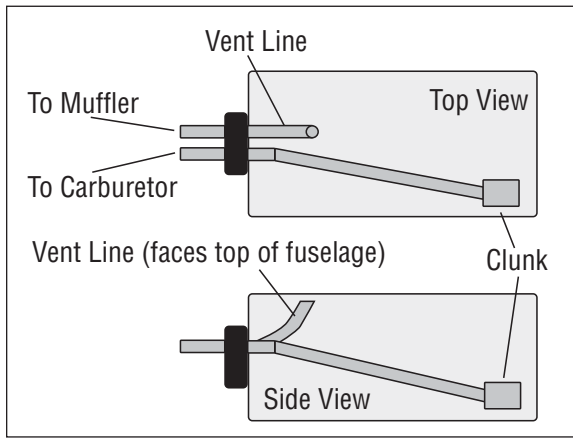

**Note:** The fuel stopper and the fuel tubing are not gasoline compatible and need to be changed out if installing the FG-14B.

19. Place the fuel tank into the fuselage. Use the four 2mm x 10mm black wood screws, rear fuel tank brace and upper fuel tank brace to secure the tank in the fuselage.

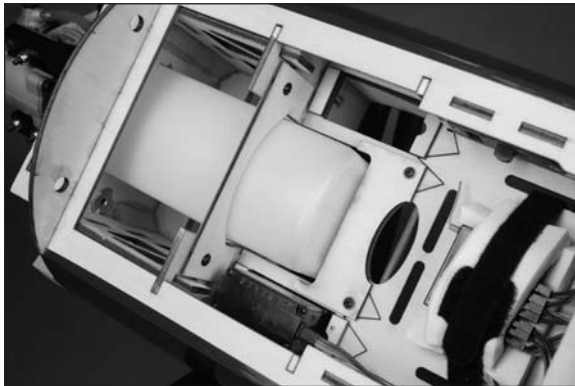

**Note:** The fuel tank has an offset fuel stopper, that when properly installed, this stopper is located towards the bottom of the fuel tank and is centered into the opening in the firewall.

## Motor and Battery Installation

### Required Parts

Fuselage assembly	#6 washer (4)
8-32 blind nut (4)	3mm washer (2)
Propeller adapter	Motor with hardware
Hook and loop strap	Tie-wraps (not included)
6-inch (152mm) servo extension	
Electronic speed control (ESC)	
3mm plywood battery tray support tab	
Pre-assembled plywood motor mounting box	
3mm plywood motor mounting template	
3mm plywood battery plate	
3mm x 12mm machine screw (2)	
6-32 x 3/4-inch socket head cap screw (4)	

### Required Tools and Adhesives

Low-tack tape	Scissors
Thin CA	Medium CA
Drill	Two-sided tape
Rotary tool	Threadlock
Hex wrench: 2mm, 2.5mm, 7/64-inch	
Phillips screwdriver: #1, #2	
Drill bit: 1/16-inch (1.5mm), 11/64-inch (4.5mm)	

1. Locate the items necessary to install the motor on the fuselage. The fuselage will be required for this section of the manual.

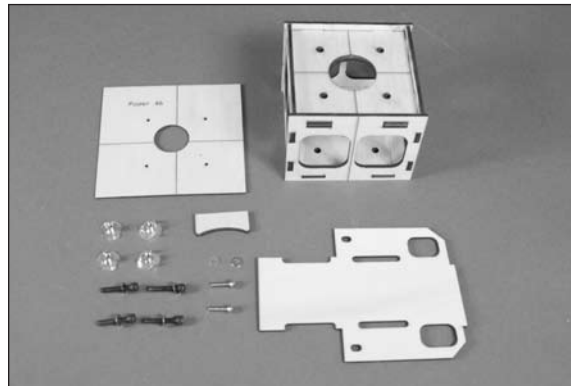

2. Use low-tack tape to secure the engine mounting template for the Power 46 installation to the fuselage. Use a drill and 1/16-inch (1.5mm) drill bit to drill the pilot holes for the engine mount into the firewall. Drill the hole for the throttle pushrod at this time as well.

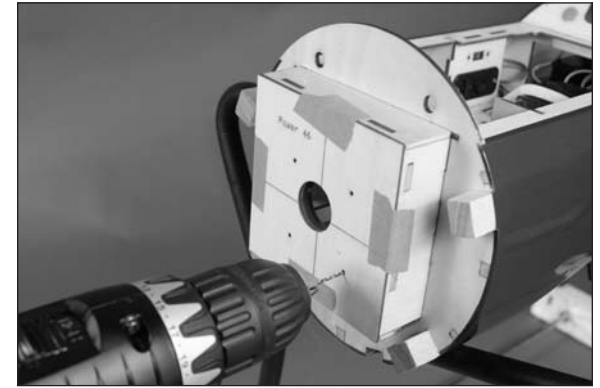

3. Remove the template from the fuselage. Use a drill and 11/64-inch (4.5mm) drill bit to enlarge the holes.

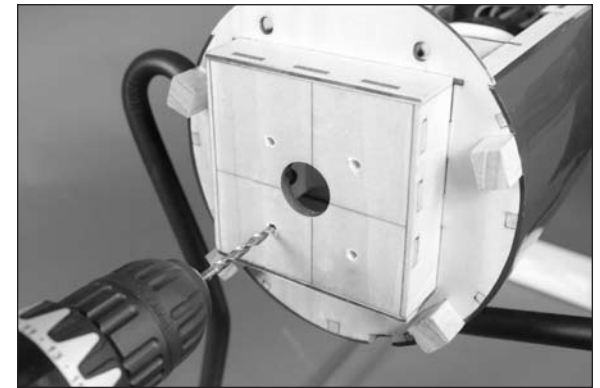

- 4. Use an 8-32 x 3/4-inch socket head cap screw and #6 washer to draw the four 6-32 blind nuts into the firewall from the inside of the fuselage. Use a 7/64-inch hex wrench to tighten the bolts. Remove the bolt once all the blind nuts are installed.

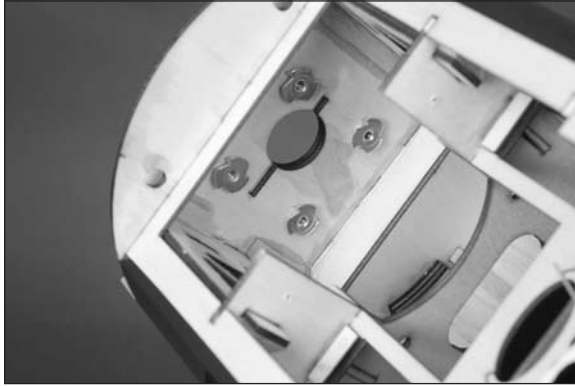

**Note:** Always use threadlock on metal-to-metal fasteners to prevent them from vibrating loose.

- 5. Prepare the pre-assembled plywood motor mount box by using a 3mm x 12mm and 3mm washer to draw the 3mm blind nuts into the motor mount box as shown. Note that the blind nuts are on the inside of the box, on the side with the larger hole. The 2.5mm hex wrench and hardware for this step are included with the motor.

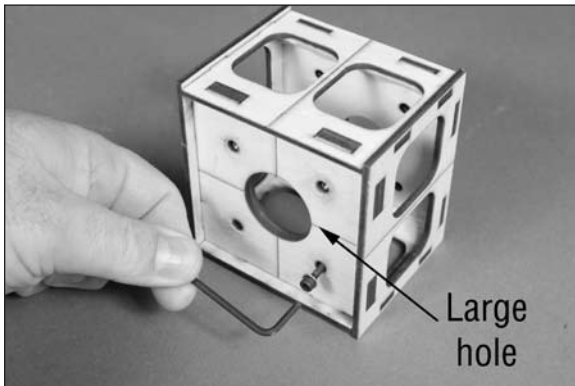

- 6. Use four 6-32 x 3/4-inch socket head cap screws and four #6 washers to attach the pre-assembled plywood motor mount box to the firewall. Make sure the smaller hole in the motor mount box aligns with the hole in the firewall, and that the center lines on the box align with those on the firewall.

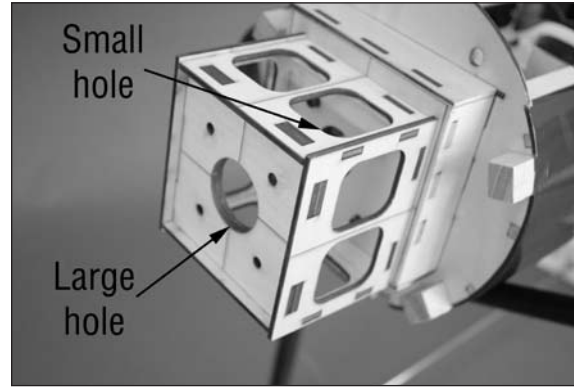

**CAUTION:** Cut the top two 6-32 x 3/4-inch socket head caps screws down in length so they do not protrude through the firewall. In case you crash and the battery moves forward it will not be punctured by the bolt and cause a potential fire.

- 7. Use medium CA to glue the 3mm plywood battery tray support tab to the underside of the radio tray. The curve in the tab will match the lightning hole in the radio tray.

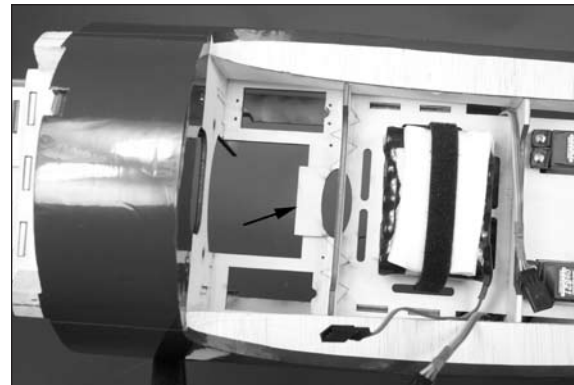

- 8. Place the hook and loop strap through the 3mm plywood battery tray as shown. Note the position of the tab at the front of the tray in relationship to the top view of the tray.

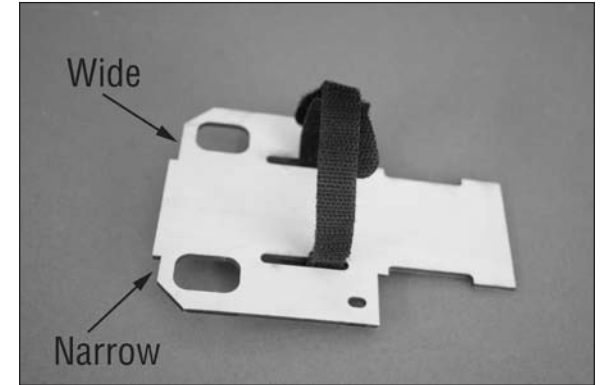

**Note:** Always use threadlock on metal-to-metal fasteners to prevent them from vibrating loose.

- 9. Place the battery tray in the fuselage. The tab in the front of the tray will key into the slot in the firewall. Use two 3mm x 12mm machine screws and two 3mm washers to secure the tray. Use a #2 Phillips screwdriver to tighten the screws.

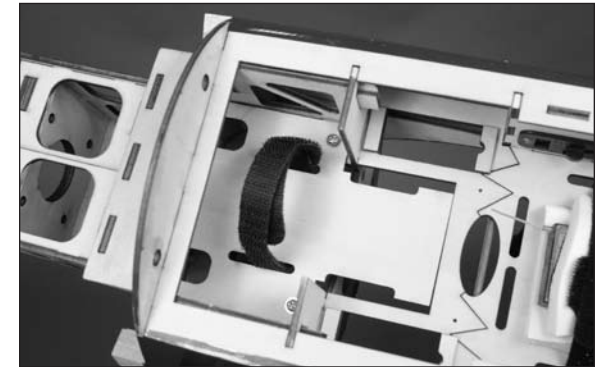

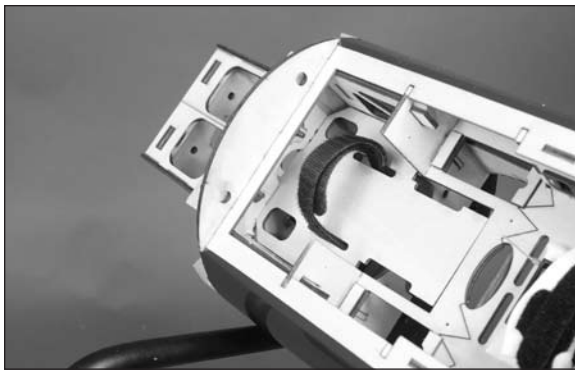

□ 10. The motor shaft must be reversed prior to installing the X-mount. Refer to instructions that came with the motor to do this. Once the shaft has been repositioned, secure the X-mount to the motor using the hardware provided with the motor and a #2 Phillips screwdriver.



□ 11. Attach the propeller adapter on the motor using the hardware provided with the adapter.



**Note:** Always use threadlock on metal-to-metal fasteners to prevent them from vibrating loose.

□ 12. Attach the motor to the motor box using the hardware included with the motor.

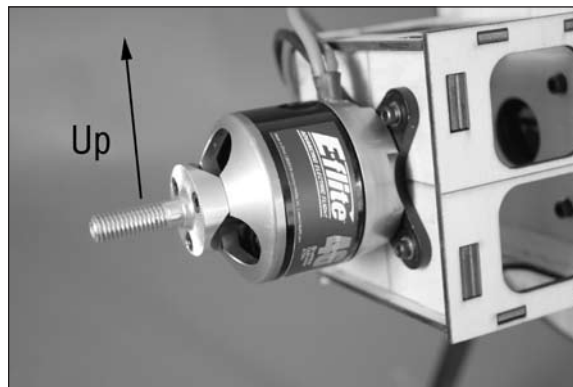

□ 13. Use a drill and rotary tool to cut a hole through the fuselage so the leads from the ESC can pass into the fuselage.

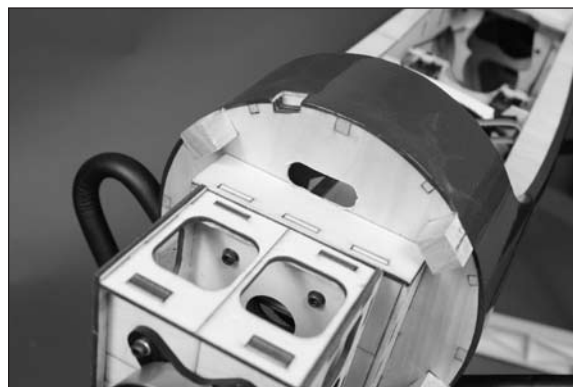

□ 14. Use hook and loop tape to secure the ESC to the bottom of the motor box. Use a tie-wrap to secure the ESC so it won't move from its position. Secure a 6-inch (152mm) servo extension to the receiver lead of the ESC. Pass the leads for the receiver, battery and switch harness through the opening made in the previous step.

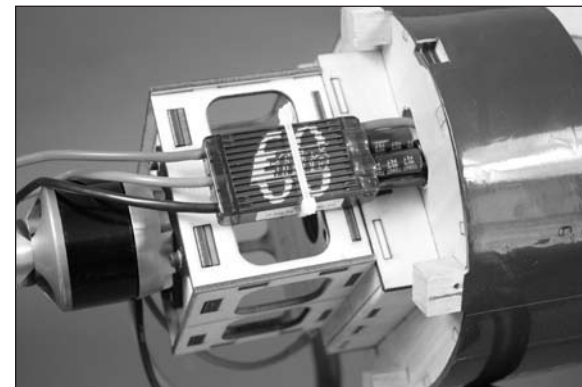

□ 15. Connect the motor leads. Make sure they won't interfere with the operation of the motor. Tie-wrap the motor leads to the motor box if necessary.



**Note:** If you are installing an E-flite motor and speed control, you can match the colors from the motor and ESC. This will result in the motor rotating the correct direction for your model.



□ 16. Pass the switch through the opening in the battery tray. Use two-sided tape to secure the switch in the fuselage. The battery lead will pass through the opposite opening as shown. Plug the extension from the ESC receiver lead into the throttle port of the receiver.

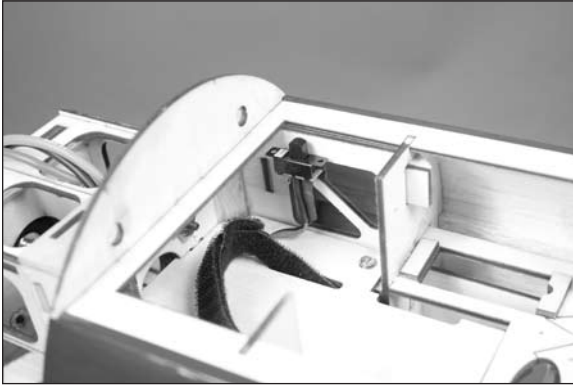

□ 17. The battery is secured in the fuselage using the hook and loop strap. We also recommend using a piece of hook and loop tape between the battery and battery tray to keep the battery from accidentally moving inside the fuselage.

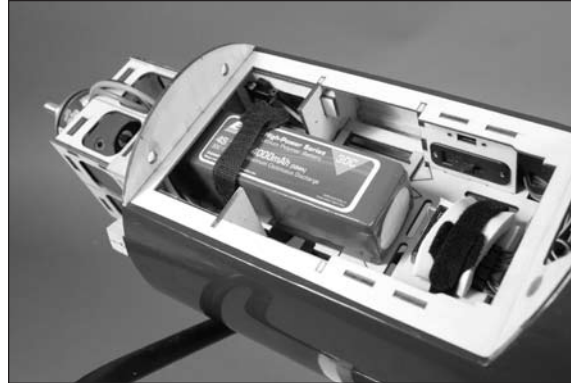

## Cowling Installation

### Required Parts

Fuselage assembly	Cowling
Dummy engine	Spinner nut
Muffler with hardware	Propeller
Fuel filler	
3mm x 15mm washer head screw, black (4)	

### Required Tools and Adhesives

Hobby scissors	Thin CA
Phillips screwdriver: #1	Drill
Silicone adhesive	Drill bit: 5/64-inch (2mm)
Low-tack tape	Hobby knife with #11 blade
Rotary tool	Sanding drum
Felt-tipped pen	Propeller reamer

□ 1. Locate the items necessary to attach the cowling to the fuselage. The fuselage will also be required for this section of the manual.

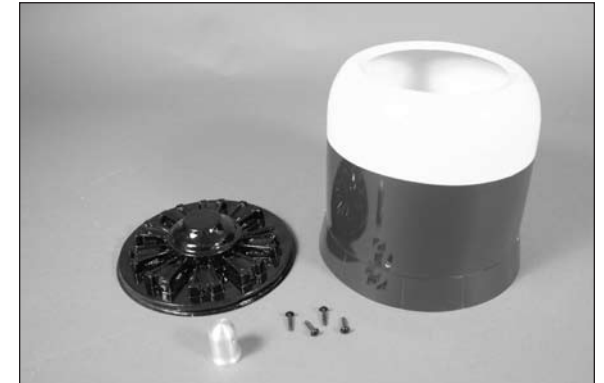

□ 2. Use hobby scissors and a hobby knife with a #11 blade to remove the center from the dummy engine.



□ 3A. (Glow/Gas Only) Remove the area between the cylinders as shown to clear the carburetor on the engine. Choose the section that has the widest gap between cylinders. This will allow you to see the carburetor to position the dummy engine in the cowl. This hole will be enlarged in the following step.



□ 3B. (EP Only) Remove the material between four of the cylinders to allow cooling air to pass over the motor and speed control.



□ 4. Fit the dummy engine over the engine. Trim the dummy engine as necessary so the drive washer is exposed forward of the dummy engine.

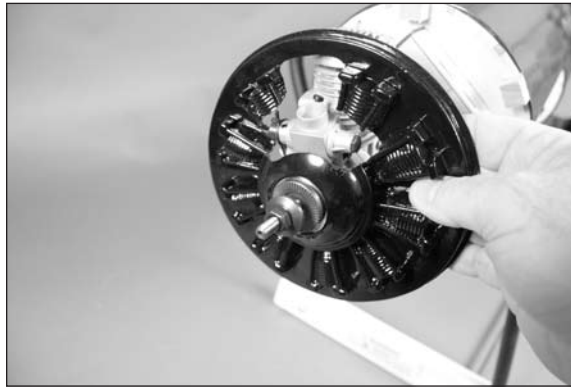

**Note:** It may be necessary to increase the amount of inlet area around the cylinders as needed for each of the engine applications. Too much inlet air will cause pressure inside the cowl and actually cause more heating issues. The goal is to have adequate outlets in the cowling to allow the incoming air to escape.

□ 5. Use a felt-tipped pen to draw a centerline on the four cowl mounting blocks.

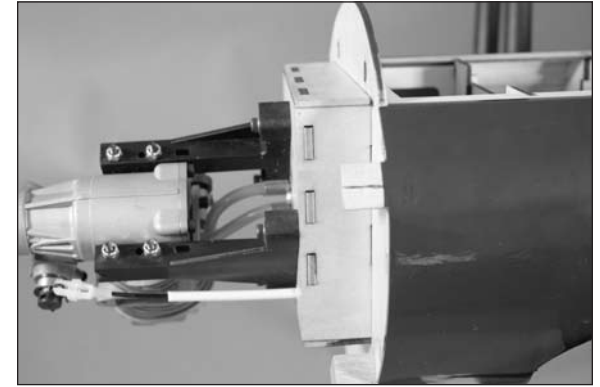

□ 6. Slide the dummy radial into the cowling. Fit the cowling over the engine and on the fuselage. Position the dummy engine so it aligns with the carburetor when the mounting holes in the cowl align with the centerline on the cowl mounting blocks.

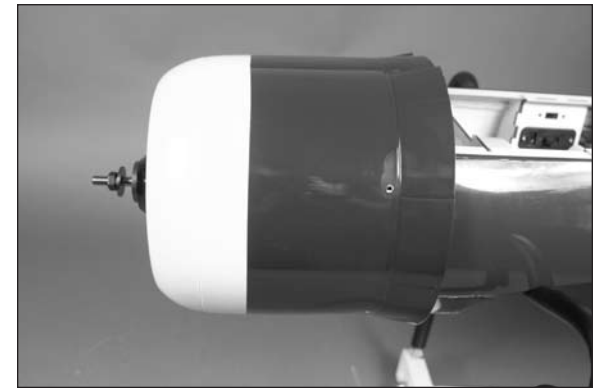

**Note:** The position of the dummy engine does not have to be exact at this time. It can be adjusted once the mounting screws are installed that secure the cowl to the fuselage.

- 7. The lines drawn on the cowl mounting blocks in step 5 are used in aligning the mounting holes of the cowl, centering them on the blocks. Use a felt-tipped pen to mark the locations for the cowl mounting screws on the blocks.

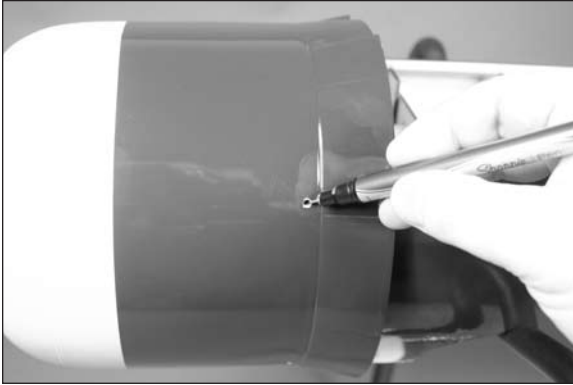

- 8. Use a drill and 5/64-inch (2mm) drill bit to drill the holes for the cowl mounting screws.

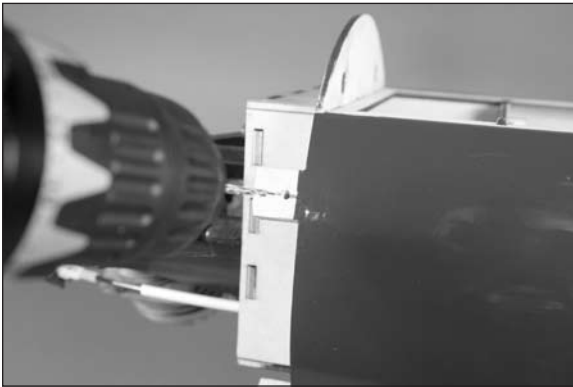

- 9. Use a #1 Phillips screwdriver to run a 3mm x 15mm black washer head screw in the four mounting blocks. Make sure to remove the screw before proceeding to the next step.

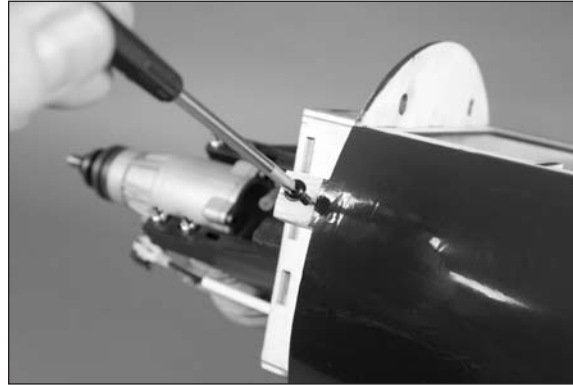

- 10. Apply 2–3 drops of thin CA in each hole drilled. This will harden the surrounding wood, making the screws more secure when installed.

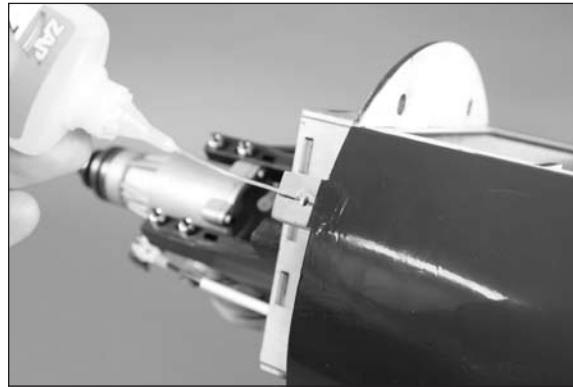

**Important:** Do not use a CA accelerator. Using an accelerator will not allow the CA to soak into the fibers of the wood, hardening the blocks.

- 11. Secure the cowl to the fuselage using four 3mm x 15mm black washer head screws. Use a #1 Phillips screwdriver to tighten the screws. Carefully position the dummy engine so it is in perfect alignment with the carburetor. You may need to trim the opening for the carburetor slightly.

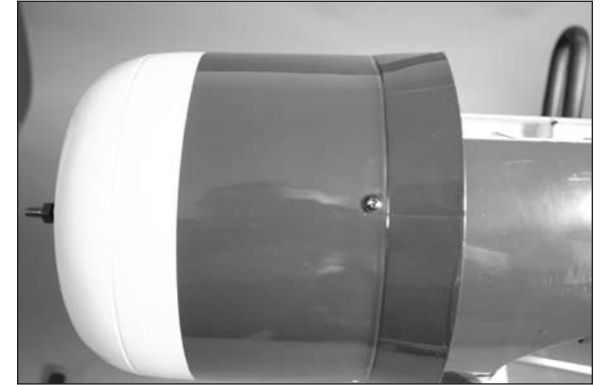

- 12. Carefully remove the cowl. Do not disturb the positioning of the dummy engine. Mark the position of the dummy engine inside the cowl so it can be returned to its original location. Remove the dummy engine and use a flexible silicone adhesive to secure the dummy engine in the cowl.

- 13. (Glow/Gas Only) Attach the muffler to the engine using the hardware provided with the engine. The nut from the muffler will fit in the notch in the fuselage as shown.

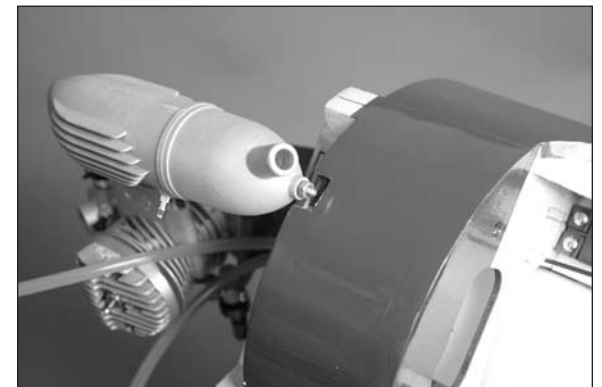

14. (Glow/Gas Only) Connect the fuel lines from the tank to the engine. The line from the vent attaches to the muffler, while the line from the clunk attaches to the carburetor. Fit the cowl over the engine, trimming as necessary to fit over the muffler. Also make an opening for the needle valve so the engine can be tuned without removing the cowl. Make sure to cut the cowl to provide an air outlet for the incoming air that will be cooling the engine.

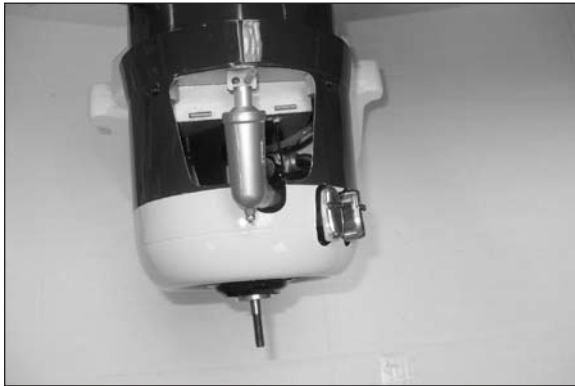
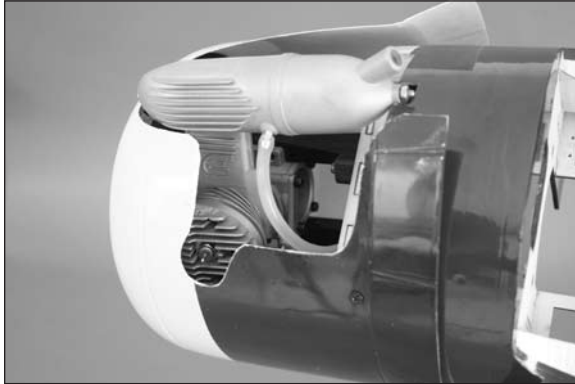

**Note:** We installed a fuel filler to make fueling the model easier with the cowl on.

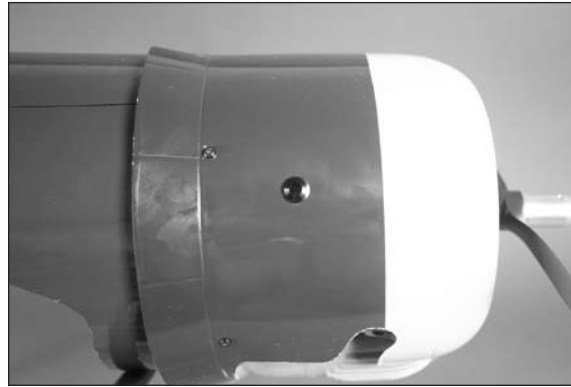

15. Attach the propeller to the engine using the spinner nut. Use a long-handle wrench that fits through the hole in the spinner nut to tighten it securely to the propeller shaft.



**Note:** It may be necessary to use a reamer to enlarge the hole in the propeller to fit the motor shaft. Always balance your propeller. An unbalanced propeller can cause vibrations to be transmitted into the airframe, which could damage the airframe or other components as well as produce unwanted flight characteristics.

## ***Pilot, Canopy and Antenna Mast Installation***

### **Required Parts**

Fuselage assembly	Canopy
Headrest	Antenna mast
Instrument panel decal	Pilot (optional)
Decal sheet	

### **Required Tools and Adhesives**

Low-tack tape	Hobby knife with #11 blade
Hobby scissors	Medium CA
Felt-tipped pen	Medium grit sandpaper
Canopy glue	

1. Locate the items necessary to attach the canopy and antenna mast to the fuselage. The fuselage will also be required for this section of the manual.

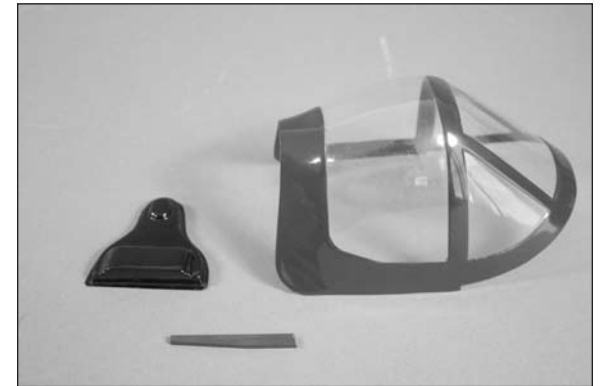

2. Use hobby scissors to remove the flashing from the outside of the headrest.



- 3. Use medium CA to glue the headrest in the cockpit.



- 4. Use a hobby knife with a #11 blade to trim the instrument panel from the decal sheet. Apply the instrument panel decal in the cockpit as shown.



- 5. (Optional) Trim 1/4-inch (6mm) from the bottom of the pilot using a hobby knife with a #11 blade. Use 30-minute epoxy to secure the pilot figure in the cockpit.



- 6. Fit the canopy to the fuselage. The paint line at the rear of the canopy will line up with the edge of the fuselage where the headrest is glued. Use a felt-tipped pen to transfer the outline of the canopy to the fuselage.



- 7. Use medium grit sandpaper to lightly sand a 1/4-inch (6mm) wide strip inside the line drawn in the previous step. This will provide a rough surface for the glue to adhere to when gluing the canopy in position.



- 8. Use medium grit sandpaper to lightly sand a 1/4-inch (6mm) wide strip inside the canopy. This will provide a rough surface for the glue to adhere to when gluing the canopy in position.

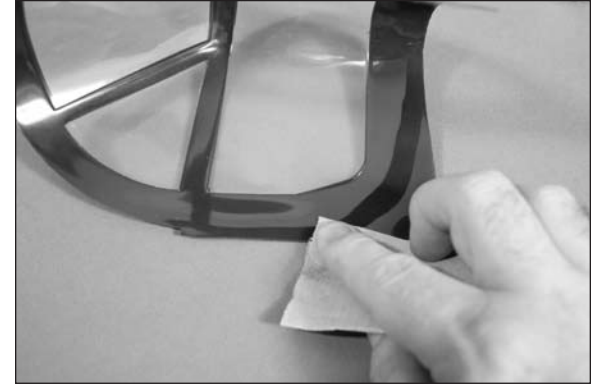

- 9. Use canopy glue to glue the canopy to the fuselage. Use low-tack tape to hold the canopy in position until the glue fully cures.



□ 10. Measure back 2½-inches (63mm) and use a hobby knife with a #11 blade to cut a small opening for the antenna mast. Start small and work up until the mast just fits into the opening.

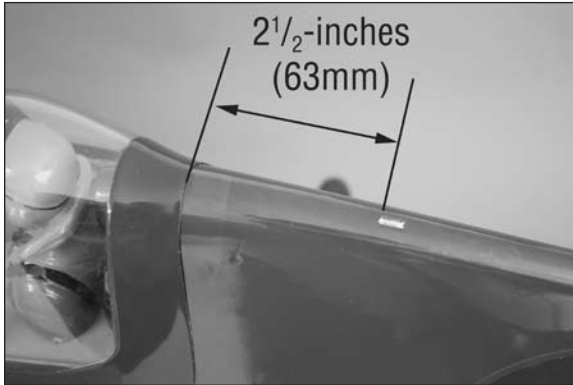

□ 11. Use a hobby knife with a #11 blade to remove the covering 1/8-inch (3mm) from the bottom of the antenna mast so the glue can adhere to the exposed wood.

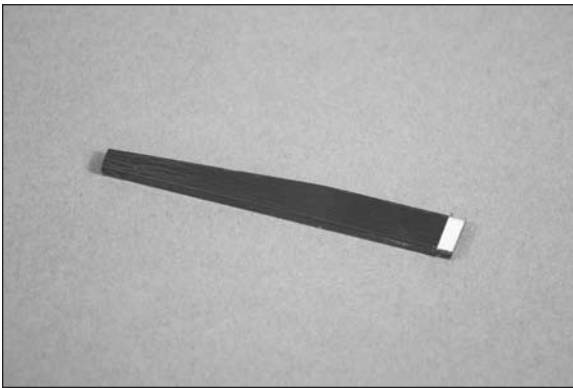

□ 12. Use medium CA to glue the antenna mast to the fuselage.



**Hint:** Sight down the top of the fuselage from the front to make sure the antenna mast is vertical and aligned with the fin. There is nothing worse than a crooked mast.

## Radiator and Gun Installation

### Required Parts

Wing assembly                      Plastic machine gun (2)  
Plastic radiators (right and left)

### Required Tools and Adhesives

Drill                                      Drill bit: 1/4-inch (6mm)  
Low-tack tape                      Hobby knife with #11 blade  
Canopy glue                        Hobby scissors

□ 1. Locate the radiators and guns for installation. You will also require the wing for this section of the manual.



□□ 2. Use a hobby knife with a #11 blade and hobby scissors to remove the flashing from the radiator. Also remove the ends so the radiator can fit to the wing.



**Hint:** Radius the corners to minimize catching an edge when you wipe the model down with a towel.

□□ 3. Test fit the radiator to the wing. Note the direction of the bevels on the radiators: they will angle to the wing tip when installed. Once satisfied with the fit, use canopy glue to secure the radiator to the wing. Hold the radiator in position using low-tack tape until the glue cures.

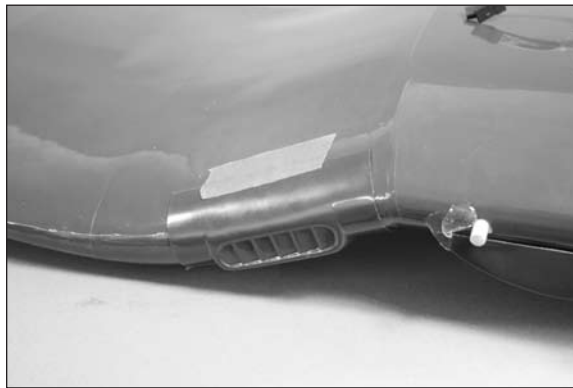
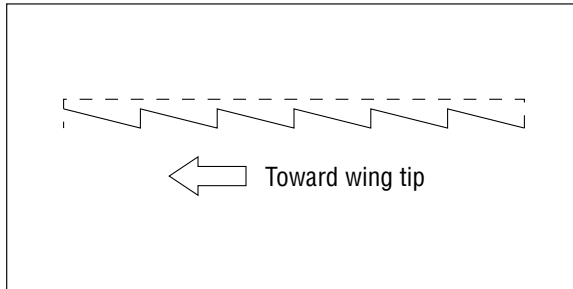

□□ 4. Use a hobby knife with a #11 blade and hobby scissors to remove the flashing from the machine gun. Also remove the ends so the machine can fit to the wing.



**Hint:** Radius the corners to minimize catching an edge when you wipe the model down with a towel.

□□ 5. Measure out 3-inches (76mm) from the edge of the gear mount opening. Use a drill and 1/4-inch (6mm) drill bit to drill a hole in the leading edge of the wing so the indentation of the machine gun can rest in the hole.

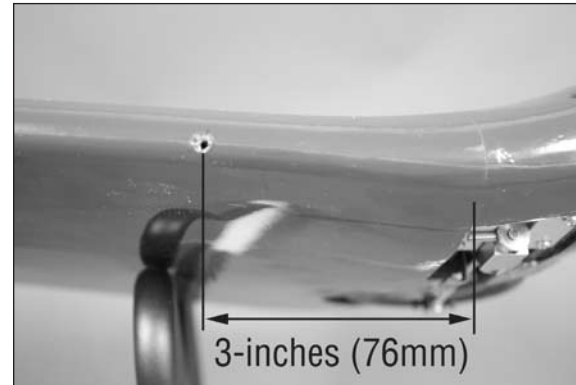

□□ 6. Position the machine gun on the leading edge. The inner-most gun will rest in the hole drilled in the previous step. Press the machine gun against the leading edge to leave marks for the other two machine gun hole locations to drill to fit the machine gun tight against the leading edge.



□□ 7. Use a drill and 1/4-inch (6mm) drill bit to drill the remaining two locations so the machine gun can rest tightly against the leading edge of the wing.



□□ 8. Test fit the machine gun to the wing. You may need to chamfer the holes with a hobby knife and #11 blade slightly to get the machine gun to fit tightly against the wing. Once satisfied with the fit, use canopy glue to secure the machine gun to the wing. Hold the machine gun in position using low-tack tape until the glue cures.

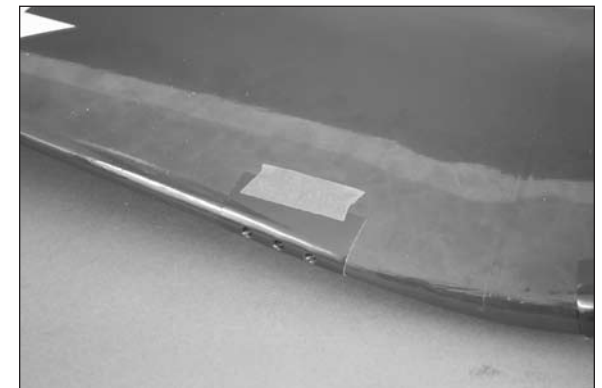

## Decal Installation

### Required Parts

Airframe assembly      Decal

### Required Tools and Adhesives

Spray bottle              Dish washing detergent  
Paper towel                Hobby knife with #11 blade

□ 1. Apply the decals to your model using the photos located in this section of the manual and the box art from your model. Use a spray bottle and a drop of dish washing liquid or glass cleaner sprayed in the location of the decal to allow repositioning of the decal. Use a paper towel as a squeegee to remove excess water from under the decal. Allow the model to rest overnight so the remaining water can evaporate.

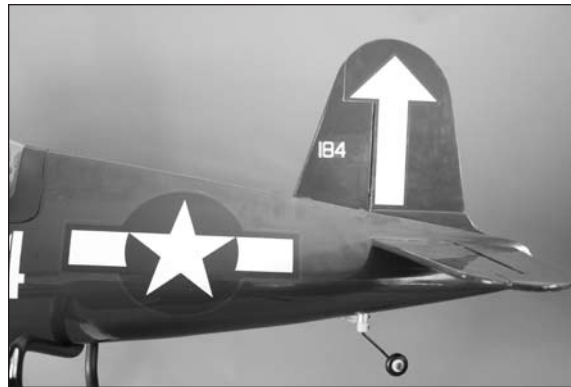

□ 2. When applying the fuel tank decal, we recommend removing as much of the inner clear section of the decal as possible so it can be formed to the curvature of the fuselage. If not trimmed, the decal will wrinkle and not lay flat on the fuselage.

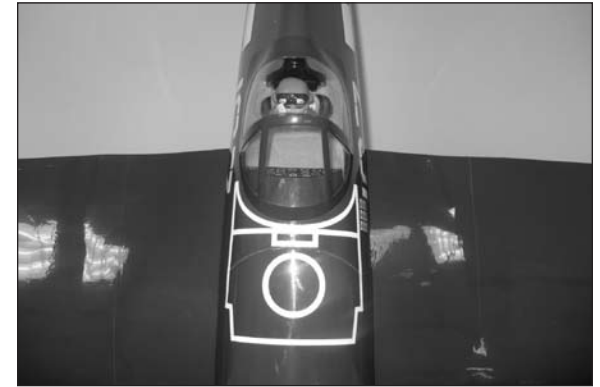



## Center of Gravity

### Required Parts

Assembled wing      Assembled fuselage  
8-32 x 1 $\frac{1}{4}$ -inch socket head cap screw (2)  
(installed in wing)

### Required Tools and Adhesives

Hex wrench: 9/64-inch      Ruler  
Felt-tipped pen      Balancing stand (optional)

An important part of preparing the aircraft for flight is properly balancing the model.



**CAUTION: Do not inadvertently skip this step!**

1. Attach the wing to the fuselage using the two 8-32 wing bolts and a 9/64-inch hex wrench. Make sure to connect the leads from the aileron (and retracts) to the appropriate leads from the receiver. Make sure the leads are not exposed outside the fuselage before tightening the wing bolts.

2. The recommended Center of Gravity (CG) location for your model is 4 inches (102mm) back from the leading edge of the wing as shown. Mark the location of the CG on the top of the wing with a felt-tipped pen.

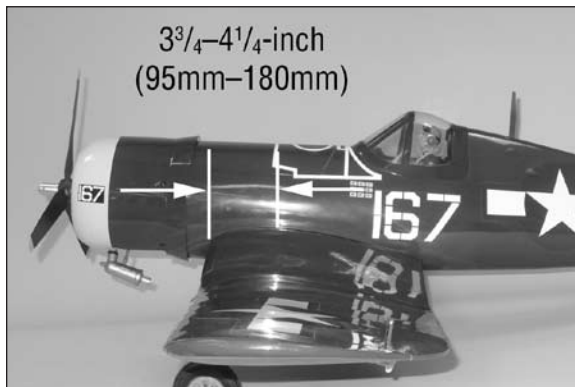

3. When balancing your model, make sure it is assembled and ready for flight. Support the plane inverted at the marks made on the wing with your fingers or a commercially available balancing stand. This is the correct balance point for your model.

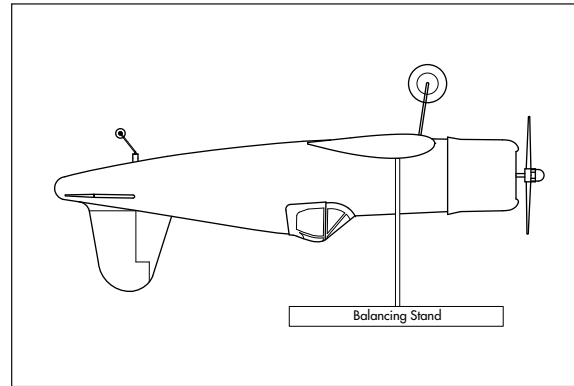

4. You should find the CG to be very close with the components installed as shown in this manual. If the nose of your aircraft hangs low, add weight to the rear of the aircraft. If the tail hangs low, add weight to the nose of the aircraft. Stick-on weights are available at your local hobby store and work well for this purpose.

After the first flights, the CG position can be adjusted for your personal preference. We have found the Corsair 50 to balance anywhere between 3 $\frac{3}{4}$ –4 $\frac{1}{4}$ -inch (95mm–180mm) while maintaining its great flying characteristics.

## Control Throws

1. Turn on the transmitter and receiver of your model. Check the movement of the rudder using the transmitter. When the stick is moved right, the rudder should also move right. Reverse the direction of the servo at the transmitter if necessary.

2. Check the movement of the elevator with the radio system. Moving the elevator stick toward the bottom of the transmitter will make the airplane elevator move up.

3. Check the movement of the ailerons with the radio system. Moving the aileron stick right will make the right aileron move up and the left aileron move down.

4. Use a ruler to adjust the throw of the elevator, ailerons and rudder.

### Aileron:

#### High Rate:

Up:	5/8-inches	16mm
Down:	1/2-inches	13mm

#### Low Rate:

Up:	3/8-inches	10mm
Down:	5/16-inches	8mm

### Elevator:

#### High Rate:

Up:	9/16-inches	14mm
Down:	9/16-inches	14mm

#### Low Rate:

Up:	5/16-inches	8mm
Down:	5/16-inches	8mm

### Rudder:

#### High Rate:

Right:	2 $\frac{1}{4}$ -inches	57mm
Left:	2 $\frac{1}{4}$ -inches	57mm

#### Low Rate:

Right:	1 $\frac{1}{4}$ -inches	32mm
Left:	1 $\frac{1}{4}$ -inches	32mm

These are general guidelines measured from our own flight tests. You can experiment with higher rates to match your preferred style of flying.

**Note:** Travel Adjust and Sub-Trims are not listed and should be adjusted according to each individual model and preference. Always install the control horns 90-degrees to the servo centerline. Use sub-trim as a last resort to center the servos.

**Note:** We highly recommend re-binding the radio system once all the control throws are set. This will keep the servos from moving to their endpoints until the transmitter and receiver connect.

## ***Preflight***

---

### **Check Your Radio**

Before going to the field, be sure your batteries are fully charged per your radio's instructions. Charge the transmitter and motor battery for your airplane. Use the recommended charger supplied with your particular radio system, following the instructions provided with the radio. In most cases, the radio should be charged the night before going out flying.

Before each flying session, be sure to range check your radio. See your radio manual for the recommended range and instructions for your radio system. Each radio manufacturer specifies different procedures for their radio systems. Next, run the motor. With the model securely anchored, check the range again. The range test should not be significantly affected. If it is, don't attempt to fly! Have your radio equipment checked out by the manufacturer.

Double-check that all controls (aileron, elevator, rudder and throttle) move in the correct direction.

Check the radio installation and make sure all the control surfaces are moving correctly (i.e., the correct direction and with the recommended throws).

Check all the control horns, servo horns, and clevises to make sure they are secure and in good condition.

### ***Range Test Your Radio***

---

Before each flying session, and especially with a new model, it is important to perform a range check. It is helpful to have another person available to assist during the range check. If you are using a Spektrum transmitter, please refer to your transmitter's manual for detailed instructions on the range check process.

## ***Safety Do's and Don'ts for Pilots***

---

- Consult local laws and ordinances before choosing a location to fly your aircraft.
- Check all control surfaces prior to each takeoff.
- Do not fly your model near spectators, parking areas or any other area that could result in injury to people or damage of property.
- Do not fly during adverse weather conditions. Poor visibility can cause disorientation and loss of control of your aircraft. Strong winds can cause similar problems.
- Do not take chances. If at any time during flight you observe any erratic or abnormal operation, land immediately and do not resume flight until the cause of the problem has been ascertained and corrected. Safety can never be taken lightly.
- Do not fly near power lines.

### ***Daily Flight Checks***

---

- 1. Check the battery voltage of the transmitter battery. Do not fly below the manufacturer's recommended voltage. To do so can crash your aircraft.

**When you check these batteries, ensure you have the polarities correct on your expanded scale voltmeter.**

- 2. Check all hardware (linkages, screws, nuts, and bolts) prior to each day's flight. Be sure that binding does not occur and that all parts are properly secured.
- 3. Ensure all surfaces are moving in the proper manner.
- 4. Perform a ground range check before each day's flying session.
- 5. Prior to starting your aircraft, turn off your transmitter, then turn it back on. Do this each time you start your aircraft. If any critical switches are on without your knowledge, the transmitter alarm will sound a warning at this time.
- 6. Check that all trim levers are in the proper location.
- 7. All servo pigtails and switch harness plugs should be secured in the receiver. Make sure the switch harness moves freely in both directions.

## Warranty and Repair Policy

### WARRANTY PERIOD

Exclusive Warranty- Horizon Hobby, Inc., (Horizon) warranties that the Products purchased (the "Product") will be free from defects in materials and workmanship at the date of purchase by the Purchaser.

### LIMITED WARRANTY

**Horizon reserves the right to change or modify this warranty without notice and disclaims all other warranties, express or implied.**

(a) This warranty is limited to the original Purchaser ("Purchaser") and is not transferable. REPAIR OR REPLACEMENT AS PROVIDED UNDER THIS WARRANTY IS THE EXCLUSIVE REMEDY OF THE PURCHASER. This warranty covers only those Products purchased from an authorized Horizon dealer. Third party transactions are not covered by this warranty. Proof of purchase is required for all warranty claims.

(b) Limitations- HORIZON MAKES NO WARRANTY OR REPRESENTATION, EXPRESS OR IMPLIED, ABOUT NON-INFRINGEMENT, MERCHANTABILITY OR FITNESS FOR A PARTICULAR PURPOSE OF THE PRODUCT. THE PURCHASER ACKNOWLEDGES THAT THEY ALONE HAVE DETERMINED THAT THE PRODUCT WILL SUITABLY MEET THE REQUIREMENTS OF THE PURCHASER'S INTENDED USE.

(c) Purchaser Remedy- Horizon's sole obligation hereunder shall be that Horizon will, at its option, (i) repair or (ii) replace, any Product determined by Horizon to be defective. In the event of a defect, these are the Purchaser's exclusive remedies. Horizon reserves the right to inspect any and all equipment involved in a warranty claim. Repair or replacement decisions are at the sole discretion of Horizon. This warranty does not cover cosmetic damage or damage due to acts of God, accident, misuse, abuse, negligence, commercial use, or modification of or to any part of the Product. This warranty does not cover damage due to improper installation, operation, maintenance, or attempted repair by anyone other than Horizon. Return of any Product by Purchaser must be approved in writing by Horizon before shipment.

### DAMAGE LIMITS

HORIZON SHALL NOT BE LIABLE FOR SPECIAL, INDIRECT OR CONSEQUENTIAL DAMAGES, LOSS OF PROFITS OR PRODUCTION OR COMMERCIAL LOSS IN ANY WAY CONNECTED WITH THE PRODUCT, WHETHER SUCH CLAIM IS BASED IN CONTRACT, WARRANTY, NEGLIGENCE, OR STRICT LIABILITY. Further, in no event shall the liability of Horizon exceed the individual price of the Product on which liability is asserted. As Horizon has no control over use, setup, final assembly, modification or misuse, no liability shall be assumed nor accepted for any resulting damage or injury. By the act of use, setup or assembly, the user accepts all resulting liability.

If you as the Purchaser or user are not prepared to accept the liability associated with the use of this Product, you are advised to return this Product immediately in new and unused condition to the place of purchase.

Law: These Terms are governed by Illinois law (without regard to conflict of law principals).

## Warranty Services

### QUESTIONS, ASSISTANCE, AND REPAIRS

Your local hobby store and/or place of purchase cannot provide warranty support or repair. Once assembly, setup or use of the Product has been started, you must contact Horizon directly. This will enable Horizon to better answer your questions and service you in the event that you may need any assistance. For questions or assistance, please direct your email to [productsupport@horizonhobby.com](mailto:productsupport@horizonhobby.com), or call 877.504.0233 toll free to speak to a Product Support representative. You may also find information on our website at [www.horizonhobby.com](http://www.horizonhobby.com).

### INSPECTION OR REPAIRS

If this Product needs to be inspected or repaired, please use the Horizon Online Repair Request submission process found on our website or call Horizon to obtain a Return Merchandise Authorization (RMA) number. Pack the Product securely using a shipping carton. Please note that original boxes may be included, but are not designed to withstand the rigors of shipping without additional protection. Ship via a carrier that provides tracking and insurance for lost or damaged parcels, as Horizon is not responsible for merchandise until it arrives and is accepted at our facility. An Online Repair Request is available at [www.horizonhobby.com](http://www.horizonhobby.com) under the Repairs tab. If you do not have internet access, please contact Horizon Product Support to obtain a RMA number along with instructions for submitting your product for repair. When calling Horizon, you will be asked to provide your complete name, street address, email address and phone number where you can be reached during business hours. When sending product into Horizon, please include your RMA number, a list of the included items, and a brief summary of the problem. A copy of your original sales receipt must be included for warranty consideration. Be sure your name, address, and RMA number are clearly written on the outside of the shipping carton.

**Notice: Do not ship batteries to Horizon. If you have any issue with a battery, please contact the appropriate Horizon Product Support office.**

## WARRANTY INSPECTION AND REPAIRS

To receive warranty service, you must include your **original sales receipt** verifying the proof-of-purchase date. Provided warranty conditions have been met, your Product will be repaired or replaced free of charge. Repair or replacement decisions are at the sole discretion of Horizon.

## NON-WARRANTY REPAIRS

**Should your repair not be covered by warranty the repair will be completed and payment will be required without notification or estimate of the expense unless the expense exceeds 50% of the retail purchase cost.** By submitting the item for repair you are agreeing to payment of the repair without notification. Repair estimates are available upon request. You must include this request with your repair. Non-warranty repair estimates will be billed a minimum of ½ hour of labor. In addition you will be billed for return freight. Horizon accepts money orders and cashiers checks, as well as Visa, MasterCard, American Express, and Discover cards. By submitting any item to Horizon for inspection or repair, you are agreeing to Horizon's Terms and Conditions found on our website under the Repairs tab.

## UNITED STATES

*(Electronics and engines)*

Horizon Service Center  
4105 Fieldstone Rd  
Champaign, Illinois  
61822 USA  
productsupport@horizonhobby.com  
877-504-0233  
Online Repair Request visit:  
www.horizonhobby.com/repairs

*(All other products)*

Horizon Product Support  
4105 Fieldstone Rd  
Champaign, Illinois  
61822 USA  
productsupport@horizonhobby.com  
877-504-0233

## UNITED KINGDOM

Horizon Hobby Limited  
Units 1-4 Ployters Rd  
Staple Tye  
Harlow, Essex  
CM18 7NS  
United Kingdom  
sales@horizonhobby.co.uk  
+44 (0) 1279 641 097

## GERMANY

Horizon Technischer Service  
Hamburger Str. 10  
25335 Elmshorn  
Germany  
service@horizonhobby.de  
+49 4121 46199 66

## FRANCE

Horizon Hobby SAS  
14 Rue Gustave Eiffel  
Zone d'Activité du Réveil Matin  
91230 Montgeron  
infofrance@horizonhobby.com  
+33 (0) 1 60 47 44 70

## Compliance Information for the European Union



### INSTRUCTIONS FOR DISPOSAL OF WEEE BY USERS IN THE EUROPEAN UNION

This product must not be disposed of with other waste. Instead, it is the user's responsibility to dispose of their waste equipment by handing it over to a designated collection point for the recycling of waste electrical and electronic equipment. The separate collection and recycling of your waste equipment at the time of disposal will help to conserve natural resources and ensure that it is recycled in a manner that protects human health and the environment. For more information about where you can drop off your waste equipment for recycling, please contact your local city office, your household waste disposal service or where you purchased the product.

## Academy of Model Aeronautics National Model Aircraft Safety Code

Effective January 1, 2011

### A. GENERAL

A model aircraft is a non-human-carrying aircraft capable of sustained flight in the atmosphere. It may not exceed limitations of this code and is intended exclusively for sport, recreation and/or competition. All model flights must be conducted in accordance with this safety code and any additional rules specific to the flying site.

1. Model aircraft will not be flown:
    - (a) In a careless or reckless manner.
    - (b) At a location where model aircraft activities are prohibited.
  2. Model aircraft pilots will:
    - (a) Yield the right of way to all man carrying aircraft.
    - (b) See and avoid all aircraft and a spotter must be used when appropriate. (AMA Document #540-D-See and Avoid Guidance.)
    - (c) Not fly higher than approximately 400 feet above ground level within three (3) miles of an airport, without notifying the airport operator.
    - (d) Not interfere with operations and traffic patterns at any airport, heliport or seaplane base except where there is a mixed use agreement.
    - (e) Not exceed a takeoff weight, including fuel, of 55 pounds unless in compliance with the AMA Large Model Aircraft program. (AMA Document 520-A)
    - (f) Ensure the aircraft is identified with the name and address or AMA number of the owner on the inside or affixed to the outside of the model aircraft. (This does not apply to model aircraft flown indoors).
    - (g) Not operate aircraft with metal-blade propellers or with gaseous boosts except for helicopters operated under the provisions of AMA Document #555.
    - (h) Not operate model aircraft while under the influence of alcohol or while using any drug which could adversely affect the pilot's ability to safely control the model.
    - (i) Not operate model aircraft carrying pyrotechnic devices which explode or burn, or any device which propels a projectile or drops any object that creates a hazard to persons or property.
- Exceptions:
- Free Flight fuses or devices that burn producing smoke and are securely attached to the model aircraft during flight.

- Rocket motors (using solid propellant) up to a G-series size may be used provided they remain attached to the model during flight. Model rockets may be flown in accordance with the National Model Rocketry Safety Code but may not be launched from model aircraft.
  - Officially designated AMA Air Show Teams (AST) are authorized to use devices and practices as defined within the Team AMA Program Document (AMA Document #718).
    - (j) Not operate a turbine-powered aircraft, unless in compliance with the AMA turbine regulations. (AMA Document #510-A).
3. Model aircraft will not be flown in AMA sanctioned events, air shows or model demonstrations unless:
    - (a) The aircraft, control system and pilot skills have successfully demonstrated all maneuvers intended or anticipated prior to the specific event.
    - (b) An inexperienced pilot is assisted by an experienced pilot.
  4. When and where required by rule, helmets must be properly worn and fastened. They must be OSHA, DOT, ANSI, SNELL or NOCSAE approved or comply with comparable standards.

## **B. RADIO CONTROL (RC)**

1. All pilots shall avoid flying directly over unprotected people, vessels, vehicles or structures and shall avoid endangerment of life and property of others.
2. A successful radio equipment ground-range check in accordance with manufacturer's recommendations will be completed before the first flight of a new or repaired model aircraft.
3. At all flying sites a safety line(s) must be established in front of which all flying takes place (AMA Document #706-Recommended Field Layout):
  - (a) Only personnel associated with flying the model aircraft are allowed at or in front of the safety line.
  - (b) At air shows or demonstrations, a straight safety line must be established.
  - (c) An area away from the safety line must be maintained for spectators.
  - (d) Intentional flying behind the safety line is prohibited.
4. RC model aircraft must use the radio-control frequencies currently allowed by the Federal Communications Commission (FCC). Only individuals properly licensed by the FCC are authorized to operate equipment on Amateur Band frequencies.
5. RC model aircraft will not operate within three (3) miles of any pre-existing flying site without a frequency-management agreement (AMA Documents #922- Testing for RF Interference; #923- Frequency Management Agreement)

6. With the exception of events flown under official AMA Competition Regulations, excluding takeoff and landing, no powered model may be flown outdoors closer than 25 feet to any individual, except for the pilot and the pilot's helper(s) located at the flight line.
7. Under no circumstances may a pilot or other person touch a model aircraft in flight while it is still under power, except to divert it from striking an individual. This does not apply to model aircraft flown indoors.
8. RC night flying requires a lighting system providing the pilot with a clear view of the model's attitude and orientation at all times.
9. The pilot of a RC model aircraft shall:
  - (a) Maintain control during the entire flight, maintaining visual contact without enhancement other than by corrective lenses prescribed for the pilot.
  - (b) Fly using the assistance of a camera or First-Person View (FPV) only in accordance with the procedures outlined in AMA Document #550.

## **C. FREE FLIGHT**

1. Must be at least 100 feet downwind of spectators and automobile parking when the model aircraft is launched.
2. Launch area must be clear of all individuals except mechanics, officials, and other fliers.
3. An effective device will be used to extinguish any fuse on the model aircraft after the fuse has completed its function.

## **D. CONTROL LINE**

1. The complete control system (including the safety thong where applicable) must have an inspection and pull test prior to flying.
2. The pull test will be in accordance with the current Competition Regulations for the applicable model aircraft category.
3. Model aircraft not fitting a specific category shall use those pull-test requirements as indicated for Control Line Precision Aerobatics.
4. The flying area must be clear of all utility wires or poles and a model aircraft will not be flown closer than 50 feet to any above-ground electric utility lines.
5. The flying area must be clear of all nonessential participants and spectators before the engine is started.

## ***Building and Flying Notes***

---

---

---

---

---

---

---

---

---

---

---

---

---

---

---

---

---

---

---

---

---

---

---

---

---

---





© 2011 Horizon Hobby, Inc.  
horizonhobby.com  
Hangar9.com

*The Spektrum trademark is used with permission  
of Bachmann Industries, Inc.  
All other marks are trademarks or registered  
trademarks of Horizon Hobby, Inc.*