

Name: Frank Root *Frank Root* Date: 10-21-2012 Event: SC Showdown

City: Carrollton State: Texas Track: Mike's Hobby Shop

Track Conditions: Indoor Tight Smooth Hard Packed Blue Groove Wet Grass Low Bite High Bite
 Outdoor Open Rough Loose/Loamy Dry Dusty Astro Turf Med Bite Other _____

Front Suspension

Toe: +/- 0
 Ride Height: 29mm
 Camber: -1 degree
 Caster: 0° 3° 5° 10°
 Kick Angle: 20° 25° 30°
 Sway Bar: none
 Shock Type: Bladder Emulsion Oil: 30wt. Losi
 Piston: 2x 1.6mm
 Spring: Black (TLR5184)
 Shock Limiters: 1mm
 Shock Location: 1-outside
 Bump Steer: 0mm
 Camber Link: 2

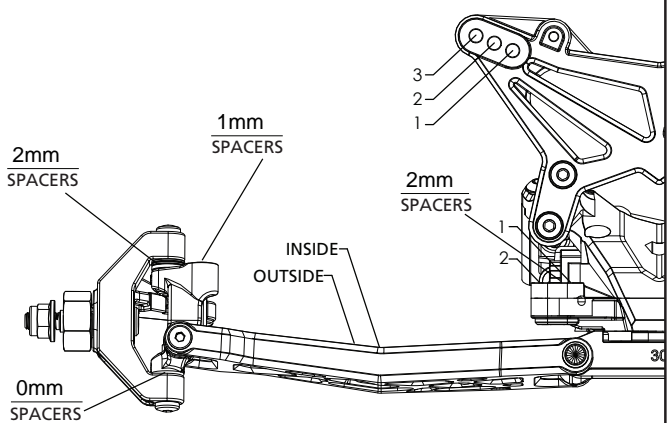

Notes: Alum front pivot (TLR1072) and Alum front camber block (TLR2062)

Rear Suspension

Chassis Configuration: Rear Motor Mid Motor
 Differential: Ball Diff Gear Diff Gear Diff Fluid: Tight
 Toe: 3.0 LRC
 Anti-Squat: 2.0 LRC
 Roll Center: Low Roll Center (LRC) High Roll Center (HRC)
 Ride Height: 28mm
 Camber: -1 degree
 Rear Hub Spacing: 1mm front, 3mm rear
 Hex Width: Stock
 Sway Bar: none
 Shock Type: Bladder Emulsion Oil: 30wt. Losi
 Piston: 2x 1.6mm
 Spring: Buggy Yellow (TLR5167)
 Shock Limiters: 2mm
 Camber Link: 1-C
 Shock Locations: 1-inside
 Battery Position: 1 pad fr., WTS-cells forward, alum, brass, 3 pads

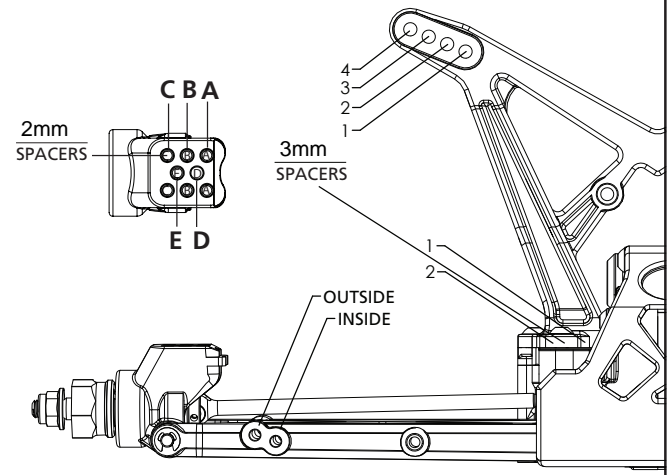

Electronics
 Radio: DX3R Pro Timing Advance: 0
 Servo: SPMSS6040 Throttle/Brake Expo: 0
 ESC: Orion R10 Pro Servo Expo: 0
 Initial Brake: Drag Br. Throttle/Brake EPA: 100/75
 Drag Brake: 12% Motor: Orion VST 6.5T
 Throttle Profile: 5 Pinion: 16 Spur: 86
 Battery: Orion WTS

Weight Placement (Mark with "X")

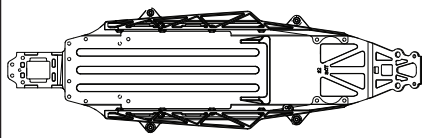

Tires	Compound	Insert	Additive
Front: <u>JC Pressure Points</u>	<u>Blue</u>	<u>Stock</u>	<u>Kinwald Sauce</u>
Rear: <u>JC Pressure Points</u>	<u>Blue</u>	<u>Stock</u>	<u>Kinwald Sauce</u>

Weight of each piece _____ oz./g

Notes: 3oz. of weight in front of rear pivot, alum rear camber block (TLR2060)