

**RTR**  
READY-TO-RUN

# 1972 CHEVY® SUBURBAN ASCENDER®



## OWNER'S MANUAL

BEDIENUNGSANLEITUNG  
MANUEL DE L'UTILISATEUR  
MANUALE DELL'UTENTE



**VATERRA®**

Before operating this vehicle, please read all printed materials thoroughly.  
Horizon Hobby is not responsible for inadvertent errors in this manual.

**NOTICE**

All instructions, warranties and other collateral documents are subject to change at the sole discretion of Horizon Hobby, LLC. For up-to-date product literature, visit horizonhobby.com and click on the support tab for this product.

**MEANING OF SPECIAL LANGUAGE**

The following terms are used throughout the product literature to indicate various levels of potential harm when operating this product:

**WARNING:** Procedures, which if not properly followed, create the probability of property damage, collateral damage, and serious injury OR create a high probability of superficial injury.

**CAUTION:** Procedures, which if not properly followed, create the probability of physical property damage AND a possibility of serious injury.

**NOTICE:** Procedures, which if not properly followed, create a possibility of physical property damage AND a little or no possibility of injury.

**WARNING:** Read the ENTIRE instruction manual to become familiar with the features of the product before operating. Failure to operate the product correctly can result in damage to the product, personal property and cause serious injury.

This is a sophisticated hobby product. It must be operated with caution and common sense and requires some basic mechanical ability. Failure to operate this Product in a safe and responsible manner could result in injury or damage to the product or other property. This product is not intended for use by children without direct adult supervision. Do not use with incompatible components or alter this product in any way outside of the instructions provided by Horizon Hobby, LLC. This manual contains instructions for safety, operation and maintenance. It is essential to read and follow all the instructions and warnings in the manual, prior to assembly, setup or use, in order to operate correctly and avoid damage or serious injury.

**WARNING AGAINST COUNTERFEIT PRODUCTS** Always purchase from a Horizon Hobby, LLC authorized dealer to ensure authentic high-quality Spektrum product. Horizon Hobby, LLC disclaims all support and warranty with regards, but not limited to, compatibility and performance of counterfeit products or products claiming compatibility with DSM® or Spektrum technology.

**Age Recommendation: Not for children under 14 years. This is not a toy.**

**SAFETY PRECAUTIONS AND WARNINGS**

As the user of this product, you are solely responsible for operating in a manner that does not endanger yourself and others or result in damage to the product or property of others.

This model is controlled by a radio signal subject to interference from many sources outside your control. This interference can cause momentary loss of control, so it is advisable to always keep a safe distance in all directions around your model as this margin will help avoid collisions or injury.

- » Never operate your model with low transmitter batteries.
- » Always operate your model in open spaces away from full-size vehicles, traffic and people.
- » Never operate the model in the street or in populated areas for any reason.
- » Carefully follow the directions and warnings for this and any optional support equipment (chargers, rechargeable battery packs, etc.) you use.

- » Keep all chemicals, small parts and anything electrical out of the reach of children.
- » Never lick or place any portion of the model in your mouth as it could cause serious injury or even death.
- » Exercise caution when using tools and sharp instruments.
- » Take care during maintenance as some parts may have sharp edges.
- » Immediately after using your model, do NOT touch equipment such as the motor, electronic speed control and battery, because they generate high temperatures. You may burn yourself seriously touching them.
- » Do not put fingers or any objects inside rotating and moving parts, as this may cause damage or serious injury.
- » Always turn on your transmitter before you turn on the receiver in the car. Always turn off the receiver before turning your transmitter off.
- » Keep the wheels of the model off the ground when checking the operation of the radio equipment.

**TABLE OF CONTENTS**

CONTENTS .....2

WATER-RESISTANT VEHICLE WITH WATERPROOF ELECTRONICS.....3

QUICK START .....3

CHARGING THE BATTERY .....3

INSTALLING THE BATTERY .....4

TRANSMITTER CONTROLS .....4

INSTALLING TRANSMITTER BATTERIES .....4

BINDING YOUR TRANSMITTER AND RECEIVER .....4

DRIVING PRECAUTIONS .....5

POWERING ON THE VEHICLE.....5

BEFORE RUNNING YOUR VEHICLE.....5

RUN TIME .....5

PERFORMING A CONTROL DIRECTION TEST .....6

DYNAMITE 60A BRUSHED WATERPROOF ESC .....6

DYNAMITE 540 BRUSHED MOTOR 35T .....7

TROUBLESHOOTING GUIDE .....7

LIMITED WARRANTY .....8

    FCC INFORMATION .....9

    IC INFORMATION.....9

    WARRANTY AND SERVICE CONTACT INFORMATION .....9

EU COMPLIANCE STATEMENT .....9

REPLACEMENT PARTS ..... 31-32

OPTIONAL PARTS ..... 32

EXPLODED VIEWS ..... 33-39

**CONTENTS**

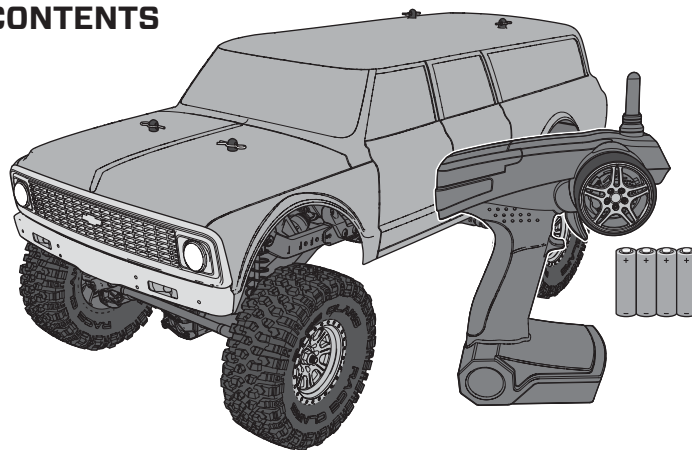

**REGISTER YOUR VATERRA PRODUCT ONLINE**

Register your vehicle now and be the first to find out about the latest option parts, product updates and more. Click on the Support tab at [WWW.VATERRARC.COM](http://WWW.VATERRARC.COM) and follow the product registration link to stay connected.

**COMPONENTS**

- » Vatterra® 1972 Chevy® Suburban Ascender® 4WD RTR (VTR03094)
- » 2.4 GHz 2-Channel Transmitter (AA batteries) (ECX13008)
- » 2-Channel Waterproof Surface Receiver (ECX13009)
- » Spektrum™ 9KG 23T Waterproof Servo (SPMS605)
- » Dynamite® 60A Brushed Waterproof ESC (DYNS2210)
- » Dynamite® 540 Brushed Motor 35T (DYNS1216)

**NEEDED TO COMPLETE**

- » Battery
- » Battery Charger

(see **CHARGING THE BATTERY** section on page 3 for recommendations)

## WATER-RESISTANT VEHICLE WITH WATERPROOF ELECTRONICS //

Your new Horizon Hobby vehicle has been designed and built with a combination of waterproof and water-resistant components to allow you to operate the product in many “wet conditions,” including puddles, creeks, wet grass, snow and even rain.

While the entire vehicle is highly water-resistant, it is not completely waterproof and your vehicle should NOT be treated like a submarine. The various electronic components used in the vehicle, such as the Electronic Speed Control (ESC), servo(s) and receiver are waterproof, however, most of the mechanical components are water-resistant and should not be submerged.

Metal parts, including the bearings, hinge pins, screws and nuts, as well as the contacts in the electrical cables, will be susceptible to corrosion if additional maintenance is not performed after running in wet conditions. To maximize the long-term performance of your vehicle and to keep the warranty intact, the procedures described in the “Wet Conditions Maintenance” section below must be performed regularly if you choose to run in wet conditions. If you are not willing to perform the additional care and maintenance required, then you should not operate the vehicle in those conditions.

**CAUTION:** Failure to exercise caution while using this product and complying with the following precautions could result in product malfunction and/or void the warranty.

### GENERAL PRECAUTIONS

- » Read through the wet conditions maintenance procedures and make sure that you have all the tools you will need to properly maintain your vehicle.
- » Not all batteries can be used in wet conditions. Consult the battery manufacturer before use. Caution should be taken when using Li-Po batteries in wet conditions.
- » Most transmitters are not water-resistant. Consult your transmitter’s manual or the manufacturer before operation.
- » Never operate your transmitter or vehicle where lightning may be present.
- » Do not operate your vehicle where it could come in contact with salt water (ocean water or water on salt-covered roads), contaminated or polluted water. Salt water is very conductive and highly corrosive, so use caution.
- » Even minimal water contact can reduce the life of your motor if it has not been certified as water-resistant or waterproof. If the motor

becomes excessively wet, apply very light throttle until the water is mostly removed from the motor. Running a wet motor at high speeds may rapidly damage the motor.

- » Driving in wet conditions can reduce the life of the motor. The additional resistance of operating in water causes excess strain. Alter the gear ratio by using a smaller pinion or larger spur gear. This will increase torque (and motor life) when running in mud, deeper puddles, or any wet conditions that will increase the load on the motor for an extended period of time.

### WET CONDITIONS MAINTENANCE

- » Drain any water that has collected in the tires by spinning them at high speed. With the body removed, place the vehicle upside down and pull full throttle for a few short bursts until the water has been removed.

**CAUTION:** Always keep hands, fingers, tools and any loose or hanging objects away from rotating parts when performing the above drying technique.

- » Remove the battery pack(s) and dry the contacts. If you have an air compressor or a can of compressed air, blow out any water that may be inside the recessed connector housing.
- » Remove the tires/wheels from the vehicle and gently rinse the mud and dirt off with a garden hose. Avoid rinsing the bearings and transmission.

**NOTICE:** Never use a pressure washer to clean your vehicle.

- » Use an air compressor or a can of compressed air to dry the vehicle and help remove any water that may have gotten into small crevices or corners.
- » Spray the bearings, drive train, fasteners and other metal parts with a water-displacing light oil. Do not spray the motor.
- » Let the vehicle air dry before you store it. Water (and oil) may continue to drip for a few hours.
- » Increase the frequency of disassembly, inspection and lubrication of the following:
  - Front and rear axle hub assembly bearings.
  - All transmission cases, gears and differentials.
  - Motor—clean with an aerosol motor cleaner and re-oil the bushings with lightweight motor oil.

## QUICK START //

Please read the entire manual to gain a full understanding of the Chevy Suburban Ascender, fine-tuning the setup and performing maintenance.

1. Read the safety precautions found in this manual.
2. Charge a battery for the vehicle. Refer to the included charging warnings and instructions for battery charging information.
3. Install the AA batteries in the transmitter. Only use alkaline or rechargeable batteries.
4. Install the fully charged battery in the vehicle.
5. Power ON the transmitter and then the vehicle. Wait 5 seconds for the ESC to initialize. Always power the transmitter ON before the vehicle and power it OFF after the vehicle has been powered OFF.
6. Check the steering and throttle control directions. Verify that the servos are moving in the correct direction.
7. Drive your vehicle.
8. When finished, always turn off the ESC and unplug the battery.
9. Perform any necessary maintenance.

## CHARGING THE BATTERY //

Choose a battery designed to work with the Dynamite® 60A Brushed Waterproof ESC (DYNS2210). We recommend the Dynamite® Reaction® 7.4V 4000mAh 2S 50C LiPo: Hardcase with EC3™ connector (DYNB3800EC). Choose a charger designed to charge 2S Li-Po batteries.

We recommend the Dynamite® Prophet™ Sport Li-Po 35W AC Battery Charger (DYNC2005CA). Refer to your battery and charger manuals for usage, safety, and charging information.

# INSTALLING THE BATTERY

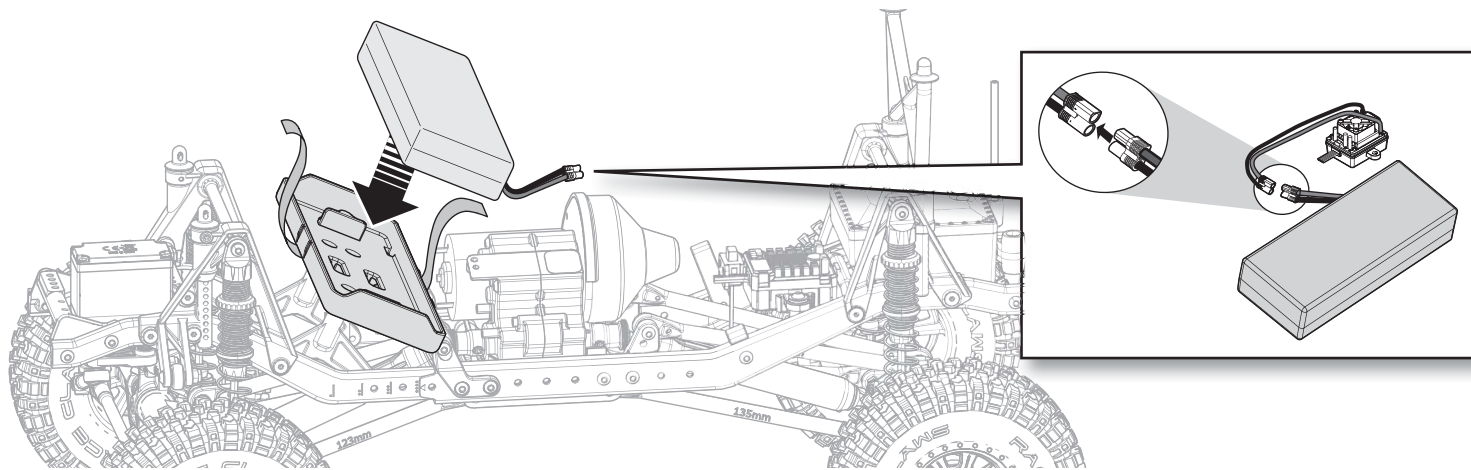

1. Ensure the ESC is powered OFF.
2. Loosen the hook and loop battery strap found on the battery tray and install the fully charged battery in to the vehicle.
3. Secure the battery to the battery tray using the hook and look battery strap.
4. Connect the battery to the ESC.
5. Power on the Transmitter and wait 5 seconds.
6. Power on the ESC.

# TRANSMITTER CONTROLS

## Reverse Switch



Allows you to change the direction of steering (ST. REV) and throttle (TH. REV) controls (Ensure proper function with a radio system test)

## Throttle Dual Rate



Adjusts the maximum amount of throttle the model can be given

## Steering Rate



Adjusts the amount the front wheels move when the steering wheel is turned left or right

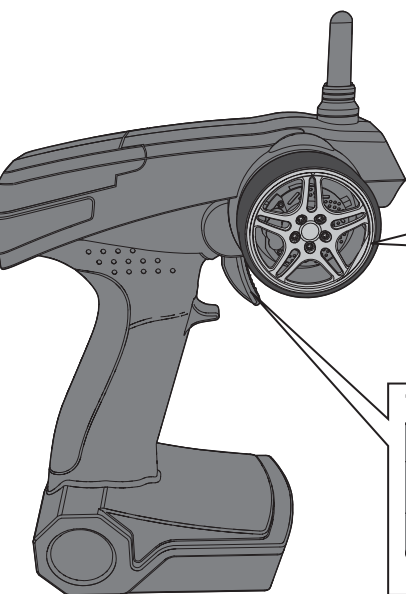

## Steering Wheel



Controls RIGHT and LEFT steering

## Throttle Trigger

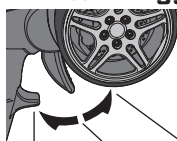

Controls power to the motor for forward or reverse

Forward Stop Reverse

## Battery Level Indicator

- Solid Red: Battery voltage is good (above 4V)
- Flashing Red: Battery voltage is critically low (below 4V). Replace transmitter batteries

## Throttle Trim



Adjusts the neutral point of the electronic speed control

## Steering Trim



Adjust to make the model drive straight with no input at the steering wheel

## Power Switch

Power ON or OFF the transmitter



# INSTALLING TRANSMITTER BATTERIES

This transmitter requires 4 AA batteries.

1. Remove the battery cover from the transmitter.
2. Install the batteries as shown.
3. Install the battery cover.

**CAUTION:** If using rechargeable batteries, charge only rechargeable batteries. Charging non-rechargeable batteries may cause the batteries to burst, resulting in injury to persons and/or damage to property.

**CAUTION:** Risk of explosion if battery is replaced by an incorrect type. Dispose of used batteries according to national regulations.

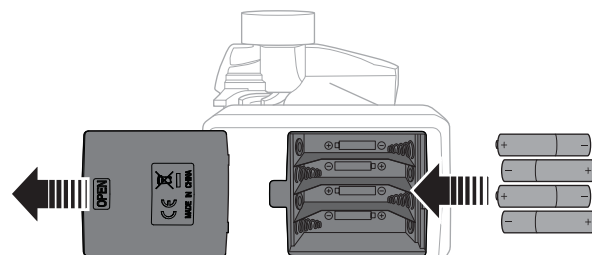

## BINDING YOUR TRANSMITTER AND RECEIVER

Binding is the process of programming the receiver to recognize the GUID (Globally Unique Identifier) code of a single specific transmitter. When a receiver is bound to a transmitter, the receiver will only respond to that specific transmitter. Follow the binding instructions for your transmitter.

**The included transmitter and receiver are bound at the factory.** If you need to rebind, follow the instructions below.

1. Power OFF the receiver and transmitter.
2. Connect a fully charged battery to the ESC.
3. Insert the bind plug into the receiver's binding pins and power ON the ESC. The receiver LED flashes.
4. Power ON the transmitter.
5. The receiver LED turns solid when binding is successful.

### YOU MUST REBIND WHEN:

- Different failsafe positions are desired e.g., when throttle or steering reversing has been changed.
- Binding the receiver to a different transmitter.

**NOTICE:** Do not attempt to bind the transmitter and receiver if there are other compatible transmitters in bind mode within 400 feet. Doing so may result in unexpected binding.

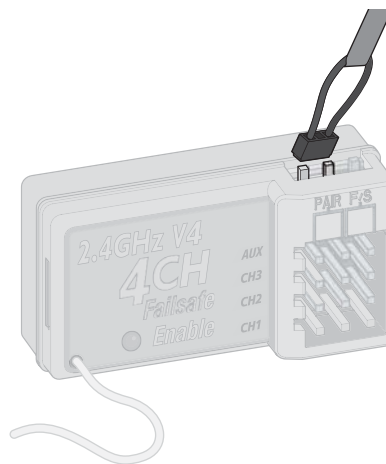

ECX13009 RECEIVER

### FAILSAFE

Failsafe positions are also set during binding. In the unlikely event that the radio link is lost during use, the receiver will drive the servos to their preprogrammed failsafe positions (normally throttle stop and straight steering). If the receiver is turned on prior to turning on the transmitter, the receiver will enter failsafe mode. When the transmitter is turned on, normal control is resumed.

## DRIVING PRECAUTIONS

- » Maintain sight of the vehicle at all times.
- » Routinely inspect the vehicle for loose wheel hardware.
- » Routinely inspect the steering assembly for any loose hardware. Driving the vehicle off-road can cause fasteners to loosen over time.
- » Do not drive the vehicle in tall grass. Doing so can damage the vehicle or electronics.
- » Stop driving the vehicle when you notice a lack of power. Driving the vehicle when the battery is discharged can cause the receiver to power off. If the receiver loses power, you will lose control of the vehicle. Damage due to an over-discharged Li-Po battery is not covered under warranty.

**CAUTION:** Do not discharge a Li-Po battery below 3V per cell. Batteries discharged to a voltage lower than the lowest approved voltage may become damaged, resulting in loss of performance and potential fire when batteries are charged.

- » Do not apply forward or reverse throttle if the vehicle is stuck. Applying throttle in this instance can damage the motor or ESC.
- » After driving the vehicle, allow the electronics to cool before driving the vehicle again.

**IMPORTANT:** Keep wires away from all moving parts.

## RUN TIME

The largest factor in run time is the capacity of the battery pack. A larger mAh rating increases the amount of run time experienced.

The condition of a battery pack is also an important factor in both run time and speed. The battery connectors may become hot during driving. Batteries will lose performance and capacity over time.

Driving the vehicle from a stop to full speed repeatedly will damage the batteries and electronics over time. Sudden acceleration will also lead to shorter run times.

### TO IMPROVE RUN TIMES

- » Keep your vehicle clean and well maintained.
- » Allow more airflow to the ESC and motor.
- » Change the gearing to a lower ratio. A lower ratio decreases the operating temperature of the electronics. Use a smaller pinion gear or larger spur gear to lower the gear ratio.
- » Use a battery pack with a higher mAh rating.
- » Use the optimum charger to charge battery packs (Visit your local hobby dealer for more information)

## POWERING ON THE VEHICLE

1. Center the ST TRIM and TH TRIM dials on the transmitter.
2. Power on the transmitter.
3. Remove the body from the vehicle.
4. Connect a fully charged battery pack to the ESC.
5. Power on the ESC.
6. Re-install the body on the vehicle.

## BEFORE RUNNING YOUR VEHICLE

1. Check for free suspension movement. All suspension arms and steering components should move freely. Any binds will cause the vehicle to handle poorly.
2. Charge a battery pack. Always charge the battery pack as per the battery and/or charger manufacturers' instructions.
3. Set the transmitter steering trim. Follow the instructions to set the steering trim/subtrim so that the vehicle drives straight with no input to the steering.
4. Perform a Control Direction Test.

## PERFORMING A CONTROL DIRECTION TEST

Perform a control test with the vehicle wheels off the ground. If the wheels rotate after the vehicle is powered ON, adjust the TH Trim knob until they stop. To make the wheels move forward, pull the trigger. To reverse them, wait for the wheels to stop, then push the trigger. When moving forward, the wheels should maintain a straight line without any steering wheel input. If not, adjust the ST Trim knob, so the wheels maintain a straight line without having to turn the steering wheel.

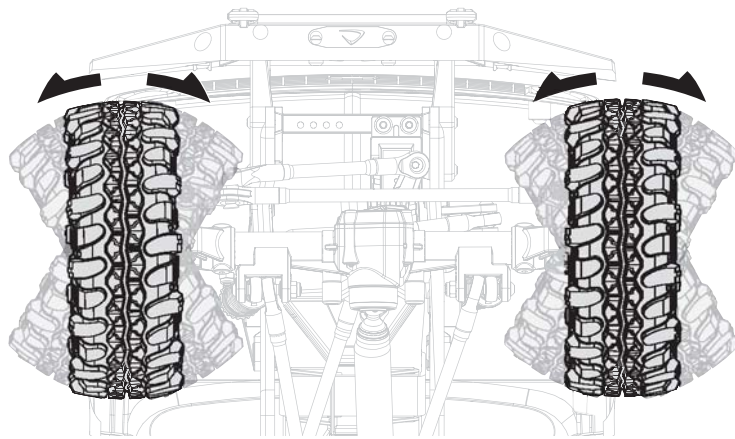

## DYNAMITE® 60A BRUSHED WATERPROOF ESC (DYNS2210) //////////////////////////////////////

### SPECIFICATIONS

Type	Brushed
Constant/Peak	60A/360A
Resistance	0.0008 Ohms
Function	Forward/Brake/Reverse, Forward/Brake, Forward/Reverse (Crawler Mode)
Operation	Proportional forward, proportional reverse with braking delay, Crawler Mode
Battery Type/Input Voltage	2 cell Li-Po/Li-Fe; 6-7 cell Ni-MH/Ni-Cd
Motor Type	540-/550-size closed endbell motors: 2S Li-Po down to 8T
BEC Output	5V/2A
Overload Protection	Thermal
Dimensions	35.6mm x 34mm x 18mm (1.40 in x 1.34 in x 0.71 in)
Weight	40 g (1.41 oz) with wires
Battery Connector	EC3™ connector
Motor Connector	3.5mm Tamiya-style bullet

### CONNECTING THE ESC

1. Connect the RED (+) ESC wire to the RED (+) motor wire.
2. Connect the BLACK (-) ESC wire to the BLACK (-) motor wire.

**NOTICE:** Always disconnect the battery from the ESC when you have finished operating your vehicle. The ESC's switch only controls power to the receiver and servos. The ESC will continue to draw current when connected to the battery, resulting in possible damage to the battery through over discharge.

### PROGRAMMING

The ESC comes with two jumpers pre-installed in the MODE: F/B (forward/brake) and BATT: Li-Po configurations.

To change the mode to F/B/R (forward/brake/reverse) or F/R (forward/reverse) or change the battery type to Ni-MH

1. Power OFF the ESC.
2. Disconnect the jumper from the default port and connect it to the desired port.
3. Power ON the ESC.

If the jumpers are lost or not installed, the ESC will default to MODE: F/B/R and BATT: Li-Po.

**WARNING:** Do not connect bind plugs or receiver servo leads into the ESC programming port. Doing so may damage the ESC and/or components.

### ESC LED STATUS

- » No ESC LEDs will glow when there is no throttle input from the transmitter.
- » The red ESC LED glows when there is any throttle input from the transmitter.

### AUDIBLE WARNING TONES

- 1. Input Voltage:** The ESC checks the input voltage when it is powered ON. If a voltage problem is detected, the ESC continuously sounds 2 beeps with a 1 second pause (xx-xx-xx). Power OFF the ESC and ensure the connections are secure and that the battery power is not too low for safe operation.
- 2. Radio Connection:** The ESC checks radio signal input when it is powered ON. If a problem is detected, the ESC continuously sounds 1 beep with a 2 second pause (x--x--x). Power OFF the ESC and ensure the radio system is operating correctly.

### ESC CALIBRATION PROCEDURE

Ensure proper ESC function by calibrating the ESC to your transmitter inputs.

1. Power OFF the ESC.
2. Ensure your transmitter is powered ON, the throttle is not reversed, the throttle trim is neutral and the throttle travel range is at 100%. Disable any special functions such as ABS, etc.
3. Keep the throttle at neutral and power ON the ESC.
4. The ESC automatically calibrates the throttle range after 3 seconds.
5. One long beep will sound when the ESC is ready to run.

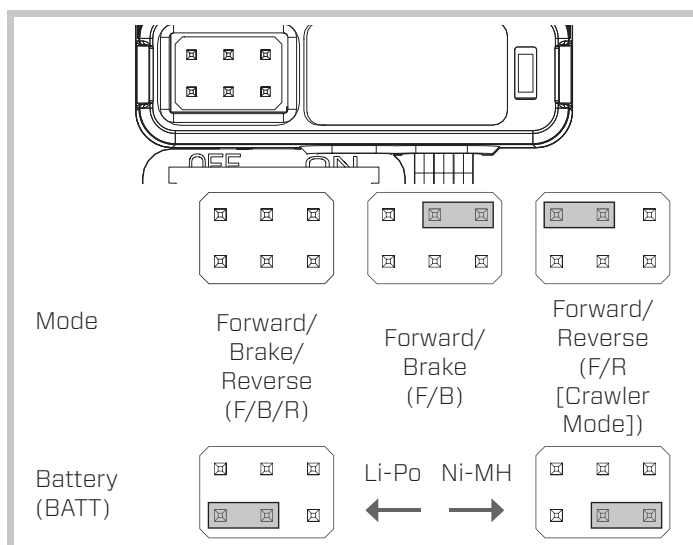



## LIMITED WARRANTY //////////////////////////////////////

### What this Warranty Covers

Horizon Hobby, LLC, (Horizon) warrants to the original purchaser that the product purchased (the "Product") will be free from defects in materials and workmanship at the date of purchase.

### What is Not Covered

This warranty is not transferable and does not cover (i) cosmetic damage, (ii) damage due to acts of God, accident, misuse, abuse, negligence, commercial use, or due to improper use, installation, operation or maintenance, (iii) modification of or to any part of the Product, (iv) attempted service by anyone other than a Horizon Hobby authorized service center, (v) Product not purchased from an authorized Horizon dealer, or (vi) Product not compliant with applicable technical regulations or (vii) use that violates any applicable laws, rules, or regulations.

OTHER THAN THE EXPRESS WARRANTY ABOVE, HORIZON MAKES NO OTHER WARRANTY OR REPRESENTATION, AND HEREBY DISCLAIMS ANY AND ALL IMPLIED WARRANTIES, INCLUDING, WITHOUT LIMITATION, THE IMPLIED WARRANTIES OF NON-INFRINGEMENT, MERCHANTABILITY AND FITNESS FOR A PARTICULAR PURPOSE. THE PURCHASER ACKNOWLEDGES THAT THEY ALONE HAVE DETERMINED THAT THE PRODUCT WILL SUITABLY MEET THE REQUIREMENTS OF THE PURCHASER'S INTENDED USE.

### Purchaser's Remedy

Horizon's sole obligation and purchaser's sole and exclusive remedy shall be that Horizon will, at its option, either (i) service, or (ii) replace, any Product determined by Horizon to be defective. Horizon reserves the right to inspect any and all Product(s) involved in a warranty claim. Service or replacement decisions are at the sole discretion of Horizon. Proof of purchase is required for all warranty claims. SERVICE OR REPLACEMENT AS PROVIDED UNDER THIS WARRANTY IS THE PURCHASER'S SOLE AND EXCLUSIVE REMEDY.

### Limitation of Liability

HORIZON SHALL NOT BE LIABLE FOR SPECIAL, INDIRECT, INCIDENTAL OR CONSEQUENTIAL DAMAGES, LOSS OF PROFITS OR PRODUCTION OR COMMERCIAL LOSS IN ANY WAY, REGARDLESS OF WHETHER SUCH CLAIM IS BASED IN CONTRACT, WARRANTY, TORT, NEGLIGENCE, STRICT LIABILITY OR ANY OTHER THEORY OF LIABILITY, EVEN IF HORIZON HAS BEEN ADVISED OF THE POSSIBILITY OF SUCH DAMAGES. Further, in no event shall the liability of Horizon exceed the individual price of the Product on which liability is asserted. As Horizon has no control over use, setup, final assembly, modification or misuse, no liability shall be assumed nor accepted for any resulting damage or injury. By the act of use, setup or assembly, the user accepts all resulting liability. If you as the purchaser or user are not prepared to accept the liability associated with the use of the Product, purchaser is advised to return the Product immediately in new and unused condition to the place of purchase.

### Law

These terms are governed by Illinois law (without regard to conflict of law principals). This warranty gives you specific legal rights, and you may also have other rights which vary from state to state. Horizon reserves the right to change or modify this warranty at any time without notice.

### WARRANTY SERVICES

#### Questions, Assistance, and Services

Your local hobby store and/or place of purchase cannot provide warranty support or service. Once assembly, setup or use of the Product has been started, you must contact your local distributor or Horizon directly. This will enable Horizon to better answer your questions and service you in the event

that you may need any assistance. For questions or assistance, please visit our website at [www.horizonhobby.com](http://www.horizonhobby.com), submit a Product Support Inquiry, or call the toll free telephone number referenced in the Warranty and Service Contact Information section to speak with a Product Support representative.

### Inspection or Services

If this Product needs to be inspected or serviced and is compliant in the country you live and use the Product in, please use the Horizon Online Service Request submission process found on our website or call Horizon to obtain a Return Merchandise Authorization (RMA) number. Pack the Product securely using a shipping carton. Please note that original boxes may be included, but are not designed to withstand the rigors of shipping without additional protection. Ship via a carrier that provides tracking and insurance for lost or damaged parcels, as Horizon is not responsible for merchandise until it arrives and is accepted at our facility. An Online Service Request is available at [http://www.horizonhobby.com/content/service-center\\_render-service-center](http://www.horizonhobby.com/content/service-center_render-service-center). If you do not have internet access, please contact Horizon Product Support to obtain a RMA number along with instructions for submitting your product for service. When calling Horizon, you will be asked to provide your complete name, street address, email address and phone number where you can be reached during business hours. When sending product into Horizon, please include your RMA number, a list of the included items, and a brief summary of the problem. A copy of your original sales receipt must be included for warranty consideration. Be sure your name, address, and RMA number are clearly written on the outside of the shipping carton.

**NOTICE:** Do not ship Li-Po batteries to Horizon. If you have any issue with a Li-Po battery, please contact the appropriate Horizon Product Support office.

### Warranty Requirements

For Warranty consideration, you must include your original sales receipt verifying the proof-of-purchase date. Provided warranty conditions have been met, your Product will be serviced or replaced free of charge. Service or replacement decisions are at the sole discretion of Horizon.

### Non-Warranty Service

Should your service not be covered by warranty, service will be completed and payment will be required without notification or estimate of the expense unless the expense exceeds 50% of the retail purchase cost. By submitting the item for service you are agreeing to payment of the service without notification. Service estimates are available upon request. You must include this request with your item submitted for service. Non-warranty service estimates will be billed a minimum of 1/2 hour of labor. In addition you will be billed for return freight. Horizon accepts money orders and cashier's checks, as well as Visa, MasterCard, American Express, and Discover cards. By submitting any item to Horizon for service, you are agreeing to Horizon's Terms and Conditions found on our website [http://www.horizonhobby.com/content/service-center\\_render-service-center](http://www.horizonhobby.com/content/service-center_render-service-center).

**ATTENTION:** Horizon service is limited to Product compliant in the country of use and ownership. If received, a non-compliant Product will not be serviced. Further, the sender will be responsible for arranging return shipment of the un-serviced Product, through a carrier of the sender's choice and at the sender's expense. Horizon will hold non-compliant Product for a period of 60 days from notification, after which it will be discarded.



# WARRANTY AND SERVICE CONTACT INFORMATION //////////////////////////////////////

Country of Purchase	Horizon Hobby	Contact Information	Address
United States of America	Horizon Service Center (Repairs and Repair Requests)	servicecenter.horizonhobby.com/RequestForm/	1608 Interstate Dr. Champaign, Illinois 61822 USA
	Horizon Product Support (Product Technical Assistance)	productsupport@horizonhobby.com 877-504-0233	
	Sales	websales@horizonhobby.com 800-338-4639	
European Union	Horizon Technischer Service	service@horizonhobby.eu	Hanskampring 9 D 22885 Barsbüttel, Germany
	Sales: Horizon Hobby GmbH	+49 (0) 4121 2655 100	

## FCC Statement

**FCC ID: XNZEEX13008**

This equipment has been tested and found to comply with the limits for Part 15 of the FCC rules. These limits are designed to provide reasonable protection against harmful interference in a residential installation. This equipment generates uses and can radiate radio frequency energy and, if not installed and used in accordance with the instructions, may cause harmful interference to radio communications. However, there is no guarantee that interference will not occur in a particular installation. If this equipment does cause harmful interference to radio or television reception, which can be determined by turning the equipment off and on, the user is encouraged to try to correct the interference by one or more of the following measures:

- Reorient or relocate the receiving antenna.
- Increase the separation between the equipment and receiver.
- Connect the equipment to an outlet on a circuit different from that to which the receiver is connected.

This device complies with part 15 of the FCC rules. Operation is subject to the following two conditions: (1) This device may not cause harmful interference, and (2) this device must accept any interference received, including interference that may cause undesired operation.

**NOTICE:** Modifications to this product will void the user's authority to operate this equipment.

## IC Information

**IC: 20264-ECX13008**

This device complies with Industry Canada licence-exempt RSS standard(s). Operation is subject to the following two conditions: (1) this device may not cause interference, and (2) this device must accept any

interference, including interference that may cause undesired operation of the device.”

**CE EU Compliance Statement:** Horizon Hobby, LLC hereby declares that this product is in compliance with the essential requirements and other relevant provisions of the RED and EMC Directives.

A copy of the EU Declaration of Conformity is available online at: <http://www.horizonhobby.com/content/support-render-compliance>.



### Instructions for disposal of WEEE by users in the European Union

This product must not be disposed of with other waste. Instead, it is the user's responsibility to dispose of their waste equipment by handing it over to a designated collections point for the recycling of waste electrical and electronic equipment. The separate collection and recycling of your waste equipment at the time of disposal will help to conserve natural resources and ensure that it is recycled in a manner that protects human health and the environment. For more information about where you can drop off your waste equipment for recycling, please contact your local city office, your household waste disposal service or where you purchased the product.

# REPLACEMENT PARTS LIST • ERSATZTEILE • LISTE DES PIÈCES DE RECHANGE • ELENCO DEI RICAMBI

Part #	English	Deutsch	Français	Italiano
LOS4114	48 Pitch Pinion Gear, 14T	48 Pitch Ritzel, 14T	Pignon moteur 48DP, 14T	48 Pitch pignone, 14T
DYNS2210	Waterproof 60A Forward/Reverse Brushed ESC	Wasserdicht 60A Vorwärts / Rückwärts gebürstet ESC	Étanche à l'eau 60A avant / inversé ESC brossé	Impermeabile 60A ESC spazzolato in avanti / invertito
SPMS605	9KG Servo, Waterproof, Metal Gear, 23T	9KG Servo, wasserdicht, Metallgetriebe, 23T	9KG Servo, imperméable à l'eau, équipement métallique, 23T	Servo 9KG, impermeabile, ingranaggio del metallo, 23T
TLR5903	Button Head Screws, M3 x 10mm (10)	Halbrundschrauben, M3x10mm (10)	Vis à tête bombée, M3x10mm (10)	Viti a testa tonda, M3 x 10mm (10)
VTR232013	Drive Shaft Yoke, Cup & Hardware (1): Twin Hammers	Antriebswellenmitnehmer und Zubehör (1): Twin Hammers	Twin Hammers - Coupelle de cardan avec croisillon et visserie (1)	Giogo albero trasm., coppa e viteria (1): Twin Hammers
TLR6105	E-Clip, 3mm (12)	E-Clip, 3mm (12)	E-clips 3mm (12)	E-Clip, 3mm (12)
VTR232072	Input Drive Shaft Yoke, Cup & Hdw (1)	Antriebswellengabel, Außenring, Distanzscheibe & Hdw (1)	Tête de cardan, coupelle et accessoires	Giogo albero ingresso, coppa e viteria
LOS235014	Lock Nut, M2 x 0.4 x 4mm (10)	Sicherungsmutter, M2 x 0,4 x 4 mm (10)	Contre-écrou M2 x 0,4 x 4 mm (10)	Dado, M2 x 0,4 x 4 mm (10)
VTR233030	Lower Shock Spring Set; Soft, Med, Hard (2ea)	Unterer Stoßdämpfer-Federnsatz; Weich, Mittel, Hart (jeweils 2)	Ressorts d'amortisseurs inférieurs; doux, moyens, durs (2ea)	Set molle ammortizzatori inferiori; morbidi, medi, duri (2ea)
VTR235222	M2.8 x 10mm CHSS, Self Tapping (10)	M2,8 x 10 mm, Inbusschraube, selbstschneidend (10)	M2.8 x 10 mm CHSS, autotaraudeuses (10)	Autofilettante M2.8 x 10 mm CHSS (10)
VTR235223	M2.8 x 14mm CHSS, Self Tapping (10)	M2,8 x 14 mm, Inbusschraube, selbstschneidend (10)	M2.8 x 14 mm CHSS, autotaraudeuses (10)	Autofilettante M2.8 x 14 mm CHSS (10)
VTR235328	M3 x 20mm, Cup Point Set Screw (10)	M3 x 20 mm, Stellschraube mit Ringschneide (10)	M3 x 20 mm, Vis de fixation à bout cuvette (10)	Viti bombata M3 x 20 mm (10)
VTR235328	M3 x 20mm, Cup Point Set Screw (10)	M3 x 20 mm, Stellschraube mit Ringschneide (10)	M3 x 20 mm, Vis de fixation à bout cuvette (10)	Vite bombata M3 x 20 mm (10)
VTR235035	M3 x 30mm, Cap Head Screw (10)	M3 x 30 mm, Inbusschraube (10)	Vis d'assemblage creuses M3 x 30 mm (10)	Vite a testa tonda M3 x 30 mm (10)
VTR235330	M3 x 30mm, Cup Point Set Screw (10)	M3 x 30 mm, Stellschraube mit Ringschneide (10)	M3 x 30 mm, Vis de fixation à bout cuvette (10)	Vite bombata M3 x 30 mm (10)
VTR232067	Motor Plate, Gear Cover & Hardware	Motorplatte, Getriebeabdeckung und Zubehör	Plaque moteur, cache d'engrenage et matériel	Piastra motore, carter ingranaggi e viteria
VTR243008	O-Ring, Shocks (8) GLU, GLF, Hal, Rap, Ra	O-Ring, Stoßdämpfer (8) GLU, GLF, Hal, Rap, Ra	Amortisseurs à joint torique (8) GLU, GLF, Hal, Rap, Ra	O-Ring, ammortizzatori (8) GLU, GLF, Hal, Rap, Ra
VTR243010	O-Rng, Bleeder Screw (4): GLU, GLF, Hal, Rap	O-Ring, Luftablassschraube (4): GLU, GLF, Hal, Rap	Joint torique, vis de purge (4) : GLU, GLF, Hal, Rap	O-Rng, vite di sfiato (4): GLU, GLF, Hal, Rap
VTR246001	Screw Pin, Clip Post (10): GLU/LOS	Schraubenstift, Klemmenstab (10): GLU/LOS	Vis à broche, attache (10) : GLU/LOS	Vite a perno, piolo a clip (10): GLU/LOS
VTR233027	Shock Body, Adjustable Collar, Upper & Lower Cap (4)	Stoßdämpfergehäuse, verstellbare Hülse, obere und untere Kappe (4)	Carrosserie d'amortisseur, bague ajustable, couvercle supérieur et inférieur (4)	Corpo ammortizzatore, collare regolabile, tappo superiore e inferiore (4)
VTR233028	Shock End, Cap, Rubber Stop & Mid Collar (4)	Stoßdämpferendstück, Kappe, Gummianschlag und mittlere Hülse (4)	Extrémité, capuchon d'amortisseur, bouchon en caoutchouc et bague centrale (4)	Estremità ammortizzatore, tappo, arresto in gomma e collare intermedio (4)
VTR232069	Spur Gear, 86T, 48P (2)	Stirnrad, 86T, 48P (2)	Engrenage cylindrique, 86T, 48P (2)	Corona 86T, 48P (2)
VTR233029	Upper Shock Spring Set; Soft, Med, Hard (2ea)	Oberer Stoßdämpfer-Federnsatz; Weich, Mittel, Hart (jeweils 2)	Ressorts d'amortisseurs supérieurs; doux, moyens, durs (2ea)	Set molle ammortizzatori superiori; morbidi, medi, duri (2ea)
LOSA6957	10 x 15 x 4mm Ball Bearing (2) w/ Nylon Retainer	10 x 15 x 4 mm, Kugellager (2) mit Nylon-Halter	Roulements à billes 10 x 15 x 4 mm (2) avec bague de retenue en nylon	Cuscinetto a sfera 10 x 15 x 4 mm (2) con fermo in nylon
VTR237003	4 x 8 x 3mm Ball Bearing (2)	4 x 8 x 3mm, Kugellager (2)	Roulement à billes 4 x 8 x 3 mm (2)	Cuscinetto a sfera 4 x 8 x 3 mm (2)
VTR237004	5 x 10 x 4mm Ball Bearing (2)	5 x 10 x 4mm, Kugellager (2)	Roulement à billes 5 x 10 x 4 mm (2)	Cuscinetto a sfera 5 x 10 x 4 mm (2)
VTR237009	5 x 13 x 4mm Ball Bearing (2)	5 x 13 x 4mm, Kugellager (2)	Roulement à billes 5 x 13 x 4 mm (2)	Cuscinetto a sfera 5 x 13 x 4 mm (2)
VTR237014	6 x 12 x 4mm Ball Bearing (2)	6 x 12 x 4mm, Kugellager (2)	Roulement à billes 6 x 12 x 4 mm (2)	Cuscinetto a sfera 6 x 12 x 4 mm (2)
LOSA6945	8 x 14 x 4mm Rubber Sealed Ball Bearing (4)	8 x 14 x 4 mm, gummiversiegelt Kugellager (4)	Roulement à billes hermétique en caoutchouc 8 x 14 x 4 mm (4)	Cuscinetti a sfera sigillati in gomma 8 x 14 x 4 mm (4)
VTR232078	Axle Shafts Rear (2)	Achswelle, Heck (2)	Arbres d'essieux arrière (2)	Albero assale posteriore (2)
VTR232074	Axle Housing & Link Mount Set FR/RR	Befestigungssatz für Achsgehäuse und Gestänge Front/Heck	Ensemble de support et carter d'essieu avant/arrière	Alloggiamento assale e supporto braccetto FR/RR
VTR231036	Bumper Set FR/RR	Stoßstangensatz Front/Heck	Jeu de pare-chocs avant/arrière	Ammortizzatore FR/RR
LOS235025	Button Head Screws M3 x 30mm (10)	Rundkopfschraube, M3 x 30 mm (10)	Vis à tête bombée, M3 x 30 mm (10)	Viti a testa tonda, M3 x 30 mm (10)
VTR231034	Chassis Brace Set	Karosseriestrebensatz	Ensemble de support de carrosserie	Bretella telaio
VTR231033	Chassis Frame Rail Set	Karosserie-Rahmenschienensatz	Ensemble de rails de cadre du châssis	Binario telaio
VTR232075	Differential Cover & Differential Skid-Plate Set FR/RR	Satz mit Differenzialgehäuse und Differenzial-Gleitbrett, Front/Heck	Ensemble de couvercle et plaque de protection de différentiel avant/arrière	Carter differenziale e piastra proteggi differenziale FR/RR
DYNS1216	Dynamite 35-Turn 540 Brushed Motor	Dynamite-540-Bürstenmotor mit 35 Turns	Moteur à balais Dynamite 35-Turn 540	Motore a spazzole 35T Dynamite 540
VTR232076	Front CV Shaft Set	Gleichlaufwellensatz, Front	Ensemble d'arbre CV avant	Albero CV anteriore
VTR232079	HD Molded Driveshaft Set	Gegossener Antriebswellensatz, HD	Ensemble moulé d'arbre de transmission ultra-résistant	Albero di trasmissione stampato HD
VTR232080	HD Pinion Drive Gear 13T (2)	Antriebszahnrad, HD, 13T (2)	Engrenage à pignons d'entraînement ultra-résistant 13T (2)	Trasmissione pignone HD 13T (2)
VTR232077	Hex Pins & Lock Nut (4)	Sechskantstifte und Sicherungsmuttern (4)	Tiges hexagonales et contre-écrous (4)	Perni esagonali e dado (4)
VTR230058	LED Light St w/ Amber Running Light	LED-Licht-Satz mit gelber Betriebsleuchte	Ensemble d'éclairage DEL avec feux de position orange	LED St con spia color ambra
VTR235008	M2 x 16mm Cap Head Screw (10)	M2 x 16 mm, Inbusschraube (10)	Vis d'assemblage creuses M2 x 16 mm (10)	Viti a testa tonda M2 x 16 mm (10)
VTR235009	M2 x 20mm Cap Head Screw (10)	M2 x 20mm, Inbusschraube (10)	Vis d'assemblage creuses M2 x 20 mm (10)	Vite a testa tonda M2 x 20 mm (10)
ECX1059	M3 Locknut (4)	M3-Sicherungsmutter (4)	Contre-écrou M3 (4)	Dado M3 (4)
VTR235108	M3 x 12mm Button Head Screw (10)	M3 x 12 mm, Rundkopfschraube (10)	Vis à tête bombée M3 x 12 mm (10)	Vite a testa tonda M3 x 12 mm (10)

# REPLACEMENT PARTS LIST • ERSATZTEILE • LISTE DES PIÈCES DE RECHANGE • ELENCO DEI RICAMBI

Part #	English	Deutsch	Français	Italiano
VTR235322	M3 x 5mm Cup Point Setscrew (10)	M3 x 5 mm, Stellschraube mit Ringschneide (10)	Vis de fixation à bout cuvette M3 x 5 mm (10)	Vite bombata M3 x 5 mm (10)
VTR235105	M3 x 6mm Button Head Screw (10)	M3 x 6 mm, Rundkopfschraube (10)	Vis à tête bombée M3 x 6 mm (10)	Vite a testa tonda M3 x 6mm (10)
VTR235174	M3 x 6mm Flat Head Screw (10)	M3 x 6 mm, Flachkopfschraube (10)	Vis à tête plate M3 x 6 mm (10)	Vite a testa piatta M3 x 6 mm (10)
VTR235025	M3 x 8mm Cap Head Screw (10)	M3 x 8 mm, Inbusschraube (10)	Vis d'assemblage creuse M3 x 8 mm (10)	Viti a testa tonda M3 x 8 mm (10)
VTR236046	M4 Nylock Flanged Serrated Nut(10)	Gezahnnte M4-Nylock-Flanschmutter (10)	Contre-écrou Nylock à embase striée et bridée (10)	Dado serrato flangiato Nylock M4 (10)
VTR232070	Molded Center Driveshaft Set	Gegossener mittlerer Antriebswellensatz	Ensemble moulé d'arbre de transmission central	Albero di trasmissione centrale stampato
VTR331016	Solid Mount Battery Tray Conversion	Akkualterung-Umbausatz für Festverbauung	Conversion de support de batterie à montage solide	Conversione supporto batteria pieno
VTR234031	Suspension Link & Pivot Set; Plastic	Aufhängungssatz mit Gestänge und Drehgelenken, Kunststoff	Ensemble de pivot et bras de suspension en plastique	Braccetto di sospensione e kit perni; plastica
VTR231037	Receiver Box & ESC Tray	Empfängerkasten und Halterung für Geschwindigkeitsregler	Compartiment de récepteur et support de variateur ESC	Scatola ricevitore e supporto ESC
VTR233026	Shock Shaft & Piston Set (4)	Satz mit Stoßdämpferstange und Kolben (4)	Ensemble de pistons et bras d'amortisseurs (4)	Albero ammortizzatore e set pistone (4)
VTR231035	Shock Tower Set FR/RR	Stoßdämpferbrückensatz, Front/Heck	Ensemble de tour d'amortisseur avant/arrière	Torre ammortizzatore FR/RR
VTR232023	Slipper Back Plate: Twin Hammers	Gleiter-Rückplatte: Twin Hammers	Plaque arrière de sabot : Twin Hammers	Piastra posteriore scorrevole Twin Hammers
VTR232024	Slipper Pads (2): Twin Hammers	Gleitkissen (2): Twin Hammers	Sabots de piston (2) : Twin Hammers	Pattino scorrevole (2): Twin Hammers
VTR232026	Slipper Spring Cup Spacer/Washer	Gleitfeder, Teller, Abstandshalter/Scheibe	Rondelle/entretoise de coupelle de ressort de sabot	Distanziatore/Rondella coppa molla scorrevole
VTR232073	Spool 24T & Pinion Gear 13T	Spulenzahnrad, 24T und Antriebszahnrad, 13T	Bobine 24T et engrenage à pignons 13T	Bobina 24T e ingranaggi pignone 13T
VTR234026	Steering Linkage Set	Lenkstangensatz	Ensemble de tringlerie de direction	Leveraggi di sterzo
VTR234025	Steering Spindle & Hub Set FR/RR	Lenkspindel- und Nabensatz, Front/Heck	Ensemble d'arbre de direction et moyeu avant/arrière	Mandrino di sterzo e mozzo FR/RR
VTR232001	Transmission Case: Twin Hammers	Getriebeabdeckung: Twin Hammers	Boîtier de transmission : Twin Hammers	Scatola del cambio: Twin Hammers
VTR232017	Transmission Shaft Set	Getriebewellensatz	Ensemble d'arbre de transmission	Set albero trasmissione
ECX13008	2.4 GHz 2-Channel Transmitter	2,4-GHz-Sender mit 2 Kanälen	Émetteur à 2 canaux 2,4 GHz	Trasmittente a 2 canali 2,4 GHz
ECX13009	2-Channel Waterproof Surface Receiver	Wasserdichter Bodenempfänger mit 2 Kanälen	Récepteur de surface étanche à 2 canaux	Ricevitore impermeabile a 2 canali

# OPTIONAL PARTS LIST • OPTIONALE BAUTEILE • PIÈCES OPTIONNELLES • PEZZI OPZIONALI // // // // //

Part #	English	Deutsch	Français	Italiano
VTR331014	V2 Steering Servo Horn, 23T, Alum, ASN	V2-Lenkungs-Servohorn, 23T, Aluminium, ASN	Renvoi de commande du servo de direction V2, 23T, Alum, ASN	Squadretta di servo di sterzo V2 23T, Alum, ASN
VTR331015	V2 Steering Servo Horn, 25T, Alum, ASN	V2-Lenkungs-Servohorn, 25T, Aluminium, ASN	Renvoi de commande du servo de direction V2, 25T, Alum, ASN	Squadretta di servo di sterzo V2 25T, Alum, ASN
VTR234028	3mm Threaded Aluminum Link, 61mm (4)	61-mm-Aluminiumstangen mit 3-mm-Gewinde (4)	Bras fileté en aluminium 3 mm, 61 mm (4)	Leveraggio alluminio filettato 3 mm, 61 mm (4)
VTR234029	3mm Threaded Aluminum Link, 66mm (4)	66-mm-Aluminiumstangen mit 3-mm-Gewinde (4)	Ensemble fileté en aluminium 3 mm, 66 mm (4)	Leveraggio alluminio filettato 3 mm, 66mm (4)
VTR230057	68 Ford F-100 P/U Cab Set, Clear	Kabinensatz, 68er Ford F-100-Pickup, durchsichtig	Ensemble de cabine 68 Ford F-100 P/U, transparent	Set cab 68 Ford F-100 P/U trasparente
VTR334017	Adjustable Coil over Shocks, Aluminum (2)	Verstellbare federunterstützte Stoßdämpfer, Aluminium (2)	Amortisseurs à boudins ajustables, aluminium (2)	Bobina regolabile su ammortizzatori, alluminio (2)
VTR331008	Battery Tray Mounts, Aluminum	Befestigungsteile für Akkualterung, Aluminium	Supports de batterie, aluminium	Supporti batteria, alluminio
VTR231038	Battery Tray, Mounts & Strap	Akkualterung, Befestigungsteile und Band	Supports et boucles de batterie	Supporti e fascette batteria
VTR246005	Flange Pivot Ball, 5,8 x 3 x 7mm (10)	Kugelzapfen mit Flansch, 5,8 x 3 x 7 mm (10)	Rotule bridée, 5,8 x 3 x 7mm (10)	Sfera perno con flangia, 5,8 x 3 x 7 mm (10)
VTR334019	Front Carrier Set, Aluminum	Front-Trägersatz, Aluminium	Ensemble de support avant, aluminium	Supprto anteriore, alluminio
VTR334018	Front Spindle Set, Aluminum	Front-Spindelsatz, Aluminium	Ensemble d'axe avant, aluminium	Fusello anteriore, alluminio
VTR234030	Link Spacers, Aluminum, 3 x 6 x 12mm (8)	Stangen-Abstandshalter, Aluminium, 3 x 6 x 12 mm (8)	Entretoises de bras, 3 x 6 x 12 mm (8)	Distanziatori leveraggio, alluminio 3 x 6 x 12 mm (8)
VTR246008	Pivot Ball, 5,8 x 6mm (10)	Kugelzapfen, 5,8 x 6 mm (10)	Rotule, 5,8 x 6 mm (10)	Sfera perno 5,8 x 6 mm (10)
VTR334020	Rear Hub Carrier, Aluminum	Hinterer Nabenträger, Aluminium	Porte-moyeu arrière, aluminium	Supporto mozzo posteriore, alluminio
VTR43042	Wheel, F/R, 8 Spoke, Satin (4)	Rad, Front/Heck, 8 Speichen, Satin (4)	Roue, avant/arrière, 8 rayons, Satin (4)	Ruota A/R, 8 raggi, satinato (4)
VTR331009	Winch Fair Lead, Aluminum	Seilwindenführung, Aluminium	Guide-câble de treuil, aluminium	Cavo verricello, alluminio
VTR230056	72 Chevy K10 Pickup Cab Set Clear	Kabinensatz, 72er Chevy K10-Pickup, durchsichtig	Ensemble de cabine 72 Chevy K10 Pickup transparent	Set cab pickup 72 Chevy K10 trasparente
VTR230055	Ascender Roll Cage Set (290mm)	Ascender-Überrollkäfigsatz (290 mm)	Ensemble de cage de retournement Ascender (290 mm)	Set gabbia Ascender (290 mm)
DYNC0070	Charge Adapter: TAM Female to LOS Mini	Ladeadapter: Tamiya-Buchse auf Losi Mini	Adaptateur de charge : TAM Femelle à LOS Mini	Adattatore carica batteria: TAM femmina su LOS Mini
DYN5004	Charge Adapter Tamiya Female to Losi Mini	Ladeadapter: Tamiya-Buchse auf Losi Mini	Adaptateur de charge Tamiya Femelle à Losi Mini	Adattatore carica batteria femmina Tamiya su Losi Mini
SPM5000	DX5R 5CH DSMR Transmitter w/ SR6000T	DX5R DSMR 5-Kanal-Sender mit SR6000T	Émetteur DX5R 5 canaux DSMR avec SR6000T	Trasmittente DX5R 5 canali DSMR con SR6000T

**OPTIONAL PARTS LIST • OPTIONALE BAUTEILE • PIÈCES OPTIONNELLES • PEZZI OPZIONALI ////////////////**

Part #	English	Deutsch	Français	Italiano
VTR232008	High & Low Speed Gear Set	Satz mit Zahnrädern für hohe und niedrige Drehzahl	Ensemble d'engrenage de vitesse élevée et faible	Ingranaggi bassa e alta velocità
VTR234027	Suspension Rod Ends	Aufhängungsstangen-Endstücke	Embouts de bielle de suspension	Estremità asta sospensione
VTR232009	Tranny Shift Fork & Shaft	Getriebe-Schaltgabel und -welle	Fourchette et arbre de transmission	Forcella e albero cambio trasmissione
VTR232007	Tranny Shift Linkage Set	Getriebe-Schaltstangensatz	Ensemble de tringlerie de transmission	Leveraggio cambio trasmissione
VTR332009	Transmission Metal Gear Set	Metallgetriebesatz	Ensemble de boîte de transmission métallique	Ingranaggio in metallo trasmissione
VTR232017	Transmission Shaft Set	Getriebewellensatz	Ensemble d'arbre de transmission	Set albero trasmissione
VTR43018	TSL SX Swamper 1.9 Tire with Insert	TSL SX Swamper, 1,9-Zoll-Reifen mit Einsatz	Pneu TSL SX Swamper 1.9 avec Insert	Ruota TSL SX Swamper 1.9 con inserto
VTR232068	Center Transmission Gear Set & Spacers	Zahnrad und Abstandshaltersatz für zentrales Getriebe	Ensemble de boîte de transmission centrale et entretoises	Set ingranaggio trasmissione centrale e distanziatori

**EXPLODED VIEWS • EXPLOSIONSGRAFIKEN • VUES ÉCLATÉE • VISTE ESPLOSE ////////////////**

**BODY ASSEMBLY  
KAROSSERIE MONTAGE  
ASSEMBLAGE DU CORPS  
ASSEMBLEA DEL CORPO**

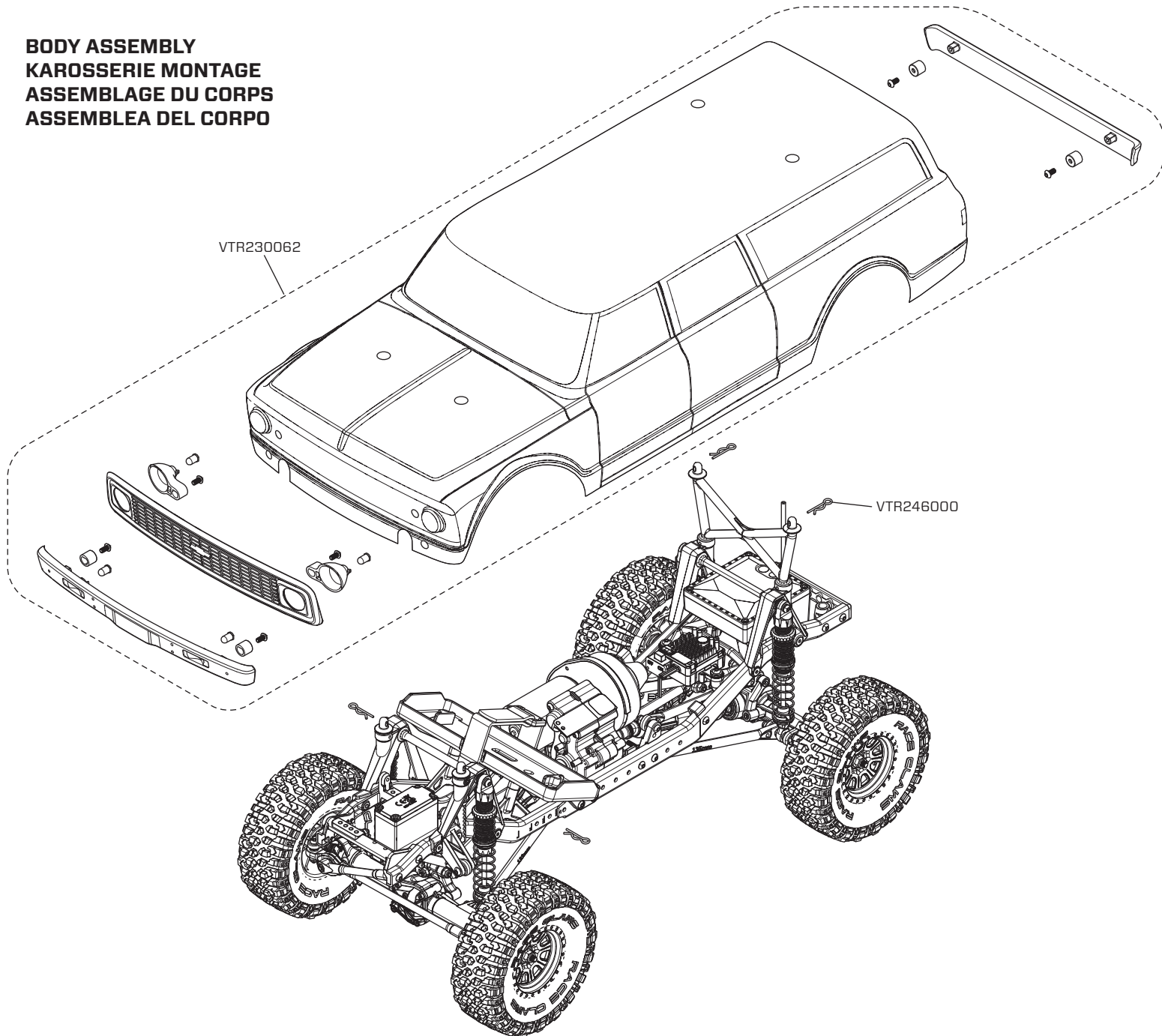

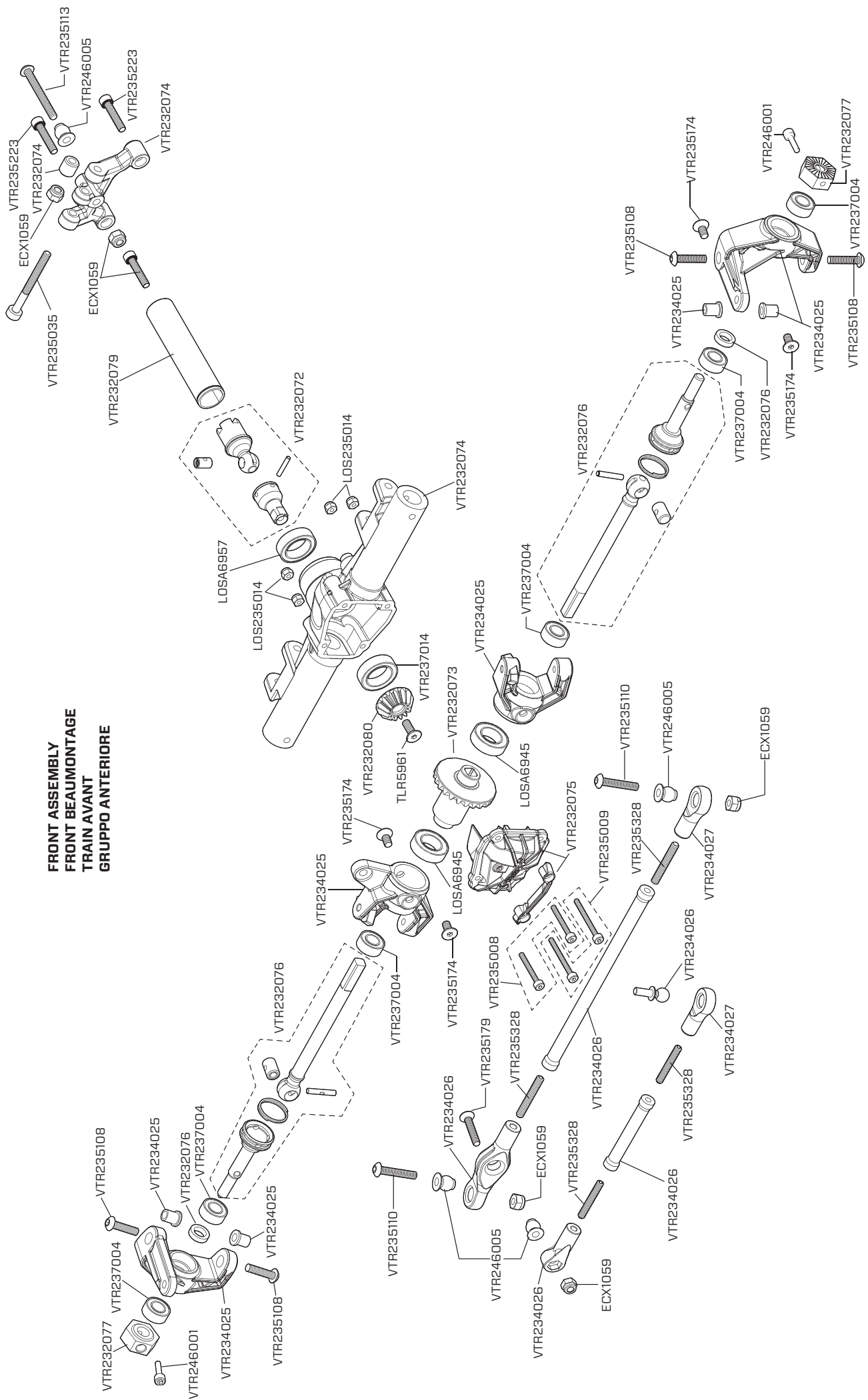

**FRONT ASSEMBLY  
FRONT BEAUMONTAGE  
TRAIN AVANT  
GRUPPO ANTERIORE**

- VTR235223
- VTR235113
- VTR232074
- VTR246005
- VTR235223
- VTR232074
- ECX1059
- VTR235035
- ECX1059
- VTR232079

- VTR232072
- LOS235014
- LOS235014
- VTR232074
- LOS235014
- LOS235014
- VTR237014
- VTR232073
- VTR234025
- VTR237004
- VTR232076
- VTR237004
- VTR232076
- VTR235108
- VTR234025
- VTR235174
- VTR246001
- VTR232077
- VTR237004

- LOSAG957
- LOS235014
- VTR237014
- VTR232073
- VTR234025
- VTR237004
- VTR232076
- VTR237004
- VTR232076
- VTR235108
- VTR234025
- VTR235174
- VTR246001
- VTR232077
- VTR237004

- VTR234025
- VTR235174
- VTR232073
- VTR234025
- VTR237004
- VTR232076
- VTR237004
- VTR232076
- VTR235108
- VTR234025
- VTR235174
- VTR246001
- VTR232077
- VTR237004

- VTR235108
- VTR237004
- VTR234025
- VTR232076
- VTR237004
- VTR234025
- VTR235108
- VTR235110
- VTR235179
- VTR235008
- VTR235174
- VTR235328
- VTR234026
- VTR235009
- VTR235328
- VTR234027
- VTR235110
- VTR246005
- VTR235328
- VTR234027

- VTR235110
- VTR246005
- VTR234026
- ECX1059
- VTR235328
- VTR234026
- VTR235328
- VTR234027

**FRONT UPPER LINK ASSEMBLY - WB2 (290mm)**  
**MONTAGE QUERLENKERARM VORNE OBEN - WB2 (290mm)**  
**ASSEMBLAGE DES TIRANTS SUPÉRIEURS AVANT - WB2 (290mm)**  
**GRUPPO BRACCETTO SUPERIORE SOSPENSIONE ANTERIORE - WB2 (290mm)**

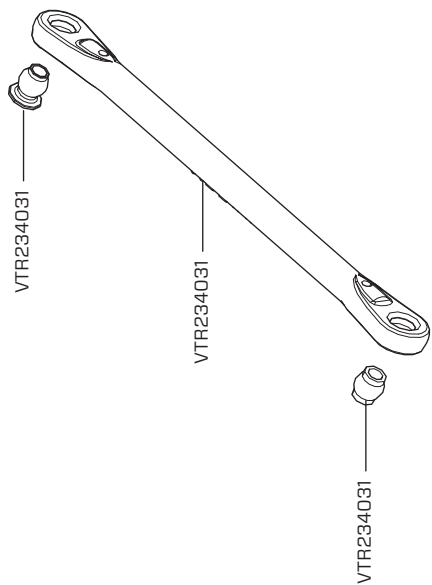

**FRONT LOWER LINK ASSEMBLY - WB2 (290mm)**  
**MONTAGE QUERLENKERARM VORNE UNTEN - WB2 (290mm)**  
**ASSEMBLAGE DES TIRANTS INFÉRIEURS AVANT - WB2 (290mm)**  
**GRUPPO BRACCETTO INFERIORE SOSPENSIONE ANTERIORE - WB2 (290mm)**

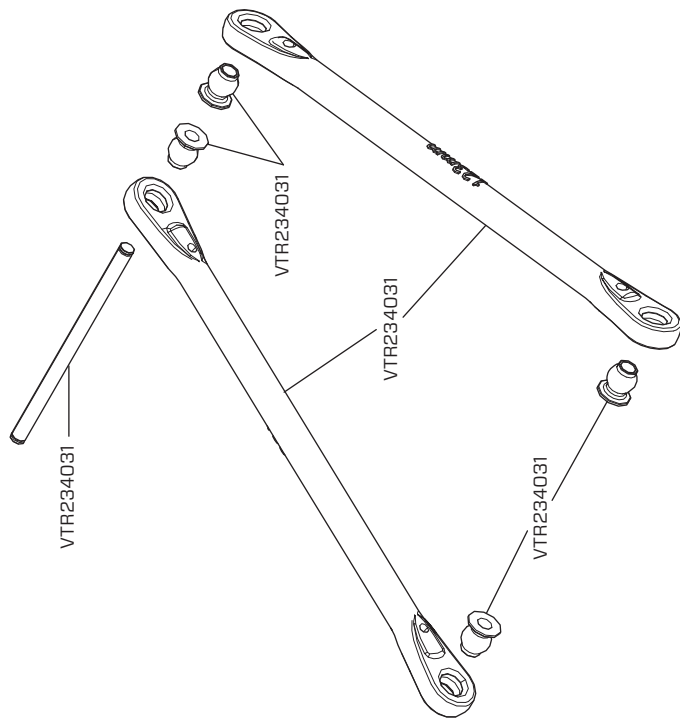

**REAR UPPER LINK ASSEMBLY - WB2 (290mm)**  
**MONTAGE QUERLENKERARM HINTEN UNTEN - WB2 (290mm)**  
**ASSEMBLAGE DES TIRANTS SUPÉRIEURS ARRIÈRE - WB2 (290mm)**  
**GRUPPO BRACCETTO SUPERIORE SOSPENSIONE POSTERIORE - WB2 (290mm)**

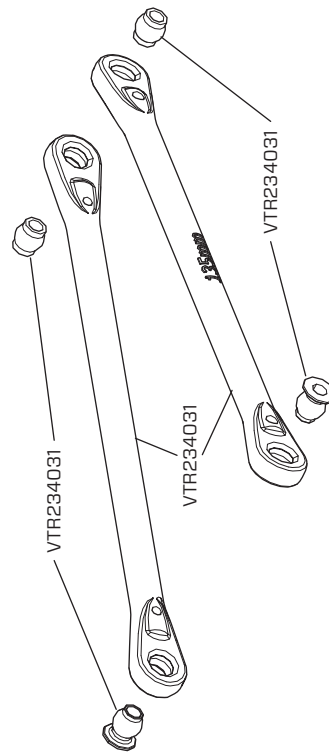

**REAR LOWER LINK ASSEMBLY - WB2 (290mm)**  
**MONTAGE QUERLENKERARM HINTEN UNTEN - WB2 (290mm)**  
**ASSEMBLAGE DES TIRANTS INFÉRIEURS ARRIÈRE - WB2 (290mm)**  
**GRUPPO BRACCETTO INFERIORE SOSPENSIONE POSTERIORE - WB2 (290mm)**

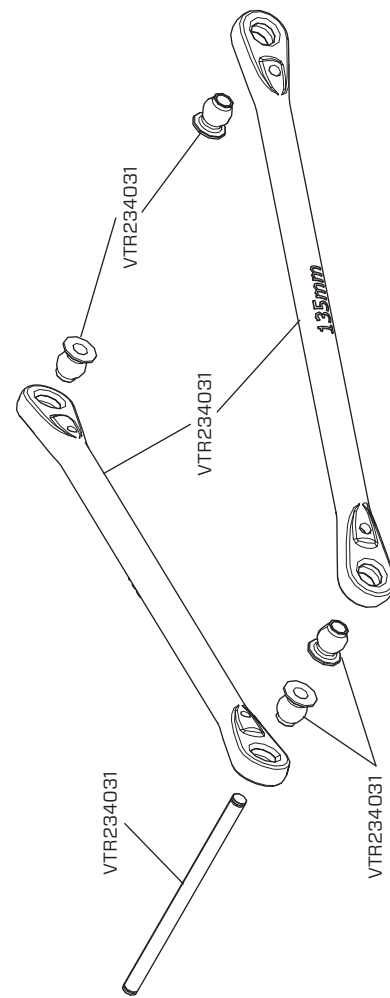



**TRANSMISSION ASSEMBLY  
MONTAGE GETRIEBE  
ASSEMBLAGE DE LA TRANSMISSION  
ASSEMBLAGGIO TRASMISSIONE**

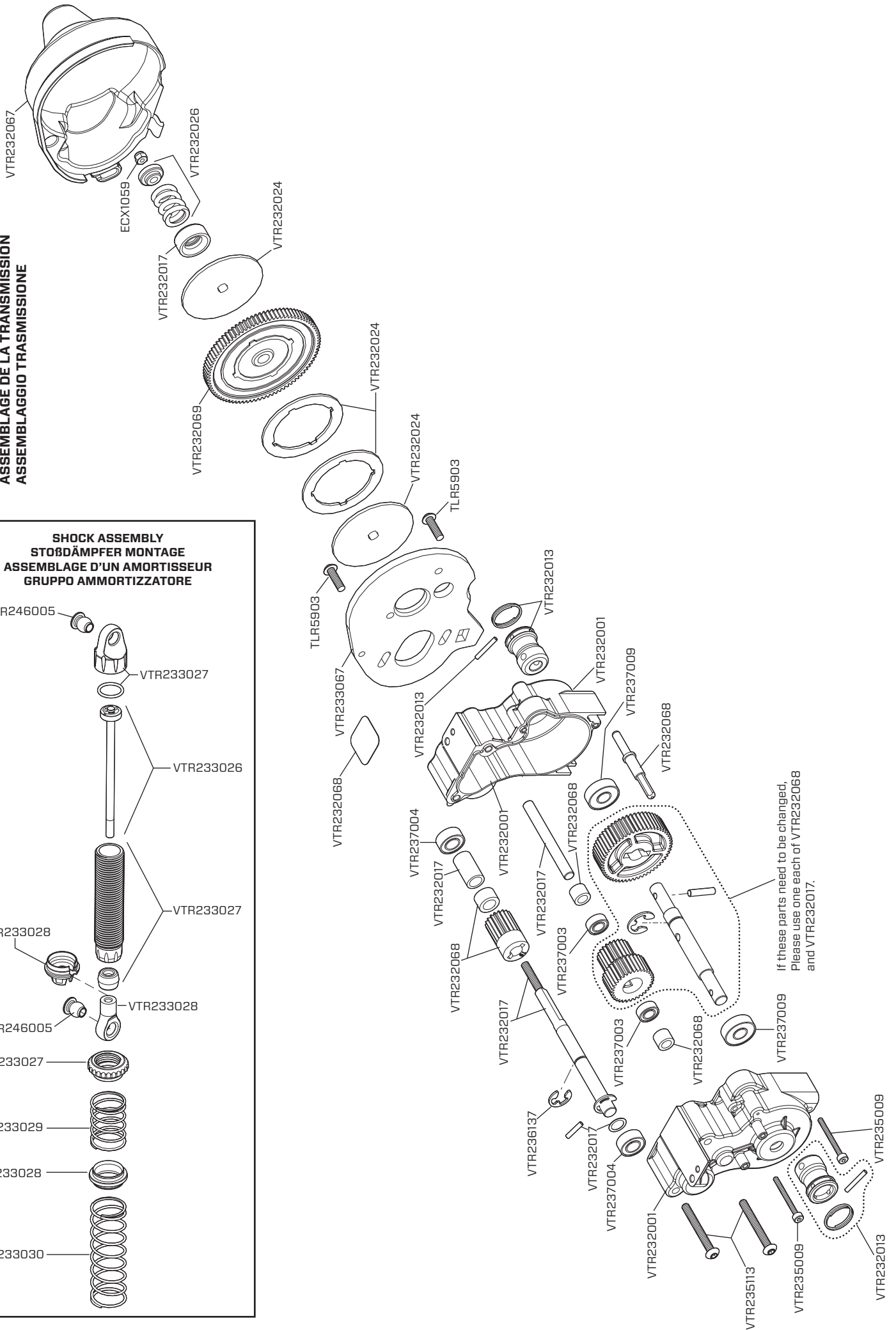
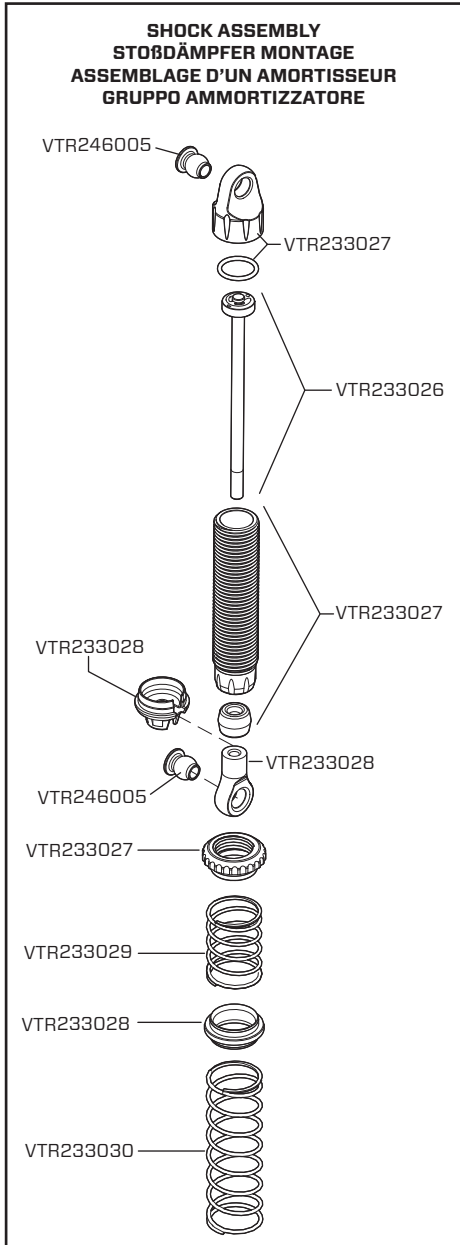



**MOTOR INSTALLATION  
MOTOREINBAU  
INSTALLATION DU MOTEUR  
INSTALLAZIONE DEL MOTORE**

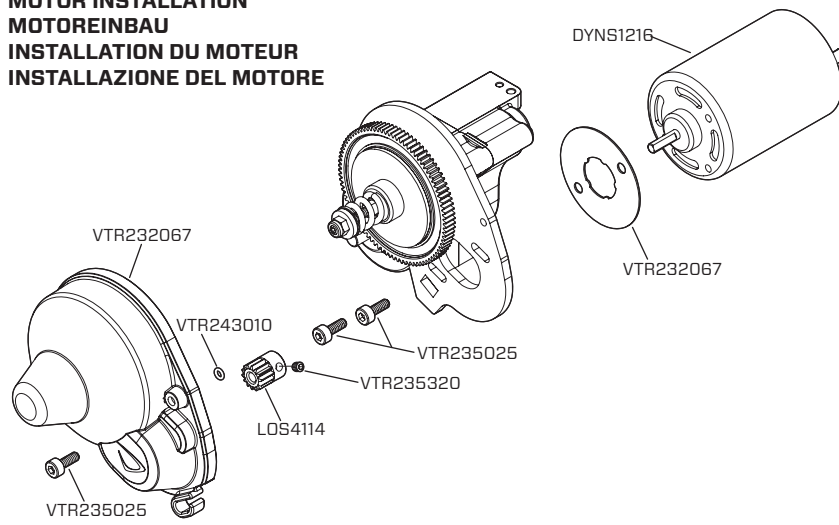

**BATTERY TRAY ASSEMBLY  
MONTAGE DES AKKUHALTERS  
ASSEMBLAGE DU SUPPORT DE BATTERIE  
GRUPPO SUPPORTO BATTERIA**

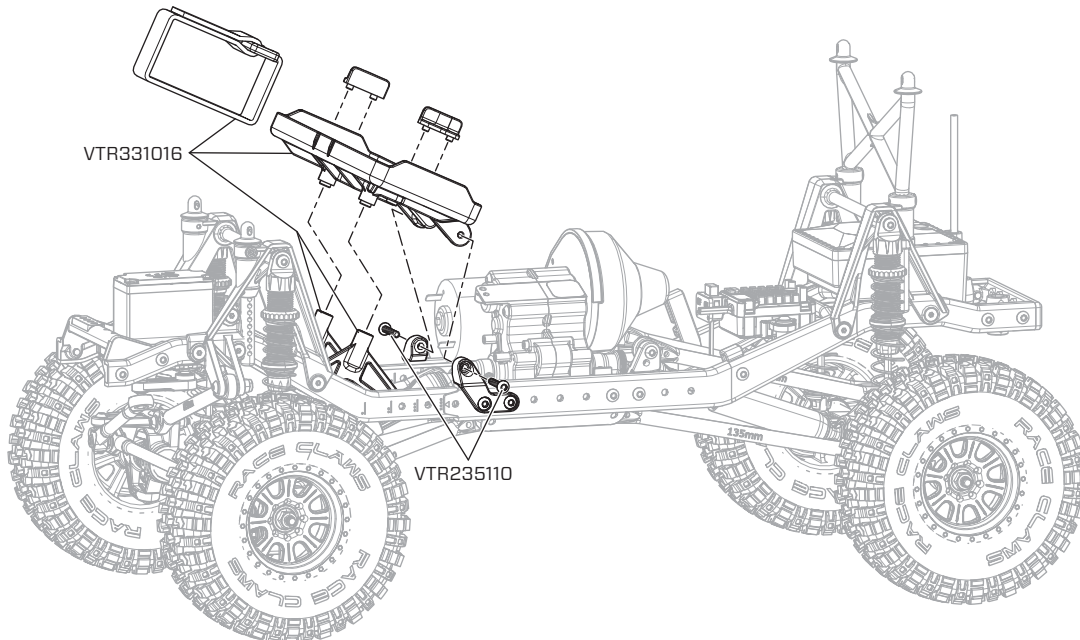

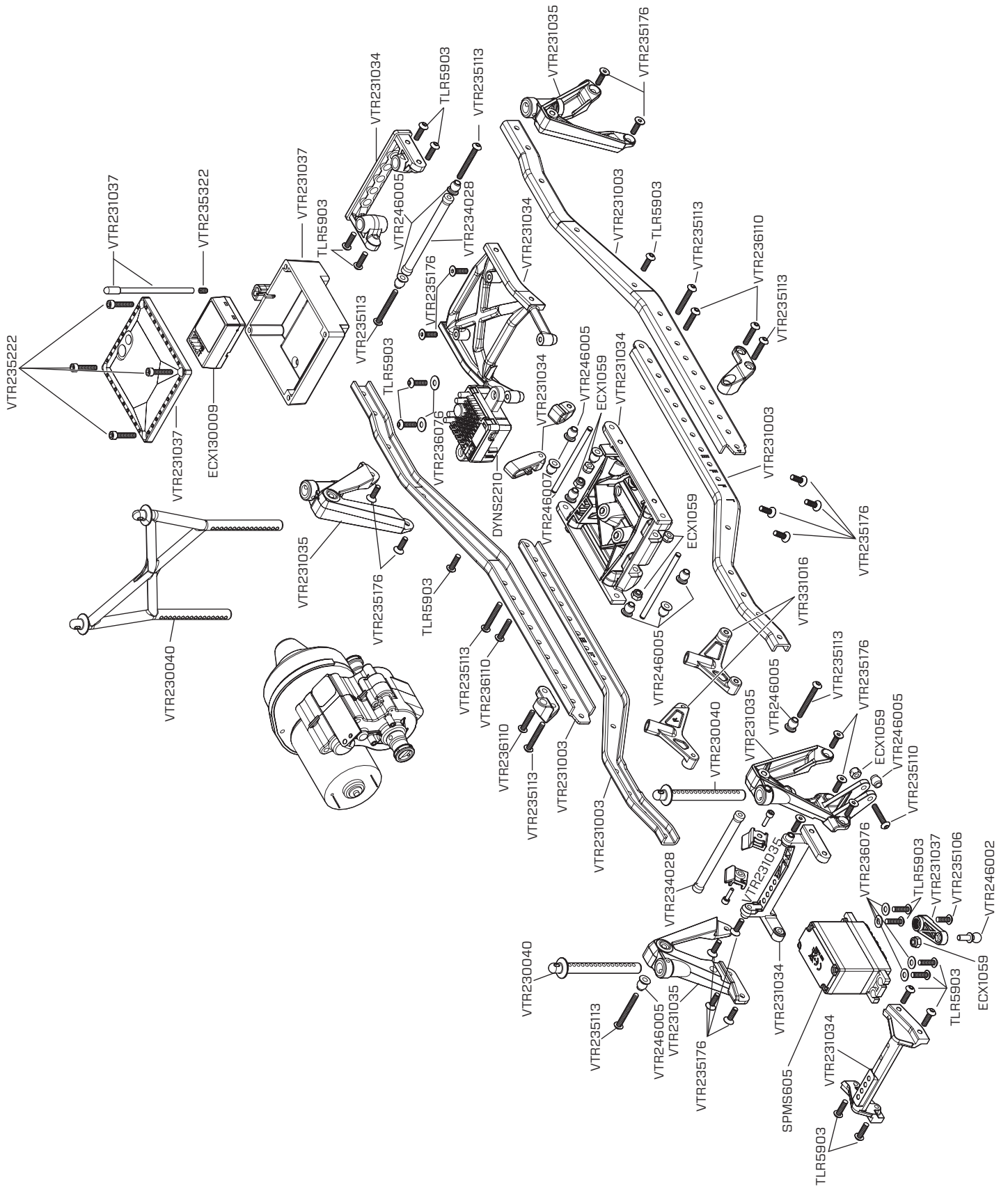

**CHASSIS**  
**CHASSIS**  
**CHASSIS**  
**TELAIO**



---

VATERRA®

---

It is a shared passion for motorsports and radio control. Extreme performance and extreme places. Cars and trucks that look and drive just like the real thing. Most of all, it is about gathering friends, grabbing a vehicle and having the time of your life.

---

**Adventure Driven.™**