



Ultra-Micro J-3 Cub RTF & BNF Instruction Manual

PKZ3900 RTF PKZ3980 BNF

© 2010 Horizon Hobby, Inc.
4105 Fieldstone Road
Champaign, IL 61822
USA

Horizon Hobby UK
Units 1-4, Ployters Road
Staple Tye
Harlow, Essex
CM18 7NS
United Kingdom

Horizon Hobby Deutschland GmbH
Hamburger Strasse 10
25335 Elmshorn
Germany

ParkZone® products are distributed exclusively by Horizon Hobby, Inc.

Multiple patents pending
US patent 7,391,320
US patent D578,146
PRC patent number ZL 2007 2 0069025.2

DSM and DSM2 are trademarks or registered trademarks of Horizon Hobby, Inc.
The Spektrum trademark is used with permission of Bachmann Industries, Inc.

Futaba is a registered trademark of Futaba Denshi Kogyo Kabushiki Kaisha Corporation of Japan.

www.parkzone.com
16438 Printed 11/09



RTF BNF™

Specifications
Length: 12.2 in (310mm)
Wingspan: 18.1 in (460mm)
Weight: 0.85 oz (24.0 g)
Battery: 3.7V 120mAh Lithium Polymer



Table of Contents

Specifications	1
J-3 Cub Introduction	3
Battery Warnings and Guidelines	4
Battery Charging	7
Additional Safety Precautions and Warnings	9
J-3 Cub RTF Contents	10
J-3 Cub BNF Contents	11
First Flight Preparation	12
Flying Checklist	12
Installing the Flight Battery	13
Transmitter and Receiver Binding	14
Transmitter Specific Binding Instructions	15
Transmitter Control Identification	17
Additional Binding Information	18
Control Test	19
Receiver Control Unit Description, Arming and Motor Control Test	23
Reversing Flight Controls	25
Stock Control Throw	26
Choosing a Flying Area	27
Flying the J-3 Cub	27
Replacing the Propeller	28
Replacing the Prop Shaft	29
Replacement Parts	31
Optional Parts	31
Troubleshooting Guide	32
Warranty Information	34
Compliance Information for the European Union	38

J-3 Cub Introduction

One of the most popular civilian aircraft of all time, the J-3 Cub is often seen around airshows and classic events today. Now indoor and backyard flyers can experience the fun of shooting touch and goes on a smaller scale with this incredible scale 3-channel reproduction from ParkZone.

This J-3 Cub offers classic Cub looks and performance in an ultra-micro sized package featuring Spektrum's 2.4GHz DSM2™ control. With a flying weight of only 0.85 oz (24.0 g), the J-3 can be flown at a gym or in your yard without having to make a trip to the flying field. The J-3 Cub is designed for experienced pilots that have previously flown 3-channel aircraft. Your J-3 comes 100% factory-assembled and is ready to fly with everything included (except a transmitter for BNF only). Also included in the box is the lithium polymer flight battery and convenient DC Li-Po battery charger, along with 4 AA batteries for the charger.

The DSM2 technology offers freedom from frequency restrictions and allows the J-3 Cub to be flown just about anywhere.

Although the J-3 Cub is nearly ready-to-fly right from the box, please take time to read through this manual for tips on battery safety and charging, control setup and more before making your first flight. It is important that you only charge the included 3.7V 120mAh 14C Li-Po battery (PKZ1035) with the included 1S 3.7V DC Li-Po Battery Charger (PKZ3240). You can also use the E-flite® Celectra™ 4-Port Charger (EFLC1004). This charger safely charges four 3.7V packs independently. Attempting to charge the battery using another Li-Po battery charger or non-Li-Po compatible charger could result in serious damage.

As the user of this product, you are solely responsible for operating it in a manner that does not endanger yourself and others or result in damage to the product or the property of others.

Product Registration

Register your product online at www.parkzone.com/register.

RTF
READY-TO-FLY

BNF
BIND-N-FLY™

Battery Warnings and Guidelines

While the 1S 3.7V DC Lithium Polymer Battery Charger (PKZ3240) included with your J-3 Cub has been specifically designed to safely charge the included 1S 3.7V 120mAh 14C Li-Po Battery (PKZ1035), you **MUST** read the following safety instructions and warnings before handling, charging or using the Li-Po battery.



Note: Li-Po batteries are significantly more volatile than the alkaline, Ni-Cd or Ni-MH batteries used in RC applications. All instructions and warnings must be followed exactly. Mishandling of Li-Po batteries can result in fire.

By handling, charging or using the included Li-Po battery you assume all risks associated with lithium batteries. If you do not agree with these conditions, return your complete J-3 Cub model in new, unused condition to the place of purchase immediately.

- You must charge the included 1S 3.7V 120mAh 14C Li-Po battery in a safe area away from flammable materials.
- Never charge the battery unattended. When charging the battery you should always remain in constant observation to monitor the charging process and react to potential problems that may occur.
- After flight, the battery must be cooled to ambient temperature before charging.
- **You MUST use the included 1S 3.7V DC Li-Po Battery Charger (PKZ3240). Failure to do so may result in a fire causing personal injury and/or property damage. You can use the E-flite Celecra 4-Port Charger (EFLC1004) to safely charge the 3.7V battery pack as well. DO NOT use an Ni-Cd or Ni-MH charger.**



- If at any time during the charge or discharge process the battery begins to balloon or swell, discontinue charging or discharging immediately. Quickly and safely disconnect the battery, then place it in a safe, open area away from flammable materials to observe it for at least 15 minutes. Continuing to charge or discharge a battery that has begun to balloon or swell can result in a fire. A battery that has ballooned or swollen even a small amount must be removed from service completely.
- Store the battery at room temperature in a dry area for best results.
- When transporting or temporarily storing the battery, the temperature range should be from 40–120 degrees Fahrenheit. Do not store the battery or model in a car or direct sunlight whenever possible. If stored in a hot car, the battery can be damaged or even catch fire.
- **Do not over-discharge the Li-Po flight battery. Discharging the battery too low can cause damage to the battery resulting in reduced power, duration or failure of the battery entirely. (See below for details.)**

Li-Po cells should not be discharged to below 3V each under load. In the case of the 1S Li-Po battery used for the J-3 Cub, you will not want to allow the battery to fall to below 3V during flight.

The J-3 Cub receiver unit features a soft low voltage cutoff (LVC) that occurs when the battery reaches 3V under load. When the soft cutoff occurs, the ESCs of the receiver unit will reduce power to the motor (regardless of the power level you have set with the throttle stick) in order to prevent the voltage of the battery from dropping below 3V. This reduction in power usually requires that you land the model immediately, at which point you should power down the model and unplug the flight battery. While it is possible to power the model up and to fly again after the soft LVC occurs, this is **NOT** recommended as this will over-discharge the battery. Continued discharging to the soft LVC will cause permanent damage to the Li-Po battery that results in lost power and duration when using the battery for subsequent flights, or failure of the battery entirely. Continued attempts to further discharge

the battery may also result in loss of control while the motor is running, as the voltage of the battery may drop below the minimum operating voltage of the receiver and other electronics.

Also, you should not fly to the soft LVC every time you fly. Instead, you should be aware of the power level of the battery/airplane throughout the flight, and if at any time the airplane begins to require more throttle than typical to maintain flight, you should land the airplane immediately. Routinely discharging the battery to the soft LVC can still cause permanent damage to the battery.

If you have any further questions or concerns regarding the handling, charging and/or use of the included Li-Po battery, please contact the Horizon Support Team at 877-504-0233, Horizon Hobby UK at +44 (0) 1279 641 097 or Horizon Technischer Service, Germany at +49 4121 46199 66.

Battery Charging

It is important that you charge the included 1S 3.7V 120mAh 14C Li-Po Battery (PKZ1035) with the included 1S 3.7V DC Li-Po Battery Charger (PKZ3240) or the E-flite Celectra 4-port Charger (EFLC1004). Attempting to charge the battery using another Li-Po charger or non-Li-Po compatible charger could result in serious damage. Please familiarize yourself thoroughly with the Battery Warnings and Guidelines section before continuing. Follow these steps to charge the Li-Po battery with the included charger.

- Remove the cover on the bottom of the charger and install four of the included AA batteries, noting proper polarity. Replace the cover after the AA batteries are installed.
- Slide the battery into the slot on the charger. The end cap of the battery has been specifically designed to allow the battery to be slid into the slot easily one way (usually with the label on the battery facing outward) to prevent reverse polarity connection. However, please be sure to check for proper alignment and polarity before proceeding to the next step.



- Gently press the battery and its connector into the charge jack/connector located at the bottom of the slot in the charger. Again, be sure to check for and to achieve proper polarity before making the connection.
- After you make the connection successfully, the LED light on the charger will turn solid red, indicating that charging has begun.

- It takes approximately 30–40 minutes to charge a fully discharged (not over-discharged) battery. As the battery nears full charge, the LED light will begin to blink. When the battery is fully charged, the LED light will blink approximately every 20 seconds or will go out entirely.

Note: The Li-Po battery included with your J-3 Cub will arrive partially charged. For this reason the initial charge may only take 15–20 minutes.

Note: You can expect to charge the Li-Po flight battery approximately 15–20 times before it will be necessary to replace the AA batteries in the charger. Replacing the included batteries with alkaline batteries will result in more charge cycles than with the included batteries.

Note: If LED remains on for longer than 40 minutes while charging and/or 5 seconds after removing the Li-Po flight battery, please replace the AA batteries in the charger.

Additional Safety Precautions and Warnings

This model is controlled by a radio signal that is subject to interference from many sources outside your control. This interference can cause momentary loss of control so it is advisable to always keep a safe distance in all directions around your model, as this margin will help avoid collisions or injury.

Age Recommendation: 14 years or over. This is not a toy. This product is not intended for use by children without direct adult supervision.

- Never operate your model with low transmitter batteries.
- Always operate your model in an open area away from cars, traffic, or people.
- Avoid operating your model in the street where injury or damage can occur.
- Never operate the model in the street or in populated areas for any reason.
- Carefully follow the directions and warnings for this and any optional support equipment (chargers, rechargeable battery packs, etc.) that you use.
- Keep all chemicals, small parts and anything electrical out of the reach of children.
- Moisture causes damage to electronics. Avoid water exposure to all equipment not specifically designed and protected for this purpose.
- Never lick or place any portion of your model in your mouth as it could cause serious injury or even death.

J-3 Cub RTF Contents

- J-3 Cub RTF airplane
- 2.4GHz DSM2 transmitter
- 120mAh 1S 3.7V 14C Li-Po battery
- 1S 3.7V Li-Po battery charger, 0.3A charge rate
- 8x AA batteries
- Landing gear

No additional equipment is needed for your J-3 Cub.



J-3 Cub BNF Contents

- J-3 Cub BNF airplane
- 120mAh 1S 3.7V 14C Li-Po battery
- 1S 3.7V Li-Po battery charger, 0.3A charge rate
- 4x AA batteries
- Landing gear

A DSM2 compatible aircraft transmitter is required to complete your J-3 Cub.



First Flight Preparation

Please note this checklist is not intended to be a replacement for the content included in this manual. Although it can be used as a quick start guide, we strongly suggest reading through this manual completely before proceeding.

- Remove and inspect contents
- Install landing gear into the plastic landing gear mounts on the bottom of the wing
- Install 4 AA batteries into the battery charger
- Begin charging the flight battery
- Install batteries in the transmitter (as required)
- Test the controls
- Familiarize yourself with the controls
- Find a suitable area for flying

Flying Checklist

- Always turn on the transmitter first
- Plug the flight battery into the lead from the receiver
- Allow the receiver to initialize and arm properly
- Fly the model
- Land the model
- Unplug the flight battery from the receiver
- Always turn off the transmitter last

Installing the Flight Battery

Once the Li-Po battery has been fully charged, it's ready to be installed in the airplane.

Install the battery in the airplane by placing it into the slot on the bottom of the fuselage with the plug facing toward the front of the airplane.

Note: If you are using E-flite mCX batteries or other batteries without hook and loop tape, we have included extra hook and loop tape pieces to allow you to use these batteries.



Transmitter and Receiver Binding

Your J-3 Cub RTF comes pre-bound to the included MLP4DSM transmitter. If you should need to re-bind your airplane follow the simple directions below.

Setting the Airplane for Binding:

1. Make sure the flight battery is disconnected from the receiver unit and the transmitter is turned off.
2. Plug in the flight battery into the airplane. When the LED on the receiver begins to flash (can be seen by looking through the opening at the rear of the battery cavity), then immediately proceed to instructions for your transmitter below.

Note: Although the transmitter included in your J-3 RTF is 4-channel capable, the airplane is a 3-channel aircraft with proportional throttle, elevator, and rudder control. For this reason, the rudder control is on the right stick.

Binding is the process of programming the receiver of the control unit to recognize the GUID (Globally Unique Identifier) code of a single specific transmitter. It will be necessary for you to 'bind' your chosen Spektrum DSM2 technology equipped transmitter to the receiver for proper operation. The following is a list of some of the Spektrum DSM2-equipped transmitters and modules that will bind to the receiver of the J-3 Cub.

ParkZone Vapor/Ember 2 Transmitter	
E-flite LP5DSM	E-flite MLP4DSM
JR 12X 2.4	JR X9303 2.4
Spektrum DX5e	Spektrum DX6i
Spektrum DX7/DX7se	

Note: The Spektrum DX6 (SPM2460) is equipped with DSM (not DSM2) technology and is not compatible with the receiver of the J-3 Cub BNF.

Transmitter Specific Binding Instructions

MLP4DSM, Vapor, Ember2, P-51 Transmitter:

1. When you see the LED on the receiver begin to flash while looking through the opening at the back of the battery cavity of the J-3 Cub, push the left stick of the transmitter inward into the case (NOT pulling down on throttle stick) until you hear it click.
2. While pushing the stick in, power on the transmitter, release stick once the transmitter is powered on. The transmitter will beep and the LED on the face of the transmitter will pulse.
3. Once the transmitter stops beeping it will take a second or two to connect with the airplane.

Note: It can be difficult at times to see the LED blink (indicating you are in bind mode), therefore slowly count to five once you have connected the battery and the airplane should enter bind mode at that time.



DX5e:

1. To bind your J-3 to the DX5e, move the sticks and switches on the transmitter to the desired failsafe positions (low throttle and neutral control positions).
2. Pull and hold the Trainer Switch on the transmitter while turning the transmitter on. Release the trainer switch once the LEDs on the front of the transmitter flash.
3. The LED on the receiver will go solid red and the system will connect after several seconds.

DX6i:

1. To bind your J-3 to the DX6i, plug the battery into the receiver of the airplane. The LED on the receiver will begin flashing.
2. Move the sticks and switches on the transmitter to the desired failsafe positions (low throttle and neutral control positions).
3. Pull and hold the Trainer Switch on the transmitter while turning the transmitter on. Release the trainer switch once the word BIND flashes on the LCD screen on the front of the transmitter.
4. The LED on the receiver will go solid red and the system will connect after several seconds.

DX7, DX7se, X9303, or 12X:

1. To bind your J-3 Cub to the DX7, DX7se, X9303 or 12X, plug the battery into the receiver of the airplane. The LED on the receiver will begin flashing.
2. Move the sticks and switches on the transmitter to the desired failsafe positions (low throttle and neutral control positions).
3. Press the bind button on the back of the transmitter while turning the transmitter on. The bind button on the back of the transmitter will flash. Release the button after 2–3 seconds.
4. The LED on the receiver will go solid red and the system will connect after several seconds.

The transmitter is now bound to the airplane. If you encounter any problems, repeat the binding process again, see the troubleshooting guide or call the Horizon Support Team at 877-504-0233, Horizon Hobby UK at +44 (0) 1279 641 097 or Horizon Technischer Service, Germany at +49 4121 46199 66.

Transmitter Control Identification

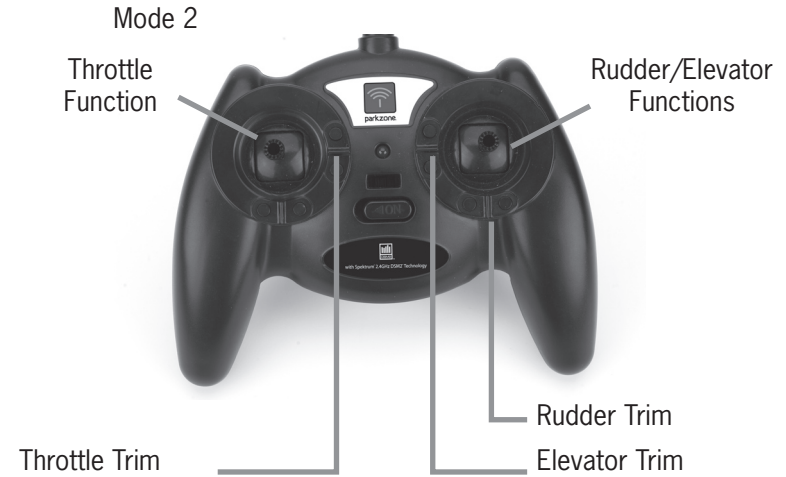

Note: Before each flight you should ALWAYS turn the transmitter on before connecting the flight battery to the receiver unit. After each flight, be sure that you always disconnect the flight battery from the receiver unit before powering the transmitter off.

Additional Binding Information

Prior to each flight, power on your transmitter and wait about five seconds before you plug the flight battery into the receiver. Doing this allows time for the transmitter to scan and secure two open frequencies. If the flight battery is plugged in too quickly and the link is missed, it may cause the receiver to inadvertently enter bind mode. If this occurs simply leave the transmitter on, then disconnect and reconnect the flight battery.

Control Test

You must test the controls prior to the first flight to ensure none of the servos, linkages or parts were damaged during shipping and handling and that the controls function in the correct directions.

Turn the transmitter on first and lower the throttle stick completely. Then, plug the battery into the battery lead of the receiver unit.

Note: The connectors on the battery and battery lead are keyed to prevent reverse polarity connection. However, if you force them together in the wrong orientation and with the wrong polarity it is still possible to damage the battery and/or receiver unit. To help further prevent a reverse polarity connection, one side of the end cap on the battery and the connector on the battery lead of the receiver unit will have a red dot. The connectors are oriented for a proper polarity connection when the red dots are on the same side.

Move the elevator stick on the transmitter forward and aft to check elevator pitch control. When the stick is pushed forward, the elevator should move down.

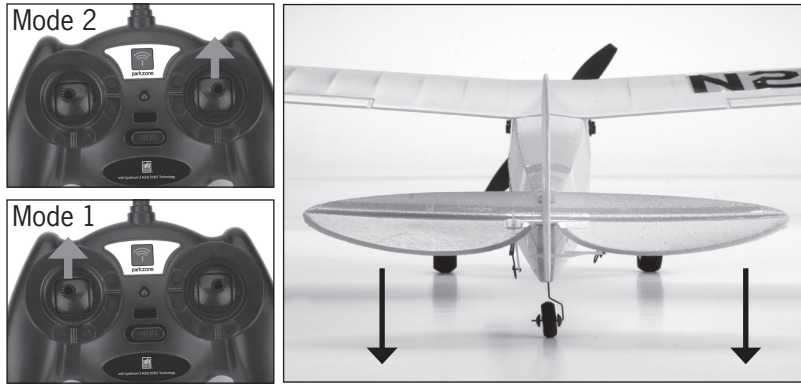

When the elevator stick is moved aft, the elevator should move up.



Move the rudder stick left and right to check yaw control. When the stick is pushed to the right, the rudder should also move to the right.

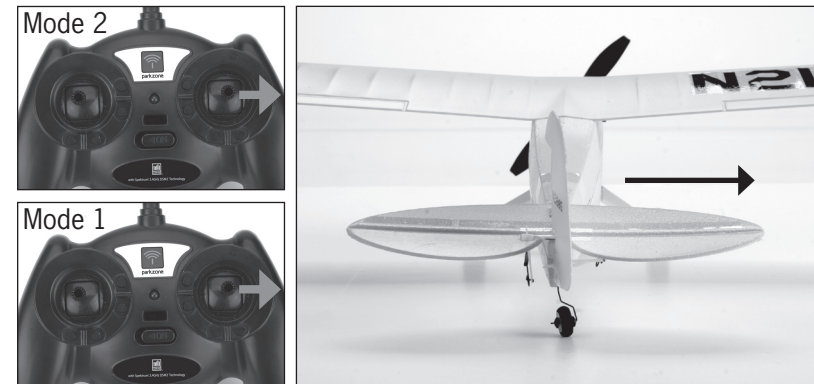

With the rudder stick pushed to the left, the rudder should move to the left.

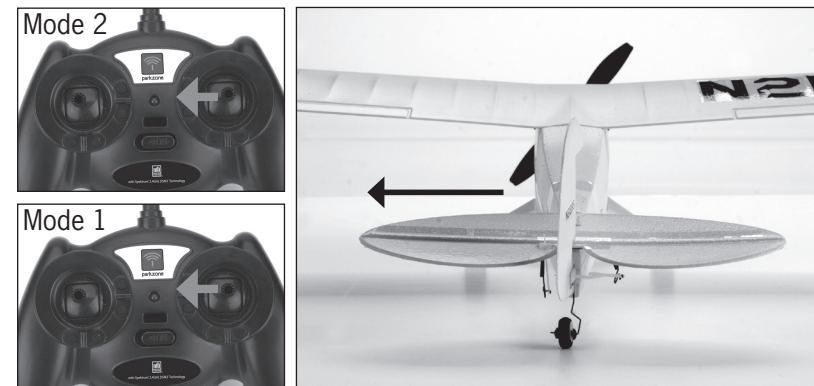

If at any time during the test the controls respond in the opposite direction, it may be necessary to reverse/change the direction of operation of the flight controls. Follow the Reversing Flight Controls section to change the direction of the various flight controls.

Once you've reconfirmed the flight control directions, all controls should be functioning properly. However, if you continue to encounter any problems with your J-3 Cub responding properly to the transmitter, do not fly. Call the Horizon Support Team at 1-877-504-0233, Horizon Hobby UK at +44 (0) 1279 641 097 or Horizon Technischer Service, Germany at +49 4121 46199 66.

Digital Trims

The ParkZone 4-channel 2.4GHz DSM2 transmitter features digital trims on all controls to make fine adjustments. Center the control surfaces using the trims. If there is not enough electronic trim available, it may be necessary to adjust the loops in the control linkages to center the surfaces.

Transmitter Dual Rate Function (RTF Only)

The 4-channel 2.4GHz DSM2 transmitter included with the J-3 Cub features dual rate capability. The default setting is high rate. To access the low rate function, simply press IN on the right gimbal. The LED light on the transmitter face will begin to blink, alerting you that the transmitter is on low rate. To return to high rate, simply push in again on the right gimbal.

Note: ParkZone STRONGLY recommends using the LOW RATE setting for conducting the first flights of your J-3 Cub.

Receiver Control Unit Description, Arming and Motor Control Test

The receiver installed on your J-3 Cub is a lightweight combination of main motor electronic speed control, servos and Spektrum DSM2 compatible receiver. The receiver unit is also equipped with a status indicator LED.

Before each flight ALWAYS turn the transmitter on before connecting the flight battery to the receiver unit. Never connect the flight battery to the receiver unit before powering the transmitter on first. After each flight, always disconnect the flight battery from the receiver unit before powering the transmitter off.

Note: The only time you should connect the flight battery to the receiver unit before powering the transmitter on is when you are binding the receiver of the receiver unit to the transmitter. Please see the Transmitter and Receiver Binding section of this manual for more information.

The following checklist contains the steps you must follow to ensure proper arming and operation of the receiver unit, as well as proper motor response.

- The throttle stick MUST be set in the lowest possible position, and, for most transmitters, the throttle trim must also be set to the lowest possible position in order for the receiver unit to arm. If this is the first test flight, or a test flight following repairs, you should also center the rudder, aileron and elevator trims.
- When the status LED on the receiver becomes solid red, the receiver unit is initialized and ready for flight. Also, as long as you had the throttle stick in the idle position and the throttle trim in the lowest position during the initialization process, the ESC/motor will now be armed. Use caution as the propeller will now spin with throttle stick input.

Note: If the status LED of the receiver does not become solid red, please review the following.

- If after blinking red the status LED becomes solid red, but you have no control of the motor, you have a positive Radio Frequency (RF) link between the transmitter and receiver, but the throttle stick and throttle trim may not be set to

the correct positions. Check that the throttle stick is in the lowest possible position, and that the throttle trim is set to the middle or a lower-than-the-middle position. If you now have control of the motor, proceed to the next step of the checklist.

If the blinking red status LED keeps flashing, you do not have a positive RF link between the transmitter and receiver. Check to be sure that the transmitter has been powered on and that the LED indicator on the transmitter is glowing solid red. If the transmitter is powered on and functioning properly, disconnect the flight battery from the receiver unit, then reconnect it. Now the receiver unit should initialize and arm properly.

Note: In the event you inadvertently enter Bind Mode, the LED on the receiver will flash red continuously. If this occurs, cycle the flight battery while the transmitter is on (if previously bound). If your receiver unit will not initialize and arm after following the guidelines as listed above, call the Horizon Support Team at 1-877-504-0233, Horizon Hobby UK at +44 (0) 1279 641 097 or Horizon Technischer Service, Germany at +49 4121 46199 66.

Once you have placed the airplane in a safe area, free of obstructions, and are clear of the propeller, you can safely begin to power up the model to check for proper operation of the motor.

- Advance the throttle stick upward slowly, just until the propeller begins to spin. DO NOT attempt to fly the airplane at this time. Note the direction the propeller spins. If viewed from the front of the airplane, the propeller will spin counterclockwise. If it is spinning backwards, disconnect the battery and reverse the polarity of the motor's input power leads.

Reversing Flight Controls

The transmitter included with the RTF J-3 Cub is the same transmitter that is included in the PKZ Ember 2, Vapor, and Ultra-Micro P-51 RTF versions. It also functions identically to the transmitter included with the E-flite Blade® mCX and mSR (MLP4DSM).

Note: For reversing with other transmitters, please refer to that transmitter's instruction manual.

Should the J-3 Cub's electronic components be used in another aircraft, you may find it necessary to reverse the operation of flight control surfaces.

Reversing the rudder and elevator operation can be accomplished by following the steps below.

1. Be certain that the battery is unplugged from the aircraft and the transmitter is turned off.
2. Push down on the digital trim button for the surface you would like to reverse.
 - a. Top elevator trim button—elevator normal
 - b. Bottom elevator trim button—elevator reverse
 - c. Left rudder trim button—rudder normal
 - d. Right rudder trim button—rudder reverse
3. Continue holding the desired digital trim button down and turn the transmitter on.
4. Hold the digital trim buttons down for approximately five seconds until tones are heard, confirming the selection.
5. Connect the flight battery and complete the flight control test, confirming that all surfaces are operating in the correct direction.

Stock Control Throw

Out of the box, your J-3 should have the approximate control throws. In production, this can vary by approximately 2mm without any effect on flight performance.

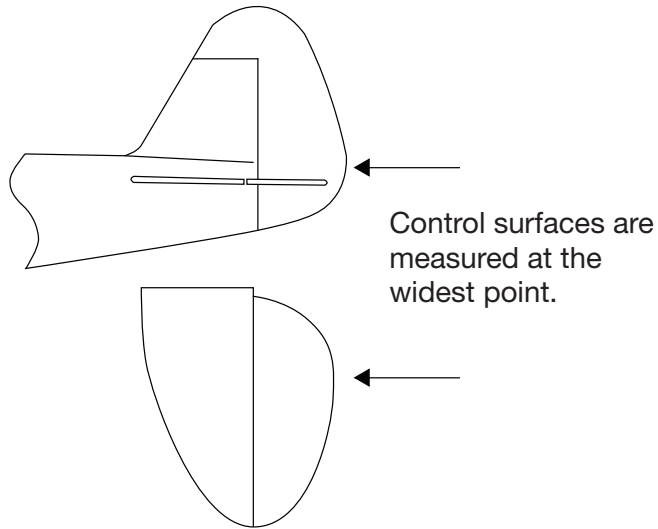

	High Rate	Low Rate
Elevator:	4mm up/down	3mm up/down
Rudder:	6mm left/right	4mm left/right

With the battery installed, the center of gravity is approximately 22mm as measured back from the leading edge of the wing. This can vary by approximately 1 to 2mm.

Choosing a Flying Area

When you are ready for your first flight, you will want to select a relatively open area, the size of a basketball court or larger, that is free of people and obstructions with calm wind (if flown outdoors). Once you have properly trimmed your airplane and become familiar with its handling and capabilities, you will be able to fly in other smaller, less open areas.

Flying the J-3 Cub

Start first flight using the low rate settings to become familiar with the flying characteristics before increasing the throw of the control surfaces.

Place the J-3 Cub in position for takeoff (facing into the wind if flying outdoors). Gradually increase the throttle to $\frac{3}{4}$ to full, and steer with the rudder. Pull back gently with the elevator and climb to check trim. Once the plane is trimmed, you can begin exploring the flight envelope of the J-3 Cub.

IN THE UNFORTUNATE EVENT OF A CRASH OR PROPELLER STRIKE, NO MATTER HOW MINOR OR MAJOR, YOU MUST LOWER THE THROTTLE STICK AND TRIM TO THEIR LOWEST POSSIBLE POSITIONS AS QUICKLY AS POSSIBLE TO PREVENT DAMAGE TO THE ESC OF THE RECEIVER UNIT.

Failure to lower the throttle stick and trim to the lowest possible positions in the event of a crash could result in damage to the ESC in the receiver unit, which may require replacement of the receiver unit.

Note: Crash damage is not covered under the warranty.

Replacing the Propeller

The propeller is threaded onto the shaft of the gearbox.

1. To remove the propeller, use needle-nose pliers or hemostats to grip the prop shaft.



2. Spin the propeller counterclockwise (if viewed from the front) to remove the old propeller.



3. Thread the new 100mm x 60mm prop and spinner clockwise onto the gearbox shaft.

Replacing the Prop Shaft

You may find that you need to replace the prop shaft in the gearbox should it become damaged. To replace the prop shaft:

1. To remove prop shaft, open the fuselage by cutting through the decal on one side of the fuselage. Remove the plastic dummy engine by gently pulling off the fuselage.

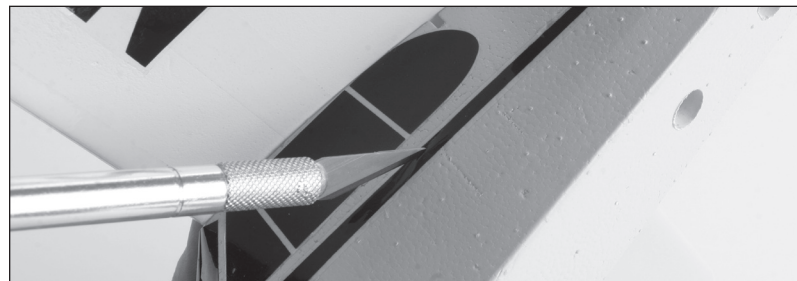

2. Gently grasp the white nylon nut located at the back of the prop shaft to prevent it from turning.

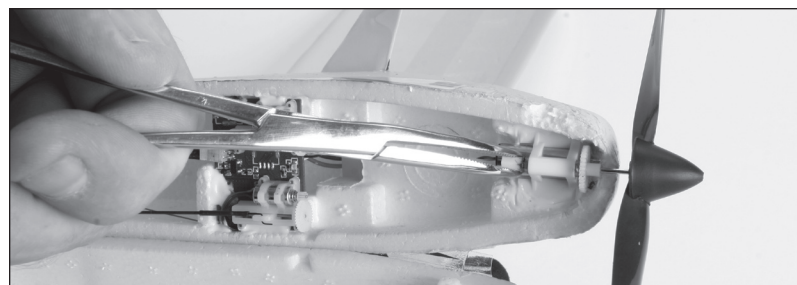

3. While holding the nylon nut, rotate the spur gear in a clockwise direction. The prop shaft will thread out of the nut.



4. Gently pull on the spur gear and the prop shaft will slide out of the gearbox. You may need to cut away a small portion of foam to allow the spur gear to slide forward out of the gearbox.
5. Thread the 100mm x 60mm prop and spinner on to the new prop shaft by holding the spur gear and turning the prop clockwise.
6. Slide the new prop shaft back into the gearbox.
7. Place the nylon nut on the back of the prop shaft. Spin the prop and spur gear counterclockwise. The nylon nut will thread onto the prop shaft.

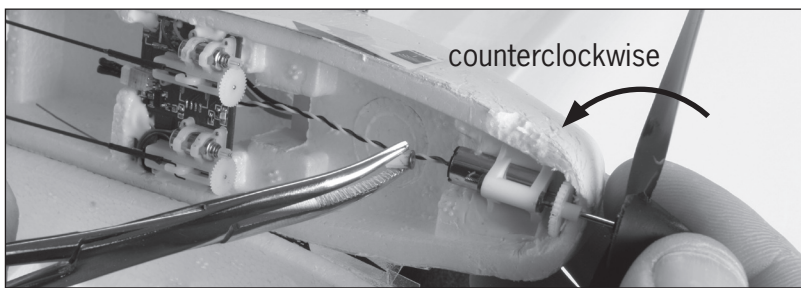

8. While holding the nylon nut in place, gently turn the spur gear counterclockwise to ensure the nut is snug.
9. Tape the fuselage back together with clear tape. Use foam-safe CA and reattach the dummy motors on each side of the fuselage.

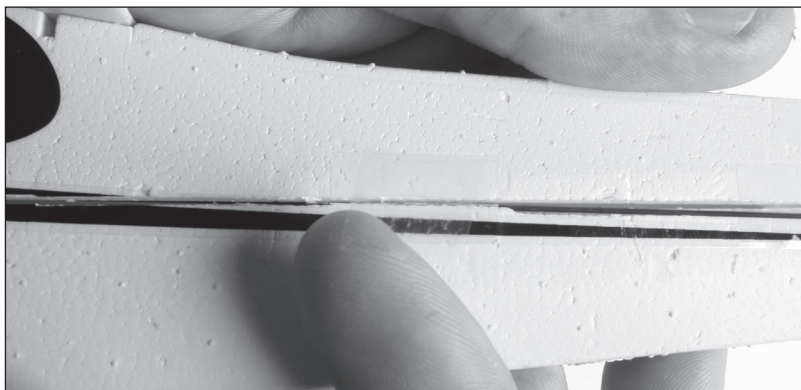

Replacement Parts

PKZ1035	120mAh 1S 3.7V Li-Po Battery
PKZ3901	Prop with Spinner: 100 x 60mm
PKZ3903	Decal Sheet
PKZ3904	Prop Shaft with Nut
PKZ3906	Main Landing Gear Set
PKZ3907	Tail Gear Set
PKZ3916	6mm Motor
PKZ3920	Wing
PKZ3922	Pushrod Set
PKZ3924	Complete Tail
PKZ3928	Complete Gearbox
PKZ3967	Bare Fuselage
PKZ3968	Fuselage with Electronics
PKZ3351	Receiver/ESC Board

Optional Parts

PKZ3341	2.4GHz DSM2 4-Channel Transmitter
EFLA209	E-flite Foam-Safe CA (medium)
EFLA208	E-flite Foam-Safe Activator
EFLC1004AC	E-flite Celectra 4-Port Charger with AC Adapter
SPMR5500	Spektrum DX5e Transmitter (Mode 2)
SPMR6600	Spektrum DX6i Transmitter (Mode 2)

Note: For minor repairs use foam-safe CA (EFLA209) or clear tape.

Troubleshooting Guide

Problem	Possible Cause	Solution
<p>RTF/BNF</p> <p>Aircraft will not “throttle up” but all other controls seem to function.</p> <p>BNF Only</p>	<ul style="list-style-type: none"> User did not lower throttle trim and throttle stick prior to initializing the aircraft. Throttle channel is reversed. Note: Futaba transmitters (equipped with Spektrum modules) may require you to reverse the throttle channel. 	<ul style="list-style-type: none"> Lower throttle stick and throttle trim to their lowest settings. Reverse throttle channel on specific transmitter if applicable.
<p>RTF/BNF</p> <p>Propeller or motor shaft broken.</p>	<ul style="list-style-type: none"> Crash damage 	<ul style="list-style-type: none"> Replace with PKZ3601 Prop with Spinner: J-3 Cub, or PKZ3528 Prop Shaft: J-3 Cub.
<p>RTF/BNF</p> <p>Aircraft appears to show significant decrease in flight time.</p> <p>Aircraft appears to have less power.</p>	<ul style="list-style-type: none"> Flight battery is not fully charged. AA batteries in charger have inadequate power. PKZ1035 battery has been over-discharged multiple times, causing damage to battery life. Bushings on gearbox may be causing friction, reducing power. 	<ul style="list-style-type: none"> Recharge flight battery completely. Replace AA batteries in the charger and recharge flight battery completely. Replace PKZ1035 battery and read “Battery Warnings and Guidelines” section of manual. Pages 4–6. Lubricate the bushings of the gearbox.
<p>RTF/BNF</p> <p>Charger light stays on after Li-Po battery is disconnected or remains on for longer than 40 minutes when charging.</p>	<ul style="list-style-type: none"> AA batteries in the charger have inadequate power. 	<ul style="list-style-type: none"> Replace AA batteries in the charger.

Problem	Possible Cause	Solution
<p>RTF/BNF</p> <p>LED on Aircraft remains flashing and cannot be controlled by transmitter.</p> <p>BNF Only</p>	<ul style="list-style-type: none"> User did not wait at least 5 seconds after powering the transmitter prior to connecting the flight battery to the Aircraft. Transmitter was too close to Aircraft during the initialization process. User bound the Aircraft to a different transmitter. 	<ul style="list-style-type: none"> Unplug, then reconnect flight battery. Move transmitter (powered on) a few feet from the Aircraft prior to reconnecting the flight battery. Rebind Aircraft to your desired compatible transmitter.
<p>Aircraft appears to roll, yaw, or pitch toward a certain direction.</p>	<ul style="list-style-type: none"> User did not re-trim the Aircraft. 	<ul style="list-style-type: none"> Trim control surface using the transmitter until airplane no longer moves that direction.
<p>BNF Only</p> <p>Controls appear to be reversed after binding to a different transmitter.</p>	<ul style="list-style-type: none"> User did not initially set up the transmitter prior to binding to the Aircraft. 	<ul style="list-style-type: none"> Read “Control Test” section of this manual. Pages 24–27.
<p>RTF/BNF</p> <p>Aircraft does not function after connecting flight battery and aircraft smells burnt.</p>	<ul style="list-style-type: none"> User may have accidentally plugged the flight battery in the wrong polarity. 	<ul style="list-style-type: none"> Replace receiver/ESC board (PKZ3351) and ensure the RED polarity marks are facing the same direction when connecting the flight battery to the receiver board.

Warranty Information

Warranty Period

Exclusive Warranty- Horizon Hobby, Inc., (Horizon) warrants that the Products purchased (the "Product") will be free from defects in materials and workmanship at the date of purchase by the Purchaser.

Limited Warranty

(a) This warranty is limited to the original Purchaser ("Purchaser") and is not transferable. REPAIR OR REPLACEMENT AS PROVIDED UNDER THIS WARRANTY IS THE EXCLUSIVE REMEDY OF THE PURCHASER. This warranty covers only those Products purchased from an authorized Horizon dealer. Third party transactions are not covered by this warranty. Proof of purchase is required for warranty claims. Further, Horizon reserves the right to change or modify this warranty without notice and disclaims all other warranties, express or implied.

(b) Limitations- HORIZON MAKES NO WARRANTY OR REPRESENTATION, EXPRESS OR IMPLIED, ABOUT NON-INFRINGEMENT, MERCHANTABILITY OR FITNESS FOR A PARTICULAR PURPOSE OF THE PRODUCT. THE PURCHASER ACKNOWLEDGES THAT THEY ALONE HAVE DETERMINED THAT THE PRODUCT WILL SUITABLY MEET THE REQUIREMENTS OF THE PURCHASER'S INTENDED USE.

(c) Purchaser Remedy- Horizon's sole obligation hereunder shall be that Horizon will, at its option, (i) repair or (ii) replace, any Product determined by Horizon to be defective. In the event of a defect, these are the Purchaser's exclusive remedies. Horizon reserves the right to inspect any and all equipment involved in a warranty claim. Repair or replacement decisions are at the sole discretion of Horizon. This warranty does not cover cosmetic damage or damage due to acts of God, accident, misuse, abuse, negligence, commercial use, or modification of or to any part of the Product. This warranty does not cover damage due to improper installation, operation, maintenance, or attempted repair by anyone other than Horizon. Return of any goods by Purchaser must be approved in writing by Horizon before shipment.

Damage Limits

HORIZON SHALL NOT BE LIABLE FOR SPECIAL, INDIRECT OR CONSEQUENTIAL DAMAGES, LOSS OF PROFITS OR PRODUCTION OR COMMERCIAL LOSS IN ANY WAY CONNECTED WITH THE PRODUCT, WHETHER SUCH CLAIM IS BASED IN CONTRACT, WARRANTY, NEGLIGENCE, OR STRICT LIABILITY. Further, in no event shall the liability of Horizon exceed the individual price of the Product on which liability is asserted. As Horizon

has no control over use, setup, final assembly, modification or misuse, no liability shall be assumed nor accepted for any resulting damage or injury. By the act of use, setup or assembly, the user accepts all resulting liability.

If you as the Purchaser or user are not prepared to accept the liability associated with the use of this Product, you are advised to return this Product immediately in new and unused condition to the place of purchase.

Law: These Terms are governed by Illinois law (without regard to conflict of law principals).

Safety Precautions

This is a sophisticated hobby Product and not a toy. It must be operated with caution and common sense and requires some basic mechanical ability. Failure to operate this Product in a safe and responsible manner could result in injury or damage to the Product or other property. This Product is not intended for use by children without direct adult supervision. The Product manual contains instructions for safety, operation and maintenance. It is essential to read and follow all the instructions and warnings in the manual, prior to assembly, setup or use, in order to operate correctly and avoid damage or injury.

Questions, Assistance, and Repairs

Your local hobby store and/or place of purchase cannot provide warranty support or repair. Once assembly, setup or use of the Product has been started, you must contact Horizon directly. This will enable Horizon to better answer your questions and service you in the event that you may need any assistance. For questions or assistance, please direct your email to productsupport@horizonhobby.com, or call 877.504.0233 toll free to speak to a Product Support representative.

Inspection or Repairs

If this Product needs to be inspected or repaired, please call for a Return Merchandise Authorization (RMA). Pack the Product securely using a shipping carton. Please note that original boxes may be included, but are not designed to withstand the rigors of shipping without additional protection. Ship via a carrier that provides tracking and insurance for lost or damaged parcels, as Horizon is not responsible for merchandise until it arrives and is accepted at our facility. A Service Repair Request is available at www.horizonhobby.com on the "Support" tab. If you do not have internet access, please include a letter with your complete name, street address, email address and phone number where you can be reached during business days, your RMA number, a list of the included items, method of payment for any non-warranty expenses and a brief summary of the problem. Your original sales receipt must also be

included for warranty consideration. Be sure your name, address, and RMA number are clearly written on the outside of the shipping carton.

Warranty Inspection and Repairs

To receive warranty service, you must include your original sales receipt verifying the proof-of-purchase date. Provided warranty conditions have been met, your Product will be repaired or replaced free of charge. Repair or replacement decisions are at the sole discretion of Horizon Hobby.

Non-Warranty Repairs

Should your repair not be covered by warranty the repair will be completed and payment will be required without notification or estimate of the expense unless the expense exceeds 50% of the retail purchase cost. By submitting the item for repair you are agreeing to payment of the repair without notification. Repair estimates are available upon request. You must include this request with your repair. Non-warranty repair estimates will be billed a minimum of ½ hour of labor. In addition you will be billed for return freight. Please advise us of your preferred method of payment. Horizon accepts money orders and cashiers checks, as well as Visa, MasterCard, American Express, and Discover cards. If you choose to pay by credit card, please include your credit card number and expiration date. Any repair left unpaid or unclaimed after 90 days will be considered abandoned and will be disposed of accordingly. Please note: non-warranty repair is only available on electronics and model engines.

United States:

Electronics and engines requiring inspection or repair should be shipped to the following address:

Horizon Service Center
4105 Fieldstone Road
Champaign, Illinois 61822
USA

All other Products requiring warranty inspection or repair should be shipped to the following address:

Horizon Product Support
4105 Fieldstone Road
Champaign, Illinois 61822
USA

Please call 877-504-0233 or e-mail us at productsupport@horizonhobby.com with any questions or concerns regarding this product or warranty.

United Kingdom:

Electronics and engines requiring inspection or repair should be shipped to the following address:

Horizon Hobby UK
Units 1-4 Ployters Rd
Staple Tye
Harlow, Essex
CM18 7NS
United Kingdom

Please call +44 (0) 1279 641 097 or e-mail us at sales@horizonhobby.co.uk with any questions or concerns regarding this product or warranty.

Germany:

Electronics and engines requiring inspection or repair should be shipped to the following address:

Horizon Technischer Service
Hamburger Strasse 10
25335 Elmshorn
Germany

Please call +49 4121 46199 66 or e-mail us at service@horizonhobby.de with any questions or concerns regarding this product or warranty.

Compliance Information for the European Union



Instructions for Disposal of WEEE by Users in the European Union

This product must not be disposed of with other waste. Instead, it is the user's responsibility to dispose of their waste equipment by handing it over to a designated collection point for the recycling of waste electrical and electronic equipment. The separate collection and recycling of your waste equipment at the time of disposal will help to conserve natural resources and ensure that it is recycled in a manner that protects human health and the environment. For more information about where you can drop off your waste equipment for recycling, please contact your local city office, your household waste disposal service or where you purchased the product.



Declaration of Conformity

(in accordance with ISO/IEC 17050-1)

No. HH2009121001

Product(s): PKZ J-3 Cub Ultra-Micro RTF
Item Number(s): PKZ3900
Equipment class: 1

The objects of declaration described above are in conformity with the requirements of the specifications listed below, following the provisions of the European R&TTE directive 1999/5/EC:

EN 300-328

Technical requirements for Radio equipment.

EN 301 489-1, 301 489-17 General EMC requirements for Radio equipment

EN 60950

Safety

Signed for and on behalf of:
Horizon Hobby, Inc.
Champaign, IL USA
Dec 10, 2009

Steven A. Hall
Vice President
International Operations and Risk
Management
Horizon Hobby, Inc.

Declaration of Conformity

(in accordance with ISO/IEC 17050-1)

No. HH2009121002

Product(s): PKZ J-3 Cub Ultra-Micro BNF
Item Number(s): PKZ3980
Equipment class: 1

The objects of declaration described above are in conformity with the requirements of the specifications listed below, following the provisions of the European R&TTE directive 1999/5/EC:

EN301 489-1, 301 489-17 General EMC requirements for Radio equipment

Signed for and on behalf of:
Horizon Hobby, Inc.
Champaign, IL USA
Dec 10, 2009

Steven A. Hall
Vice President
International Operations and Risk
Management
Horizon Hobby, Inc.