

# F-4 Phantom 32 DF

Assembly Manual



\* Pilot figures shown are not included

**E-flite**<sup>®</sup>  
ADVANCING ELECTRIC FLIGHT

## Notice

All instructions, warranties and other collateral documents are subject to change at the sole discretion of Horizon Hobby, Inc. For up-to-date product literature, visit <http://www.horizonhobby.com> and click on the support tab for this product.

## Meaning of Special Language

The following terms are used throughout the product literature to indicate various levels of potential harm when operating this product:

**NOTICE:** Procedures, which if not properly followed, create a possibility of physical property damage AND a little or no possibility of injury.

**CAUTION:** Procedures, which if not properly followed, create the probability of physical property damage AND a possibility of serious injury.

**WARNING:** Procedures, which if not properly followed, create the probability of property damage, collateral damage, and serious injury OR create a high probability of superficial injury.



**WARNING:** Read the ENTIRE instruction manual to become familiar with the features of the product before operating. Failure to operate the product correctly can result in damage to the product, personal property and cause serious injury.

This is a sophisticated hobby product and NOT a toy. It must be operated with caution and common sense and requires some basic mechanical ability. Failure to operate this Product in a safe and responsible manner could result in injury or damage to the product or other property. This product is not intended for use by children without direct adult supervision. Do not attempt disassembly, use with incompatible components or augment product in any way without the approval of Horizon Hobby, Inc. This manual contains instructions for safety, operation and maintenance. It is essential to read and follow all the instructions and warnings in the manual, prior to assembly, setup or use, in order to operate correctly and avoid damage or serious injury.



## Warnings

Read and follow all instructions and safety precautions before use. Improper use can result in fire, serious injury and damage to property.

**Age Recommendation:**  
**For advanced fliers ages 14 and above.**  
**This is not a toy.**

## COMPONENTS

Use only with compatible components. Should any compatibility questions exist, please refer to the product instructions, the component instructions or contact Horizon Hobby, Inc.

## FLIGHT

Fly only in open areas to ensure safety. It is recommended flying be done at AMA (Academy of Model Aeronautics) approved flying sites. Consult local laws and ordinances before choosing a location to fly your aircraft.

## INTAKE/FAN

Keep loose items that can get entangled in the fan away from the intake and exhaust, including loose clothing or other objects such as pencils and screwdrivers. Especially keep your hands away from the intake and exhaust, as injury can occur.

## BATTERIES

### Notes on Lithium Polymer Batteries

When misused, lithium polymer batteries are significantly more volatile than alkaline or Ni-Cd/ Ni-MH batteries used in RC applications. Always follow the manufacturer's instructions when using and disposing of any batteries. Mishandling of Li-Po batteries can result in fire causing serious injury and damage.

## SMALL PARTS

This kit includes small parts and should not be left unattended near children as choking and serious injury could result.

## SAFETY PRECAUTIONS

- Check all control surfaces prior to each takeoff.
- Do not fly your model near spectators, parking areas or any other area that could result in injury to people or damage of property.
- Do not fly during adverse weather conditions. Poor visibility and/or strong winds can cause disorientation and loss of control of your aircraft.
- Do not take chances. If at any time during flight you observe any erratic or abnormal operation, land immediately and do not resume flight until the cause of the problem has been ascertained and corrected. Safety can never be taken lightly.
- Do not fly near power lines.

## Table of Contents

Introduction .....	3
Important Information Regarding Warranty Information.....	3
Specifications.....	3
Using the Manual.....	3
Contents of Kit/Parts Layout.....	3
Recommended Radio Equipment .....	4
Motor Setup.....	4
Optional Accessories.....	4
Optional Retracts .....	4
Optional Batteries .....	4
UltraCote® Covering Colors .....	4
Hardware/Accessory Sizes.....	4
Required Tools and Adhesives.....	4
Wing Tip Installation .....	5
Hinging the Ailerons and Flaps.....	6
Aileron and Flap Servo Installation.....	7
Control Horn Installation.....	10
Flap and Aileron Linkage Installation.....	11
Wing Spar Installation.....	13
Main Landing Gear Installation .....	15
Optional Main Landing Gear Doors .....	18
Rudder and Elevator Servo Installation.....	21
Rudder Installation .....	22
Elevator Installation .....	24
Fan Installation.....	26
Nose Gear Installation.....	28
Receiver and Speed Control Installation .....	32
Motor Battery Installation .....	33
Canopy Assembly .....	34
Decal Placement.....	35
Center of Gravity .....	36
Control Throws.....	37
Preflight.....	37
Range Test Your Radio .....	38
Flying Your Model .....	38
Daily Flight Checks.....	39
Limited Warranty .....	39
Warranty Services.....	40
Compliance Information for the European Union ....	41
Academy of Model Aeronautics National Model Aircraft Safety Code .....	41

## Introduction

E-flite takes scale ARF ducted fan performance and engineering to new heights with the F-4 Phantom 32 DF. Designed around the E-flite® Delta-V® 32 80mm fan unit and 2150Kv DF32 brushless motor, its bifurcated intake and exhaust, which are engineered for best performance, allow this potent combo to produce large amounts of thrust when powered with an E-flite 6S 5000mAh 30C Li-Po pack. And it does so without resorting to drag-inducing cheater holes. The result is a sport EDF with exhilarating speed that will give even experienced jet jockeys goose bumps. The Platinum Series E-flite® ducted fan F-4 Phantom DF 32 also boasts a level of fit and finish that is every bit as impressive as its performance. Its sleek fiberglass fuselage comes pre-painted and integrates the vertical stabilizer. The fully-sheeted wings are mounted with carbon blade spars and the full flying stabilator is preassembled from the factory to ensure accuracy. And it's covered with genuine UltraCote® covering for the best look and finish. Just add the optional E-flite electric retracts (sold separately), and you've got a scale jet that truly stands out from the crowd.

### Important Information Regarding Warranty Information

Please read our Warranty and Liability Limitations in the back of this manual before building this product. If you as the Purchaser or user are not prepared to accept the liability associated with the use of this Product, you are advised to return this Product immediately in new and unused condition to the place of purchase.

### Specifications

Wingspan:	34.8 in (885mm)
Wing Area:	406 sq in (26.2 sq dm)
Length:	47.2 in (1200mm)
Weight w/o Battery:	5.15–5.45 lb (2.35–2.50 kg)
Weight with Battery:	7.05–7.40 lb (3.20–3.35 kg)

## Using the Manual

This manual is divided into sections to help make assembly easier to understand and to provide breaks between each major section. In addition, check boxes have been placed next to each step to keep track of its completion. Steps with a single circle (○) are performed once, while steps with two or more circles (○○) indicate the step will require repeating, such as for a right or left wing panel, two servos, etc.

Remember to take your time and follow the directions.

### Contents of Kit/Parts Layout

#### Replacement Parts

EFL812501	Fuselage with Hatches
EFL812502	Main Wing Left
EFL812503	Main Wing Right
EFL812504	Horizontal Stabilizer Assembly
EFL812505	Canopy and Engine Hatches
EFL812506	Plastic Accessories
EFL812507	Rudder
EFL812508	Hardware
EFL812509	Pushrods
EFL812510	Decal Sheet
EFL812511	Landing Gear Struts
EFL812512	Tail Cone
EFL812513	Fixed Nose Gear
EFL812514	Foam Main Wheels, 48mm dia
EFL812515	Foam Nose Wheels, 33mm dia

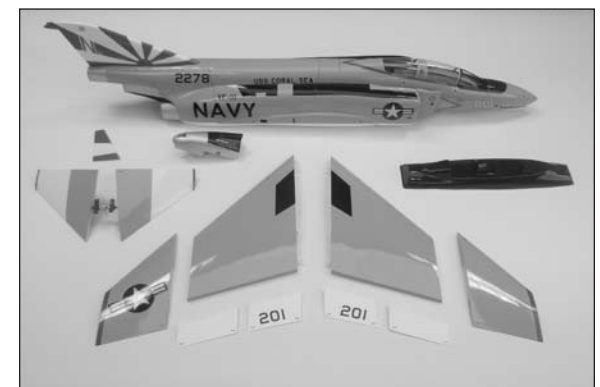

## Recommended Radio Equipment

You will need a minimum 5-channel transmitter, receiver and seven servos.

### Complete Radio System

SPM8800 DX8 DSM2™ 8CH system

### 8-channel receiver installation:

SPMAR8000 AR8000 DSMX 8-Channel Full-Range Receiver  
JSP20030 MC35 Servo (6)  
JRPSDS3421 DS3421 Premium Digital Servo, elevator  
SPMA3058 Y-harness  
SPMA3052 9-inch (228mm) servo extension

➔ The extensions listed for the 8-channel operation (separate ailerons and nose gear) will require the use of mixing at the transmitter.

### 6-channel receiver installation:

SPMAR6210 AR6210 DSMX 6-Channel Full-Range Receiver  
JSP20030 MC35 Servo (6)  
JRPSDS3421 DS3421 Premium Digital Servo, elevator  
SPMA3058 Y-harness (3)  
SPMA3052 9-inch (228mm) servo extension lightweight

➔ The extensions listed for the 6-channel operation will require surfaces (flaps, ailerons and steering-to-rudder) using a Y-harness.

## Motor Setup

EFLM3032DFA DF32 Brushless Motor, 2150Kv  
EFLDF32 Delta-V® 32 80mm EDF  
EFLA1080B 80-Amp Pro SB Brushless ESC v2  
EFLB50006S30 5000mAh 6S 22.2V 30C Li-Po, 10AWG EC5

## Optional Accessories

EFLC3025 Celectra™ 80W AC/DC Multi-Chemistry Battery Charger  
EFLA110 Power Meter  
EFLAEC512 EC5™ Device Charge Lead with 6-inch Wire and Jacks, 12AWG  
PKZ7003 Pilot (2)

## Optional Retracts

EFLG230 15–25 Tricycle Electric Retracts  
SPMA3000 3-inch (76mm) Servo Extension (2)  
SPMA3004 18-inch (457mm) servo extension

## Optional Batteries

EFLB50006S50 5000mAh 6S 22.2V 50C Li-Po, 10AWG EC5  
THP50006SPP65 5000mAh 6-Cell/6S 22.2V G64 Pro Power 65C Li-Po

## UltraCote® Covering Colors

Light Gray HANU882  
True Red HANU866  
Silver HANU881  
White HANU870

## Hardware/Accessory Sizes

Main wheel diameter 1<sup>7</sup>/<sub>8</sub>-inch (48mm)  
Nose wheel diameter 1<sup>5</sup>/<sub>16</sub>-inch (33mm)  
Wing bolt 8-32 x 1/4-inch

## Required Tools and Adhesives

### Tools & Equipment

Balancing stand	Ball driver: 9/64-inch
Flexible tape	Clear tape
Drill	Coarse grit sandpaper
Epoxy brush	Felt-tipped pen
Hobby scissors	Low-tack tape
Mixing cup	Mixing stick
Needle-nose pliers	Paper towels
Pencil	Petroleum jelly
Pin vise	Razor saw
Rotary tool	Rubbing alcohol
Ruler	Sanding block
Sanding drum	Scissors
Side cutter	String
Tie-wraps	Toothpick
Trim seal tool	Two-sided tape
Flat file	
Drill bit: 1/16-inch (1.5mm), 5/64-inch (2mm)	
Hex wrench: 1.5mm, 2.5mm	
Hobby knife with #11 blade	
Medium grit sandpaper	
Phillips screwdriver: #0, #1	

### Adhesives

5-minute epoxy	PAAPT38
15-minute epoxy	MEUEPX15MIN
CA accelerator	PAAPT715
Canopy glue	PAAPT56
Thin CA	PAAPT08
Threadlock	PAAPT42
Silicone adhesive	DEVS250

## ***E-tips***

During the course of building your model, we suggest you use a soft base for the building surface.

Such things as a foam stand, large piece of bedding foam or a thick bath towel will work well and help protect the model from damage during assembly. This is not shown in the instructions to provide the greatest detail in the photos.

## ***E-tips***

When referencing directions (up, down, left, right top and bottom), these directions are in relationship to the pilot sitting in the cockpit of the aircraft unless noted otherwise.

## ***E-tips***

Before starting the assembly of your model, we recommend preparing your radio system for installation. This includes charging the transmitter and receiver batteries, as well as centering the trims and sticks on your transmitter. If using a computer radio, make sure to reset a model memory and name it for this particular model. We also recommend binding the transmitter and receiver at this time following the instructions provided with your radio system.

→ We highly recommend re-binding the radio system once all the control throws are set. This will keep the servos from moving to their endpoints until the transmitter and receiver connect.

## ***Wing Tip Installation***

### **Required Parts**

Main wing panel (right and left)  
Wing tip (right and left)  
3mm x 40mm hardwood dowel (4)

### **Required Tools and Adhesives**

Felt-tipped pen	5-minute epoxy
Mixing stick	Mixing cup
Low-tack tape	Rubbing alcohol
Paper towels	Hobby knife with #11 blade

1. Insert the two 3mm x 40mm hardwood dowels into the wing tip panel.



2. Fit the tip panel to the main panel. Use a felt-tipped pen to trace the outline of the main wing panel on the tip panel.



3. Remove the tip panel and dowels. Use a hobby knife and #11 blade to remove the covering 1/32-inch (1mm) inside the line drawn. Use a paper towel and rubbing alcohol to remove the pen lines.

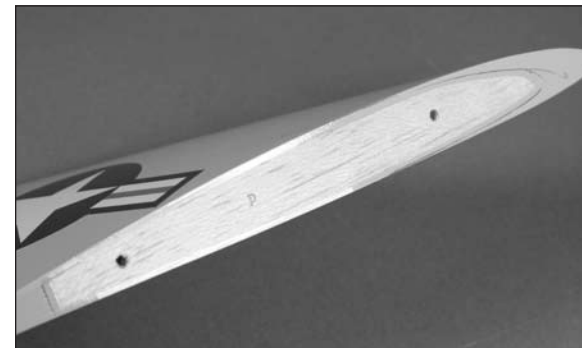

4. Use 5-minute epoxy to glue the two 3mm x 40mm hardwood dowels into the wing tip panel. Use a paper towel and rubbing alcohol to remove any excess epoxy. Allow the epoxy to fully cure before proceeding.

5. Apply a thin coat of 5-minute epoxy to the exposed wood of the main wing panel and the wing tip panel, as well as to the wood dowels. Fit them together and use low-tack tape to hold them together until the epoxy fully cures. Remove any excess epoxy using a paper towel and rubbing alcohol.

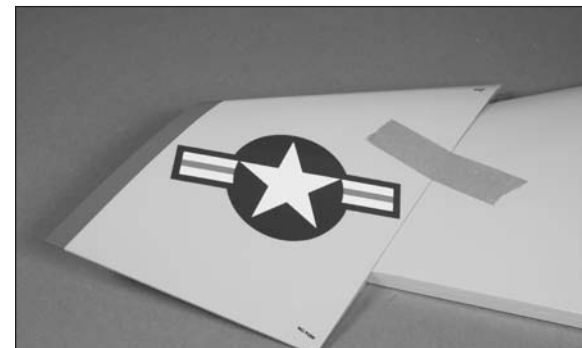

6. Repeat steps 1 through 5 to install the remaining wing tip panel to the main wing panel.

## Hinging the Ailerons and Flaps

### Required Parts

Wing panel (left and right)  
Aileron (left and right)  
Flap (left and right) CA hinge (8)

### Required Tools and Adhesives

Thin CA                      T-pins  
Pin vise                      Drill bit: 1/16-inch (1.5mm)

→ Please follow the procedure for hinging the ailerons and flaps as described in this manual. Failure to correctly hinge these surfaces could result in the surface becoming loose in flight, resulting in the loss of your aircraft.

- ○ 1. Use a pin vise and 1/16-inch (1.5mm) drill bit to drill a hole in the center of each hinge slot in the ailerons, flaps and wing panels. This will provide a tunnel for the CA to wick into, making the bond between the hinge and wood stronger.

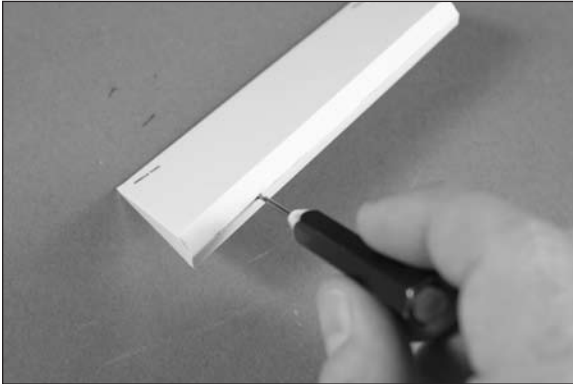

- ○ 2. Slide the hinges into the aileron and flap. Insert the hinges so the holes in the hinge are at the hinge line. Insert a T-pin through one of the holes to keep the hinge centered while the aileron and flap are installed on the wing panel.

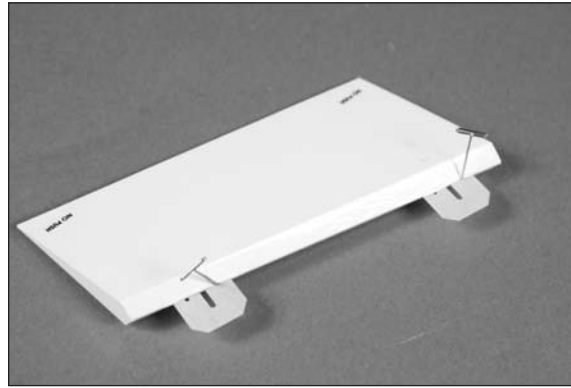

- ○ 3. Slide the hinges in the aileron into the slots on the wing. Note the orientation of the ailerons and flaps. They will only fit correctly one way with all decals showing on the top. Leave a small gap at the wing tip. Install the flap making sure the aileron and flap can move without interference. Also make sure the flap is set in an equal distance from a line projected from the root of the wing to prevent it from rubbing against the fuselage. The gap between each surface, and the line projected from the wing root, should be equal.

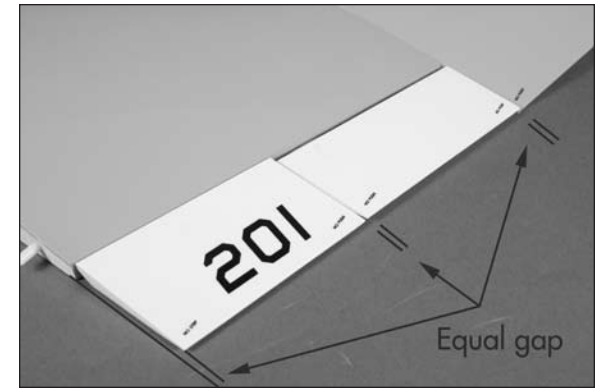
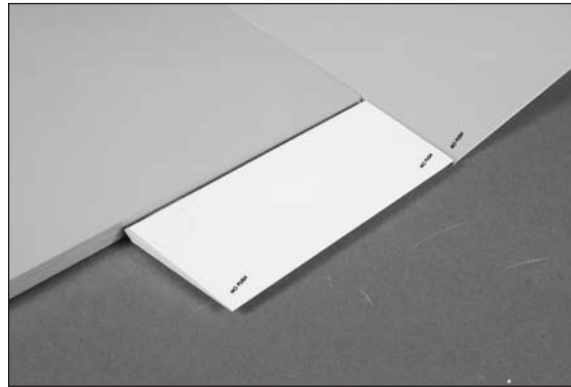

***Etips***

When gluing the hinges, do not use a CA accelerator. The CA must be allowed time to soak into the hinges to provide the best bond between the hinge and surrounding wood.

- ○ 4. Remove the T-pins from the hinges. Make sure the aileron and flap are tight against the wing. Wick thin CA into each hinge, both top and bottom, until the hinge is saturated with CA. Allow the CA to fully cure before proceeding.



- 5. Once the CA has fully cured, gently pull on the wing and aileron (and flap) to make sure the hinges are glued securely. If not, reapply thin CA to any hinges that are not secure. Flex the aileron and flap through their range of motion a number of times to break in the hinges. This will reduce the initial load on the servo for your first flights.

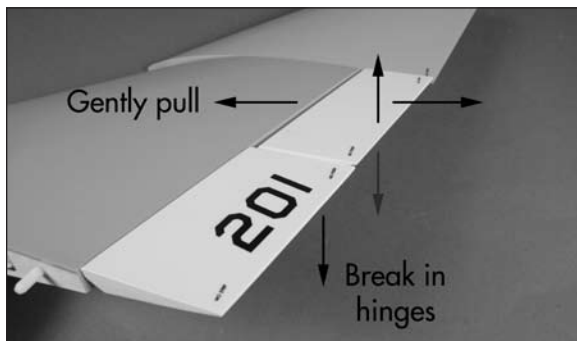

- 6. Repeat Steps 1 through 5 to install the remaining aileron and flap hinges.

## Aileron and Flap Servo Installation

### Required Parts

Wing panel (right and left)  
 Transmitter                      Receiver  
 Receiver battery  
 Servo with hardware (4)  
 Hardwood block, 15mm x 13mm x 6mm (8)  
 2mm x 8mm self-tapping screw (16)

### Required Tools and Adhesives

Phillips screwdriver: #1  
 Hobby knife with #11 blade  
 Pencil                                  Razor saw  
 Thin CA                                5-minute epoxy  
 Mixing cup                            Mixing stick  
 Drill                                      Drill bit: 5/64-inch (2mm)  
 Side cutter                            Pin vise  
 Felt-tipped pen                      Medium grit sandpaper

**E-tips**

When centering the flap servo, begin by setting the throws at the transmitter to 0% for both the up and down flap positions. This should be done for both 2- and 3-position flap switches.

- 1. Prepare the aileron and flap servos by installing the rubber grommets and brass eyelets as shown in the radio or servo instructions. Use the shorter side of a JR standard horn for the two aileron servos and the longer side for the flap servos. Center the aileron and flap servos using the radio system. Use side cutters to remove any arms from the horn that may interfere with the operation of the servo. Note that one servo is set in the opposite orientation as shown in the photo in the following column.

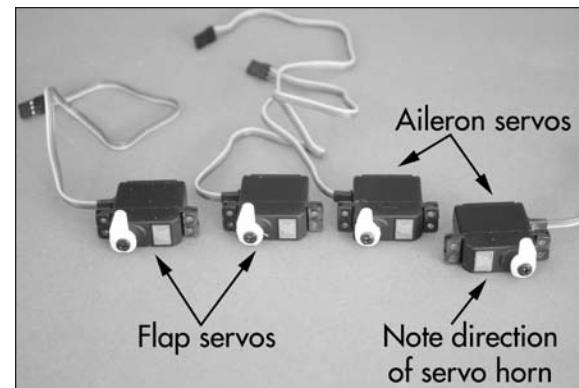

- 2. Use a felt-tipped pen to mark the flap and aileron servo covers so they can be returned to their correct locations, then remove the covers from the wing. Set the flap cover aside. Use a pencil to mark the centerlines for the servo output on the cover. Position the servo on the cover so the center of the servo horn is centered in the opening using the lines drawn on the cover. Use a pencil to mark the locations for the servo mounting blocks on the servo cover.

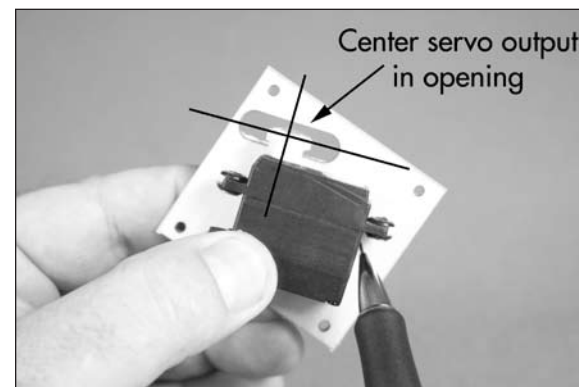

- 3. Sand the 6mm x 13mm end of the four hardwood blocks using medium grit sandpaper to provide a surface for the glue to adhere to. This will be the end glued to the plate in the following step.



- 4. Use 5-minute epoxy to glue the blocks to the cover in alignment with the marks you made. Allow the epoxy to fully cure before proceeding.

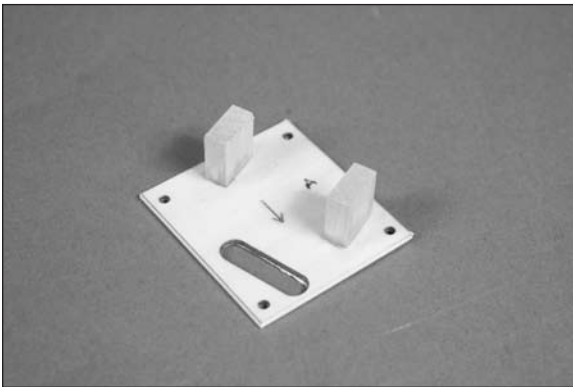

- 5. Position the servo on the blocks. Use a pencil to mark the block for the servo lead. Use a razor saw to trim the block to provide clearance for the servo lead.

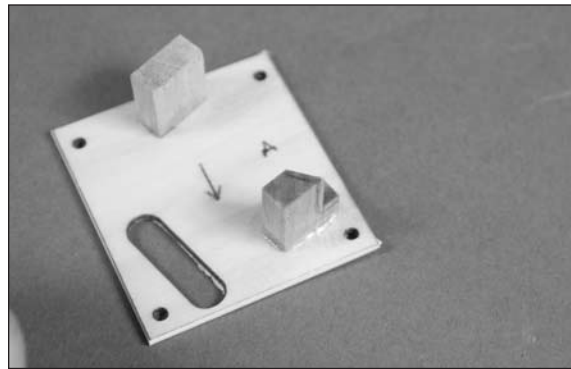
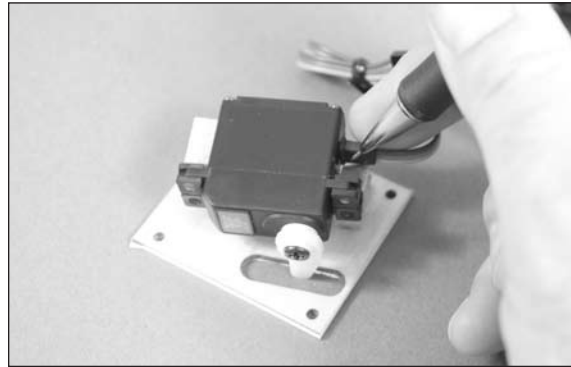

- 6. Position the servo between the two blocks. With the servo resting against the servo cover, use a pencil to mark the locations for the four servo mounting screws on the blocks.

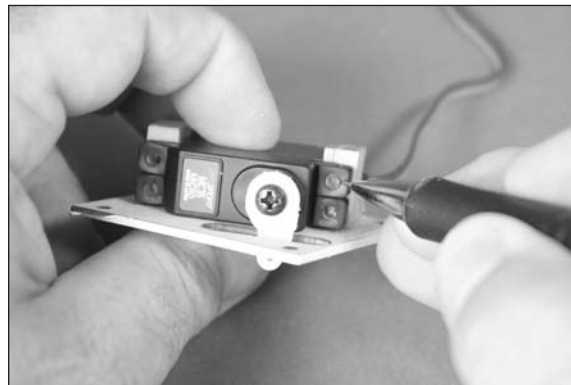

- 7. Use a drill and 5/64-inch (2mm) drill bit to drill the holes for the mounting screws. Use care not to enlarge the holes any larger than the drill bit.

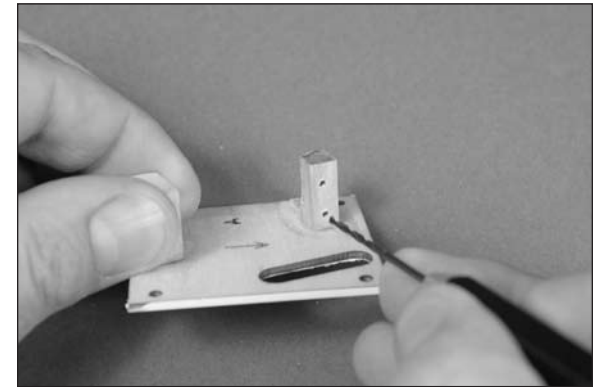

- 8. Use a #1 Phillips screwdriver to thread a servo mounting screw into each of the holes. Remove the screw then apply 2–3 drops of thin CA in each hole and saturate the front and rear of the block to harden the hardwood block. This will help keep the blocks from splitting when the servo mounting screws are installed.

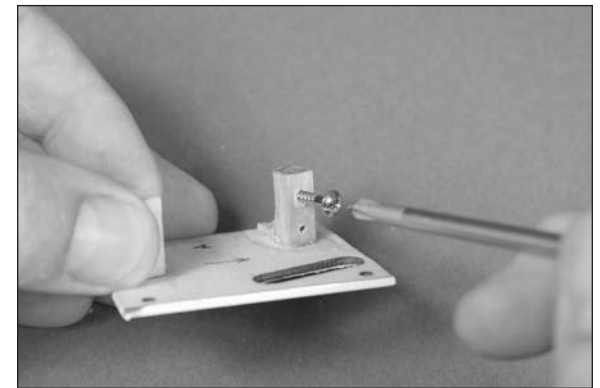



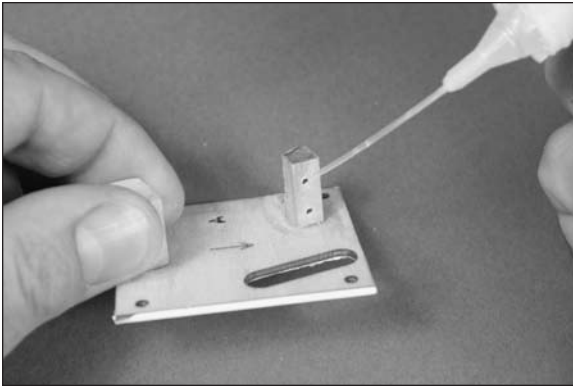

## ***Etips***

Do not use a CA accelerator. Using an accelerator will not allow the CA to soak into the fibers of the wood, hardening the hardwood block.

- 9. Sand the top of the blocks so they are flush with the top of the servo. Also trim or sand the edge of the block so that it does not interfere with the mounting rim of the wing hole. The blocks may be a very close fit, and may just hit the mounting rim on the cover. This is dependant on the exact location of the servo. Use the screws provided with the servo and a #1 Phillips screwdriver to attach the servo to the mounting blocks.

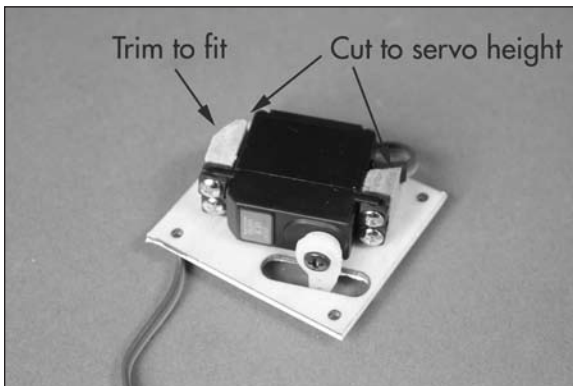

- 10. Use a #1 Phillips screwdriver to thread a 2mm x 8mm self-tapping screw into each of the servo cover mounting holes. This will cut threads in the surrounding wood. Remove the screw then apply 2-3 drops of thin CA in each hole to harden the wood.

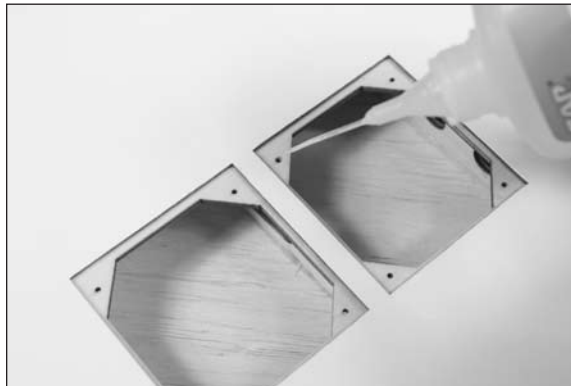
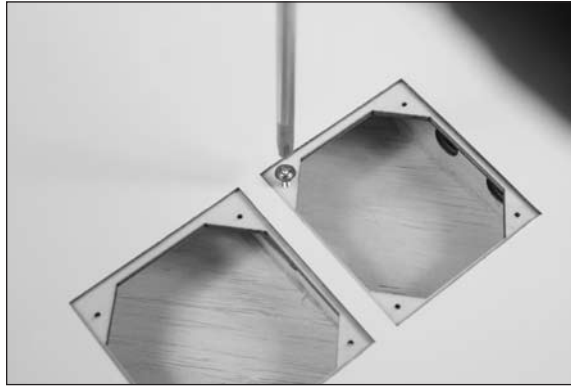

- 11. Tie the end of the string around the end of the aileron servo lead. Use the string to pull the leads through the wing and out at the root rib as shown.

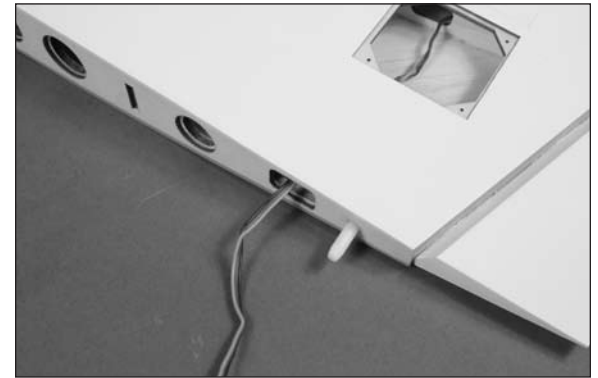

- 12. Use four 2mm x 8mm self-tapping screws and a #1 Phillips screwdriver to secure the aileron servo cover to the wing.

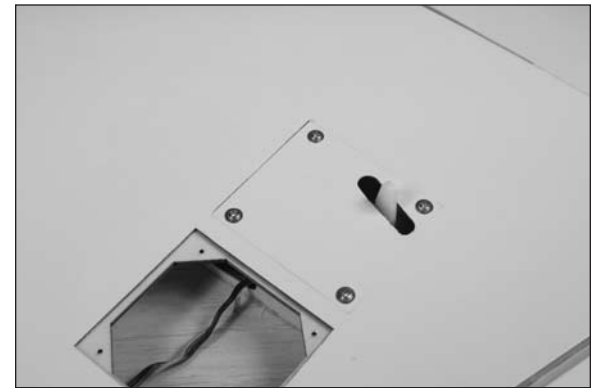

- ○ ○ ○ 13. Pass the flap servo lead through the same hole in the wing root as the aileron servo. Use four 2mm x 8mm self-tapping screws and a #1 Phillips screwdriver to secure the flap servo cover to the wing.



- 14. Repeat steps 2 through 13 for the remaining wing panel.



## **Control Horn Installation**

### **Required Parts**

Wing panel (right and left)  
Fiberglass control horn (4)

### **Required Tools and Adhesives**

Felt-tipped pen      5-minute epoxy  
Mixing stick          Mixing cup  
Low-tack tape        Coarse grit sandpaper  
Hobby knife with #11 blade

- 1. Use low-tack tape to tape the aileron at the tip and tape the flap to the aileron so they don't move during the control horn installation.
- ○ ○ ○ 1. Use a hobby knife and #11 blade to remove the covering from the slot for the aileron control horn.

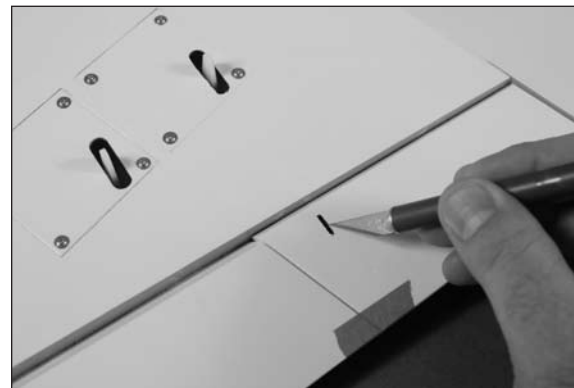

- ○ ○ ○ 2. Check the fit of the fiberglass control horn in the slot in the aileron. The hole in the control horn will align with the hinge line. The horn should fit flush in the hole. Use a felt-tipped pen to mark the front and rear edge of the control horn on the aileron.

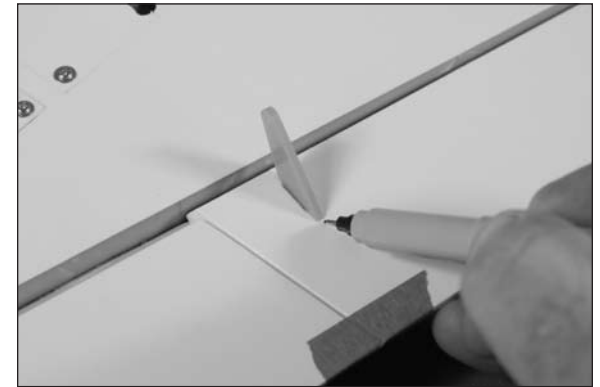

- ○ ○ ○ 3. Apply low-tack tape around the opening for the aileron control horn. Position the tape so it is 1/32-inch (1mm) away from the sides of the hole, as well as from the marks made in the previous step.

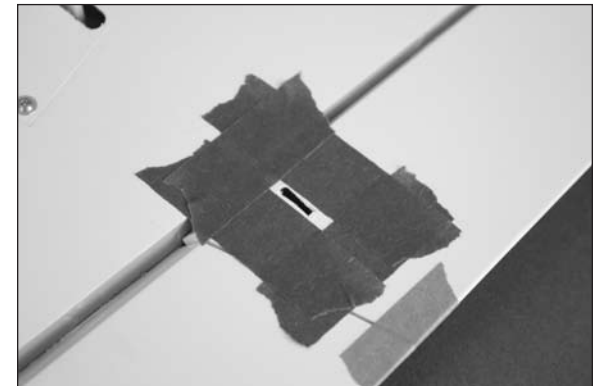

- 4. Use coarse grit sandpaper to lightly sand the control horns where they fit into the openings in the flap and aileron.

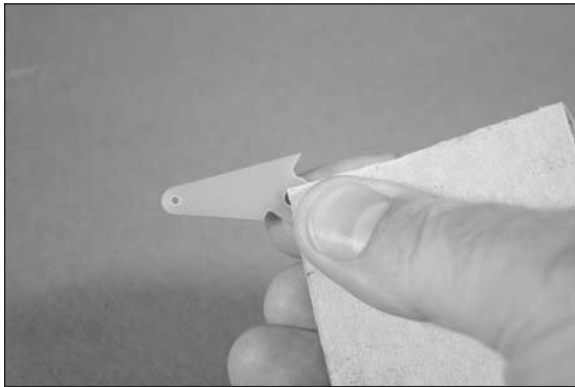

- 5. Repeat Steps 1 through 4 to prepare the remaining aileron and flap control horns.

- 6. Use 5-minute epoxy to glue the control horn into the holes for the aileron. Use a square to make sure the control horn is perpendicular to the control surface. Double-check the hole in the control horn to ensure it is directly over the hinge line.

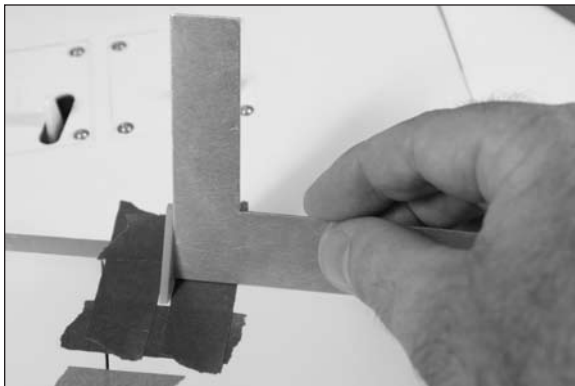

- 7. After around 3 minutes, before the epoxy cures, carefully remove the tape from around the control horns. Pull the tape away from the horn, being careful not to disturb the position of the control horn. This will allow the epoxy to flow out slightly, leaving a fillet between the control horn and control surface.

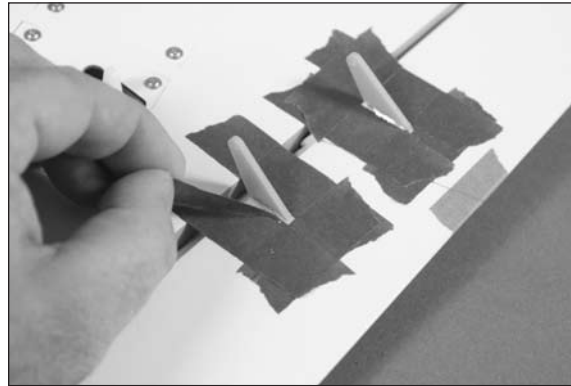

- 8. Repeat Steps 6 and 7 to install the remaining aileron and flap control horn.

## Flap and Aileron Linkage Installation

### Required Parts

Wing panel (right and left)	
Transmitter	Receiver
Receiver battery	Silicone tubing
Metal clevis (8)	2mm nut (6)
Threaded rod, 2mm x 25mm (2)	
Threaded rod, 2mm x 40mm (2)	

### Required Tools and Adhesives

Ruler	Threadlock
Needle-nose pliers	

**E-tips**

Always use threadlock on metal-to-metal fasteners to prevent them from vibrating loose.

- 1. Use a hobby knife to cut four 1/4-inch (6mm) pieces of silicone tubing. Assemble the aileron linkage using the silicone tubing, two 2mm nuts, two metal clevises, and a 2mm x 25mm threaded rod. Assemble the flap linkage using the silicone tubing, one 2mm nut, two metal clevises, and a 2mm x 25mm threaded rod. Use the length in the photo as a starting point for the length of the rod.

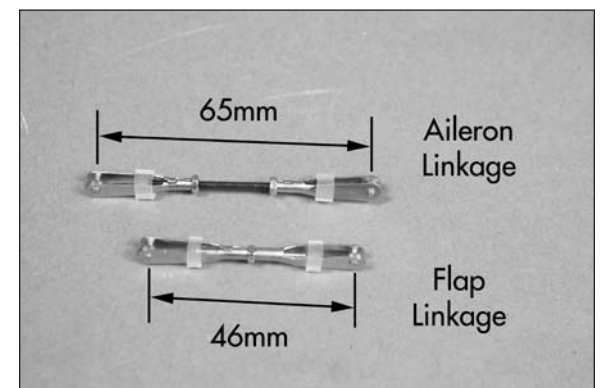

- ○ 2. Connect the aileron linkage to the hole in the servo horn 7/16-inch (11mm) from the center of the servo arm, and connect the flap linkage to the hole in the servo horn 1/2-inch (13mm) from the center of the arm.
- ○ 3. Remove the tape holding the flap and aileron in position. Connect one clevis of the longer pushrod to the outer hole of the aileron servo horn. The remaining clevis connects to the aileron control horn. Adjust the length of the linkage so the aileron is centered when the servo is centered. Connect one clevis of the shorter pushrod to the outer hole of the flap servo arm and the other end to the flap control horn. Adjust the length of the flap linkage so when the flap servo is centered, the flap is positioned as shown. Once the length of the linkages has been adjusted, slide the tubing over the forks of the clevises to keep them from accidentally opening in flight. Use needle nose pliers to tighten the nuts against the metal clevises.

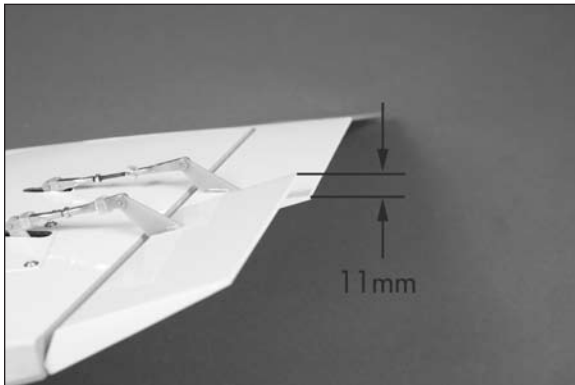

- ○ 4. Set the switch at the transmitter to the UP flap position. Adjust the flap system values of the transmitter for the up position until the flap is aligned with the aileron. This will be the UP flap position.

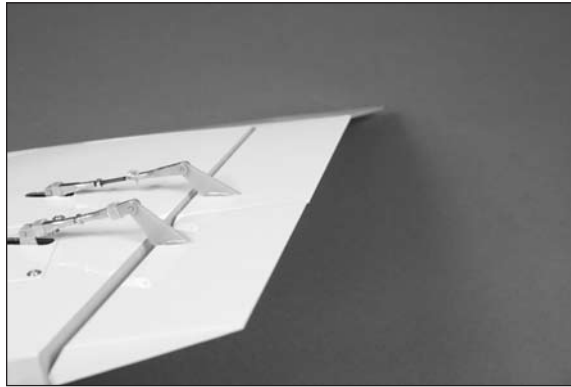

- ○ 5. Set the switch at the transmitter to the DOWN flap position. Adjust the ATV at the transmitter for the down position until the flap is 30mm below the aileron. This will be the DOWN flap position.

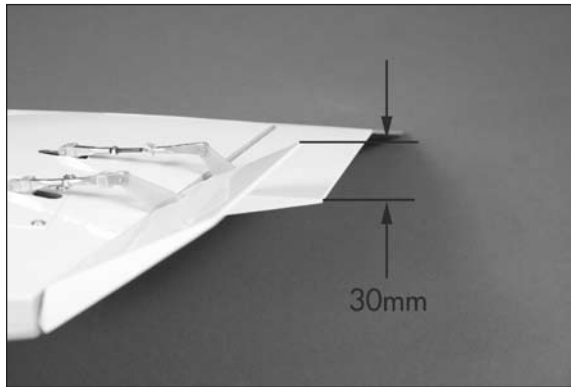

### ***E-tips***

Because there can be minor differences in control horn and servo positions, do not connect the linkage as described in steps 2 to the opposite flap until you have checked the throws. Doing so may cause the servo to bind in the UP position, which could cause damage to the flap servo.

- 6. Repeat steps 2 through 5 to prepare and install the remaining flap and aileron linkages. Before connecting the flap linkage, set the flap switch to the UP flap position. Connect the linkage to the flap servo and adjust its length until the flap is aligned with the aileron. This will be the UP flap position.

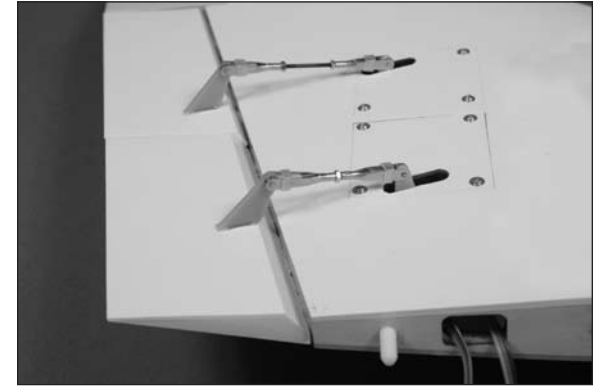

### ***E-tips***

You may have to fine-tune both flap linkages up or down so they align at all three positions: up, middle, and down. It is very important to use servo arms positioned at the same angle on the splines of the servo so the travel will match in all positions.

## Wing Spar Installation

### Required Parts

Fuselage Carbon wing spar (2)  
8-32 x 1/4-inch socket head screw (4)  
Wing panel assembly (right and left)

### Required Tools and Adhesives

Low-tack tape  
15-minute epoxy Mixing cup  
Paper towels Mixing stick  
Epoxy brush Rubbing alcohol  
Ruler Medium grit sandpaper  
Petroleum jelly Felt-tipped pen  
Ball driver: 9/64-inch

- 1. Remove the radio cover and canopy from the fuselage by lifting them up from the base, rather than from the sides, as the magnets are strong to hold them down during high-speed maneuvers. The radio cover is held in place with magnets at the front and a pin in the rear. Set the cover aside so it doesn't get damaged.



- 2. Use a 9/64-inch ball driver to start the four 8-32 x 1/4-inch socket head bolts in the aluminum wing sockets inside the fuselage. Only thread the screws in a few turns at this time. Use care not to cross-thread the screws and damage the threads in the aluminum sockets.

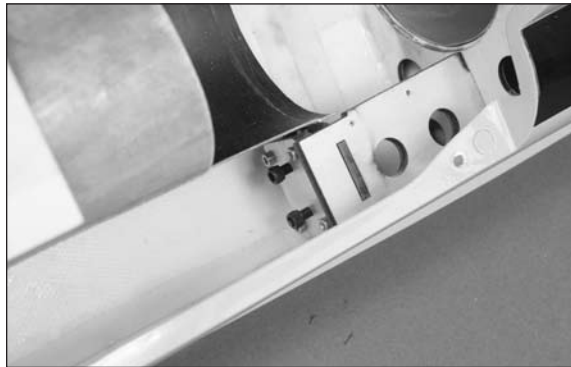

- 3. Locate the carbon wing spar. The spar is symmetrical and has no top or bottom. Slide the carbon wing spar in the spar pocket of the wing, narrow end first. The spar will slide in easily, so don't force it in any further than it will slide. Use a felt-tipped pen to mark the spar at the wing root.

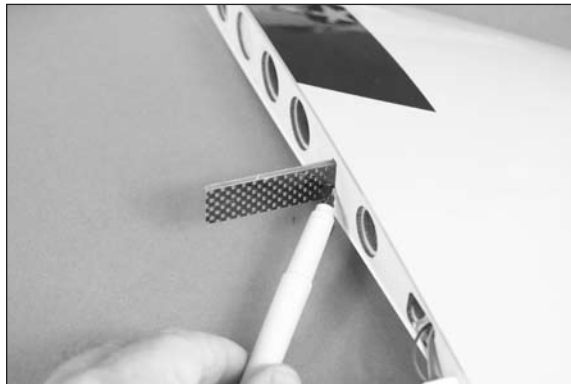

- 4. Remove the spar from the spar pocket. Use medium grit sandpaper to lightly sand the spar where it fits into the wing. Sand both the front and back of the spar.



- 5. Slide the spar into the spar pocket in the fuselage. It will easily slide into the pocket up to the line made in step 3. If not, the screws installed in step 2 may be in the way and require loosening.



- ○ 6. Check the fit of the wing on the fuselage. It must rest tightly against the fuselage. If the spar fits into the wing and fuselage spar pockets without any problems, the fit should be perfect. Make sure to guide the leads for the aileron and flap into the fuselage so they don't interfere with the fit.

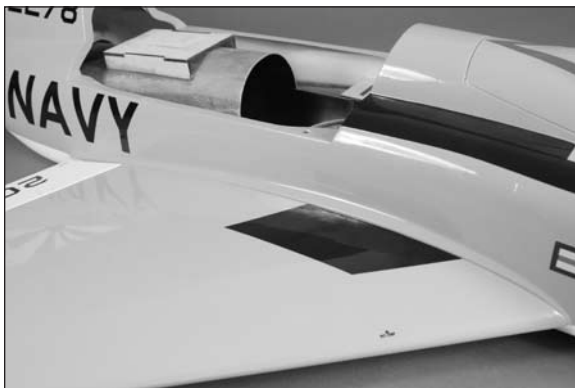

- ○ 7. Remove the wing and spar from the fuselage. Apply a thin coat of petroleum jelly to the fuselage around the wing socket. This will keep you from accidentally gluing the wing to the fuselage during the following procedure.

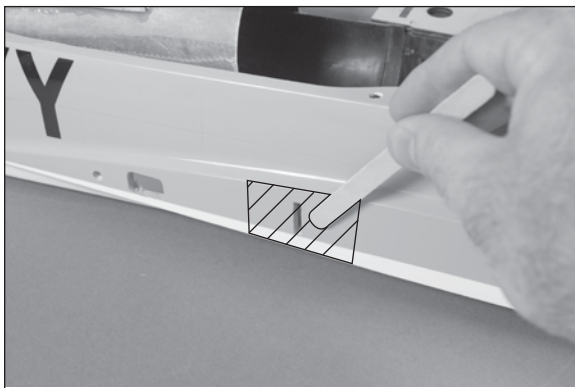

***E-tips***

Before mixing any epoxy, make sure to read through and understand the following steps. It is important to perform these steps before the epoxy fully cures.

- ○ 8. Mix 1/2 ounce (15mL) of 15-minute epoxy. Apply the epoxy to the spar pocket of the wing using a mixing stick.

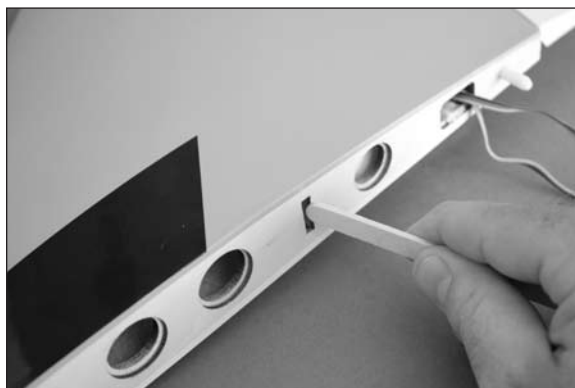

- ○ 9. Use an epoxy brush to apply epoxy to the front, back, top and bottom of the spar where it fits into the wing.

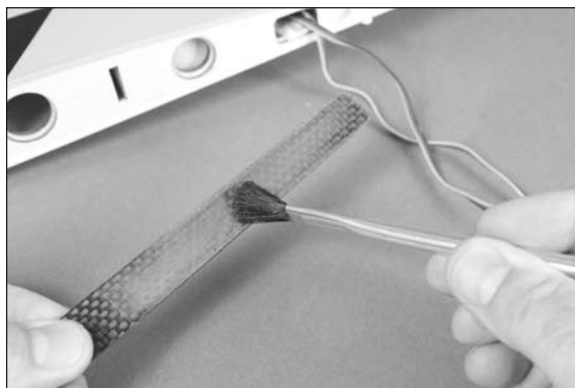

- ○ 10. Slide the spar into the spar pocket of the wing, making sure it is oriented correctly. Use a paper towel and rubbing alcohol to remove any excess epoxy from the wing and spar.

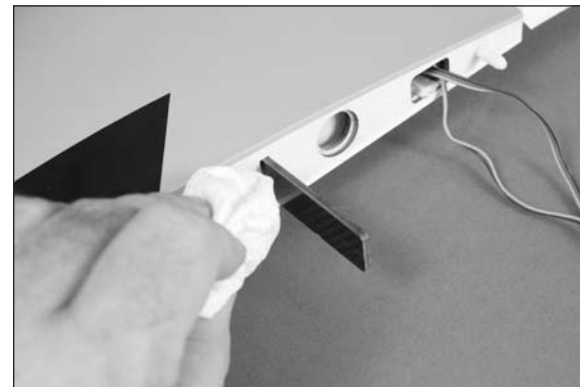

***E-tips***

Epoxy will ooze out from the spar pocket of the wing. If epoxy does not ooze out, not enough epoxy was used to glue the spar into the wing.

- ○ 11. Before the epoxy cures, slide the wing into position against the fuselage. Keep the wing tight against the fuselage until the epoxy fully cures. You can use a 9/64-inch ball driver to lightly tighten the screws to secure the wing joiner in the fuselage, and low-tack tape to hold the wing in position until the epoxy has cured.



- 12. Once the epoxy has cured, remove the wing panel from the fuselage. Repeat steps 3 through 11 to install the remaining wing panel to the fuselage.
- 13. Once the epoxy has fully cured and both wing panels have spars, remove any petroleum jelly residue from the fuselage and wing using rubbing alcohol and a paper towel.

## Main Landing Gear Installation

### Required Parts

Wing panel assembly (right and left)  
 Aluminum wheel collar with setscrew, 3.5mm (2)  
 Aluminum wheel spacer, 3.5mm (2)  
 Wheel, 17/8-inch (48mm) (2)  
 Main landing gear strut (right and left)  
 3mm x 14mm countersunk self-tapping screw (8)

### Required Parts (Fixed Gear Specific)

Main fixed landing gear unit (2)

### Required Parts (Retract Specific)

Transmitter                      Receiver  
 Receiver battery  
 Servo extension, 3-inch (76mm) (2)  
 Main landing gear retract (2)

### Required Tools and Adhesives

Drill                                      Drill bit: 5/64-inch (2mm)  
 Threadlock                              Hex wrench: 1.5mm  
 Thin CA                                      Phillips screwdriver: #1  
 Trim seal tool                              Hobby knife with #11 blade  
 Low-tack tape

➔ The installation of the retracts and fixed gear follow the same procedure. The only difference is the cutting of the covering and the routing of the retract lead, which has been highlighted in gray.

- 1. Use a hobby knife with a new #11 blade to remove the covering to access the landing gear mounts and wheel well if using the retracts. Leave 1/32-inch (1mm) of covering around the inside edges. Use a trim seal tool to iron down the covering around the edges to finish the opening.

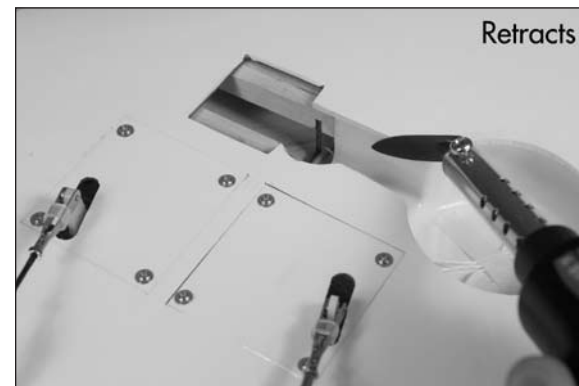

- 2. Place a main landing gear block or retract mechanism in the wing. The landing gear block may distort the covering slightly during its installation when installing the fixed gear. Make sure it is resting flat on the landing gear rails.

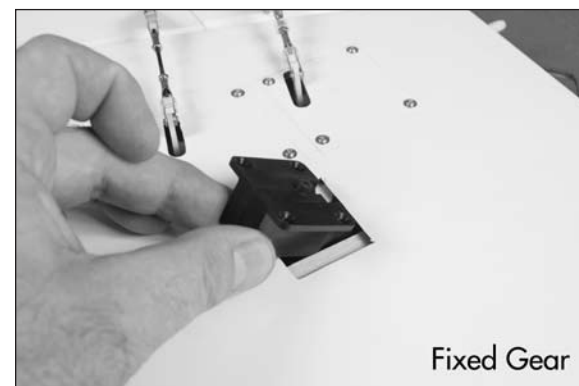

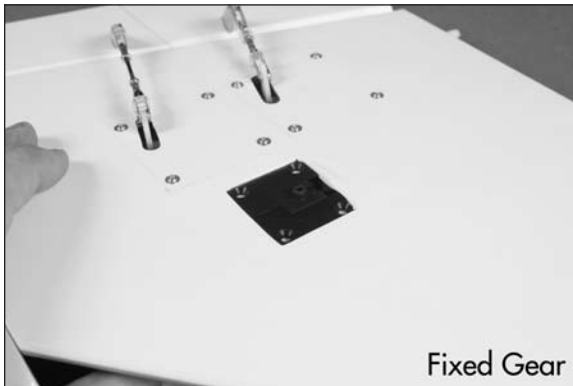
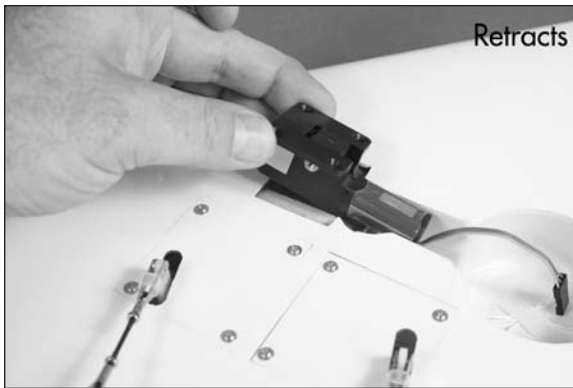

- ○ 3. Prepare a 5/64-inch (2mm) drill bit by wrapping a piece of low-tack tape around the drill bit 5/8-inch (16mm) from the end of the bit. This will act as a marker so you don't accidentally drill through the top of the wing. Place the drill bit in a drill.



- ○ 4. Use the drill and drill bit prepared in the previous step to drill the four holes for the landing gear block or retract mechanism mounting screws.

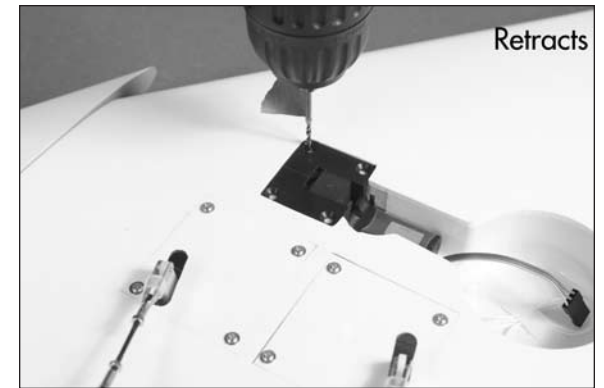
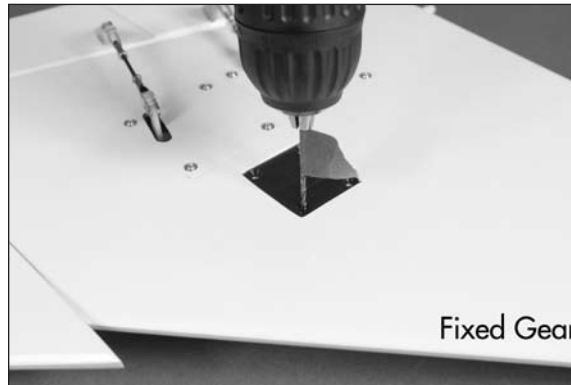

- ○ 5. Remove the landing gear block or retract mechanism from the wing. Use a #1 Phillips screwdriver to thread a 3mm x 14mm countersunk self-tapping screw in each hole to cut threads into the landing gear rails. Remove the screws after threading the holes.

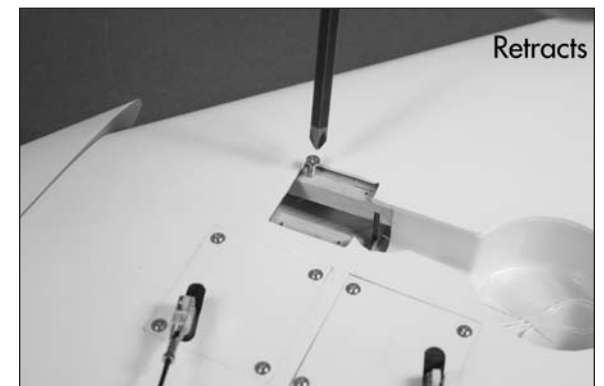
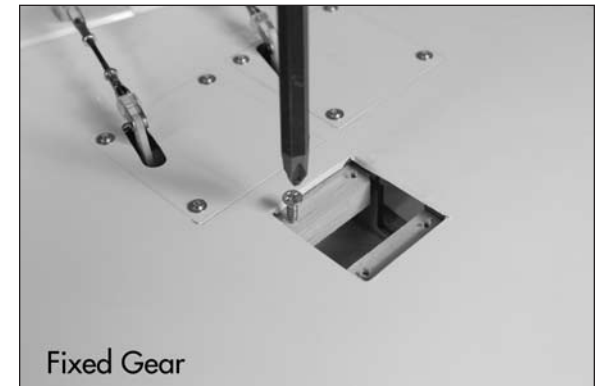



- 6. Place 2-3 drops of thin CA in each of the holes. This will harden the threads made by the screws, making them more secure when the landing gear block or retract mechanism is installed.



Fixed Gear

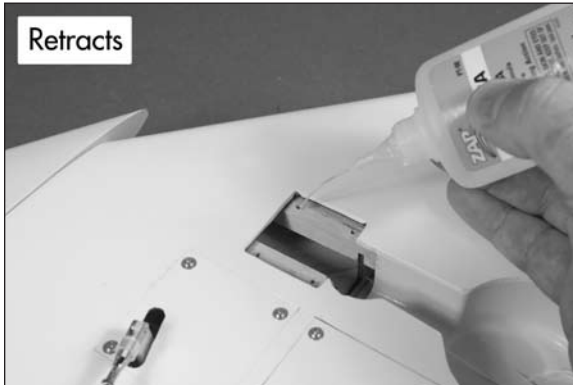

Retracts

## **E-tips**

We have designed the main gear struts to work with both the fixed gear and the suggested retracts. These struts are designed for the weight and speeds of the F-4 Phantom. Use the struts supplied with the kit for the retract assembly.

## **E-tips**

Always use threadlock on metal-to-metal fasteners to prevent them from vibrating loose.

- 7. Slide a main gear strut into the main landing gear block or retract mechanism. Use the setscrews and a 1.5mm hex wrench to secure the main gear wire in the block. The setscrews will tighten down on each of the flat areas at the top of the strut to prevent the strut from rotating in the block. Assemble the right and left main gear assemblies at this time.

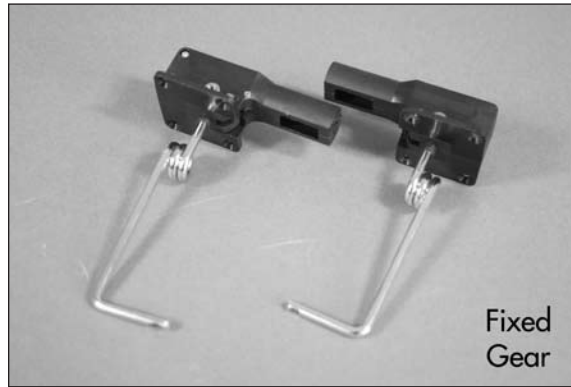

Fixed Gear

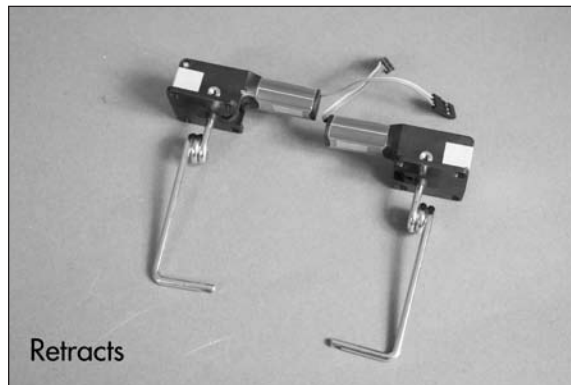

Retracts

- A. Secure a 3-inch (76mm) servo extension to the retract lead using string or dental floss.

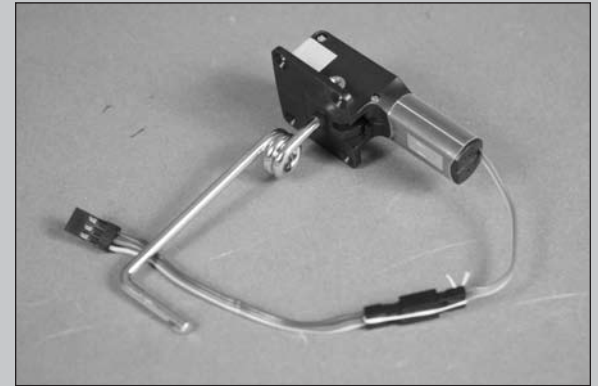

- B. Tie the string to the extension. Use the string to pull the lead through the wing and out along-side of the aileron and flap leads. Mark the retract lead so it can be easily identified.

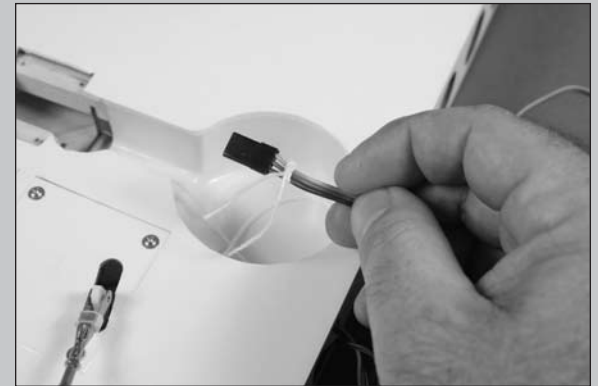

- 8. Place the correct main gear assembly in position. The axle will face to the root of the wing, and the spring will face to the trailing edge of the wing. Use four 3mm x 14mm countersunk self-tapping screws and a #1 Phillips screwdriver to tighten the screws.

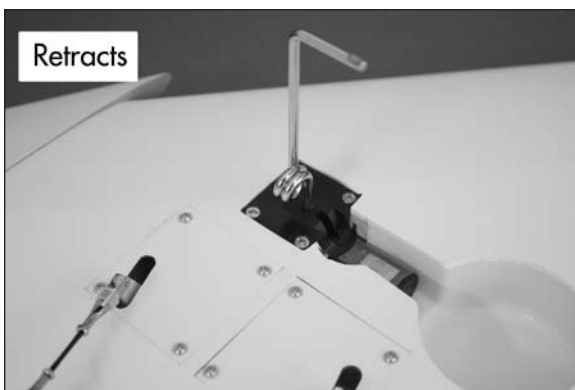

### **E-tips**

The end of the axles may have a slight bur on them from the factory. If the wheel is hard to install, use a file to remove this bur.

### **E-tips**

Always use threadlock on metal-to-metal fasteners to prevent them from vibrating loose.

- 9. Slide a 3.5mm aluminum wheel spacer on the axle, then the wheel. A 3.5mm wheel collar is used to secure the wheel in position by tightening the setscrews onto the axle using a 1.5mm hex wrench.

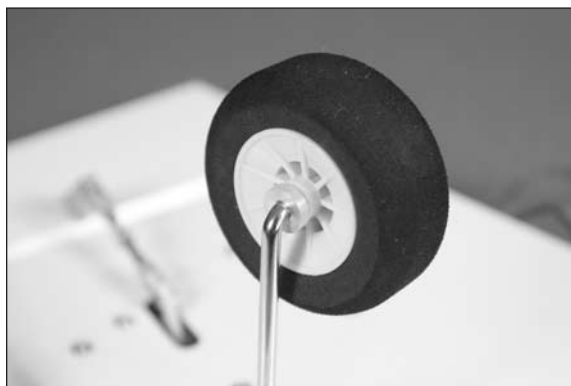

- 10. Repeat steps 2 through 9 to install the remaining main landing gear and wheel.

## **Optional Main Landing Gear Doors**

### **Required Parts**

Wing assembly (right and left)  
 Transmitter Receiver  
 Receiver battery Landing gear door (2)  
 2mm x 8mm self-tapping screw (8)  
 Landing gear door block (4)

### **Required Tools and Adhesives**

Rotary tool Sanding drum  
 Sanding block Medium grit sandpaper  
 Ruler Pencil  
 Pin vise Drill  
 Canopy glue Drill bit: 1/16-inch (1.5mm)  
 Thin CA Side cutter  
 Phillips screwdriver: #0

➔ The installation of the landing gear doors are optional, and they can be installed at any time during the life of your model.

- 1. Use a hobby knife with a #11 blade to separate the two landing gear doors.



- 2. Use a pencil to draw a centerline on the unpainted side of the landing gear door. Draw two lines on the door that are 1-inch (24mm) and 1<sup>3</sup>/<sub>4</sub>-inch (44mm) from the top edge of the landing gear door as the center lines for the mounting blocks.

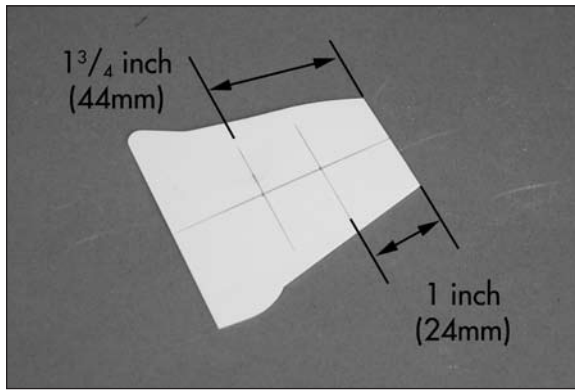

- 3. Use a pin vise and 1/16-inch (1.5mm) drill bit to drill four holes in the landing gear door that are 5/32-inch (4mm) from the centerline along the lines drawn in the previous step.

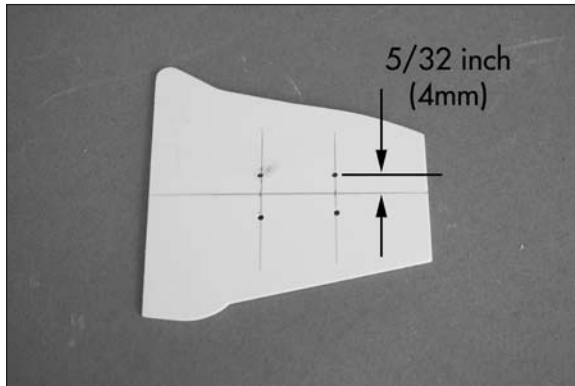

- 4. Use a straight edge or ruler to lightly bend the landing gear door along the center line so it will rest tightly against the wing when the gear are retracted. Work slowly to avoid cracking the paint on the outside of the landing gear door.

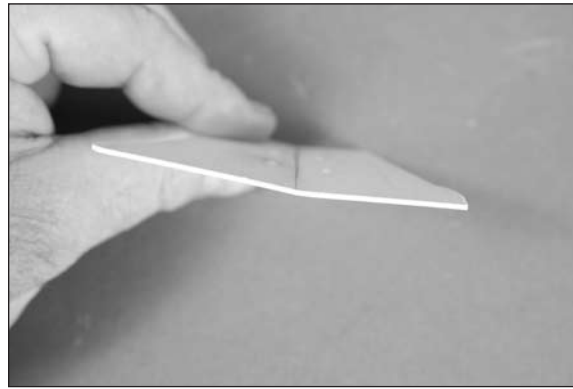

- 5. Locate the landing gear door blocks. Use a sanding block and medium grit sandpaper to sand an angle on the notched side, so the block will rest flat against the angle of the landing gear door. Prepare both blocks at this time.

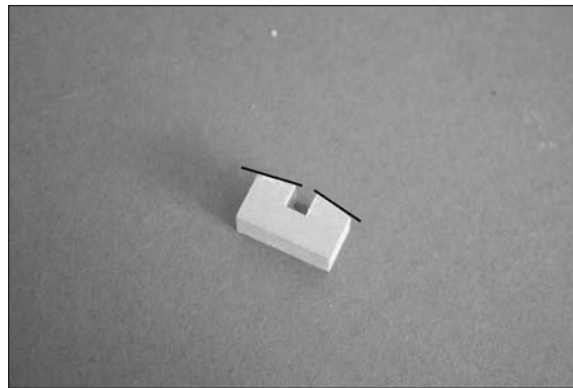

- 6. Rest the landing gear door block on the gear door, centering it on the lines previously drawn. Use a pencil to transfer the mounting holes from the landing gear door onto the block.

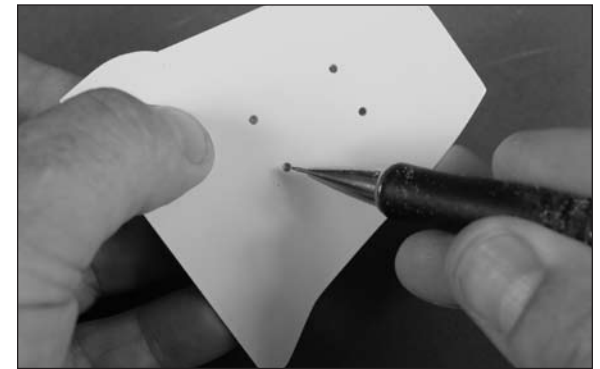
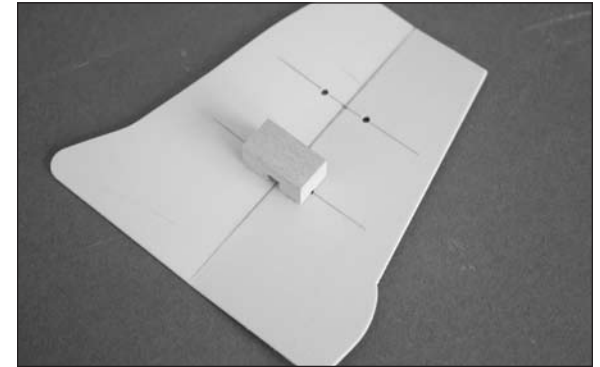

- 7. Use a drill and 1/16-inch (1.5mm) drill bit to drill the two mounting holes in the landing gear door block.

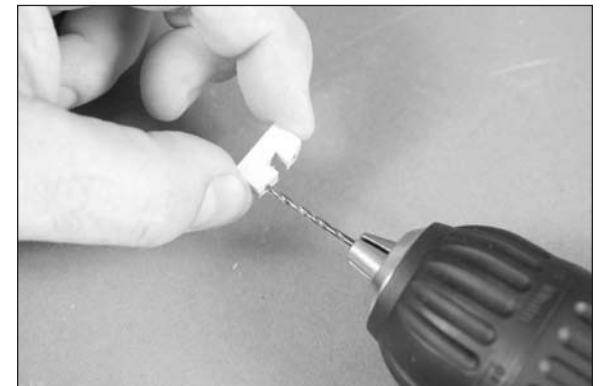

- 8. Use a sanding block and medium grit sandpaper to round the back of the landing gear door block. This will allow the gear to retract into the wing and help center the gear while it is retracting.

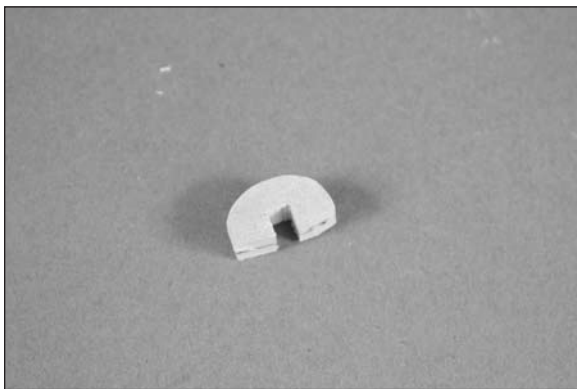

- 9. Use a #0 Phillips screwdriver to install a 2mm x 8mm self-tapping screw in each of the mounting holes in the landing gear door block. Remove the screws after cutting the threads in the blocks. Be careful not to split the blocks as you install the screws for the first time.



- 10. Place 2-3 drops of thin CA in each of the mounting holes. This will harden the threads made by the screws, making them more secure when the landing gear door is installed.

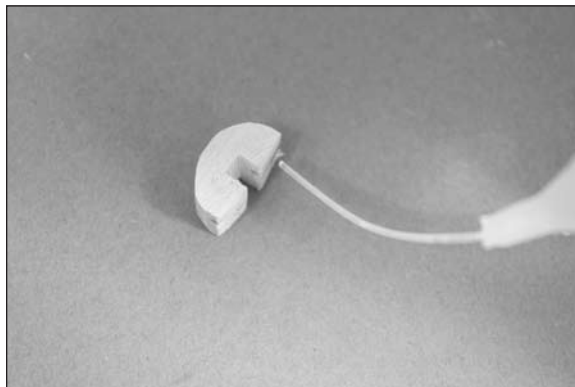

- 11. Repeat steps 7 through 10 to prepare the second landing gear door mounting block.
- 12. Attach the landing gear door to the strut using four 2mm x 8mm self-tapping screws and a #0 Phillips screwdriver.

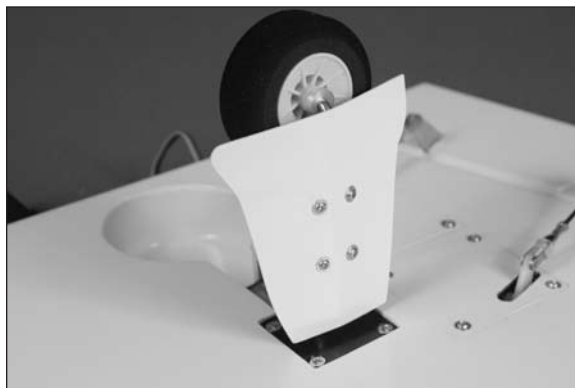

***E-tips***

Work slowly when using a sanding drum on the screws. The screws will heat up while sanding, which could melt the landing gear door.

- 13. Use side cutters and a rotary tool with a sanding drum to smooth the ends of the screws against the inside of the blocks. If this is not done, the screws could catch on the edges of the retract opening and cause the gear to not retract correctly.

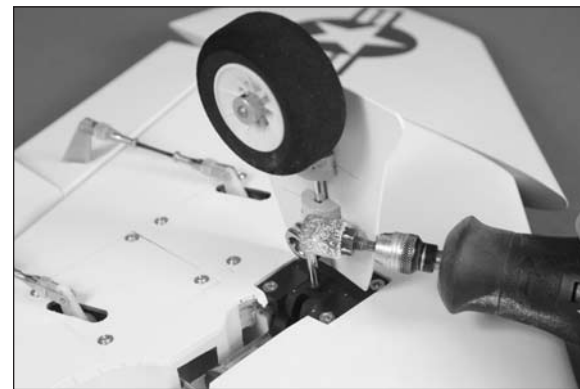

- 14. Slide the landing gear door so the top block is resting against the coil of the landing gear strut. Apply a thin bead of canopy glue along the front and back of the strut against the landing gear door. Rotate the door a few times to work the glue behind the strut.



- 15. Retract the landing gear using the radio system. This will set the correct angle for the landing gear door against the wing. Allow the glue to cure overnight before moving the gear back to the down position.



- 16. Repeat steps 2 through 15 to install the second landing gear door.

## Rudder and Elevator Servo Installation

### Required Parts

Fuselage assembly Transmitter  
Receiver Receiver battery  
Hardwood block, 15mm x 13mm x 6mm (4)  
Servo with hardware (rudder and elevator)

### Required Tools and Adhesives

Phillips screwdriver: #1  
Pencil Razor saw  
Thin CA 5-minute epoxy  
Mixing cup Mixing stick  
Drill Drill bit: 5/64-inch (2mm)  
Medium grit sandpaper

- 1. Use a pencil to mark the servo mounting plate in the fuselage for the servo locations.

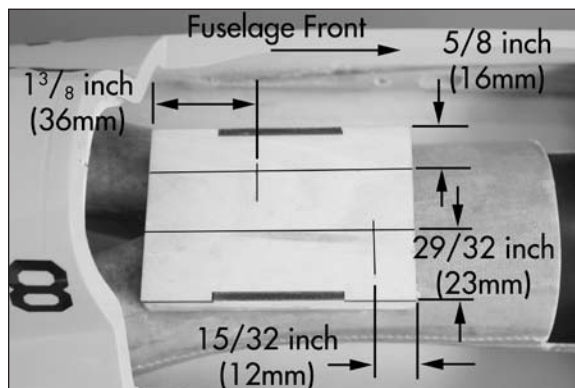

- 2. Prepare the elevator servo using the grommets and eyelets included with the servo. Position the servo so the bottom of the mounting tabs are aligned with the line drawn on the plate. The servo output will align with the line that is 1 3/8-inch (36mm) from the rear of the plate. Use a pencil to mark the plate for the sides of the servo.



- 3. Prepare and epoxy the servo mounting blocks as shown in the section "Aileron and Flap Servo Installation." Allow the epoxy to fully cure before proceeding.

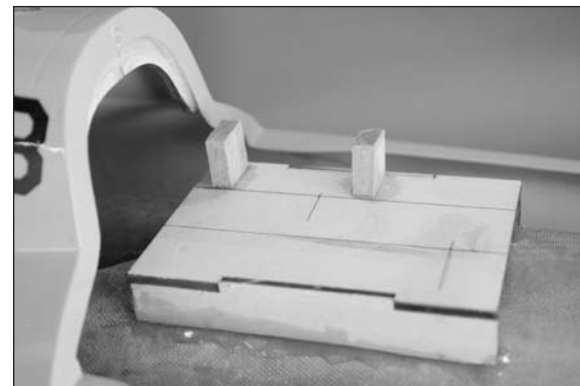

- 4. Mount the elevator servo as shown in the section "Aileron and Flap Servo Installation." Make sure to center the elevator servo and prepare the servo horn before installing the servo. The elevator and rudder servo will use a short side of a standard JR 4-way horn. Make sure to trim the servo mounting block to allow fitting of the servo lead as shown in the aileron and flap servo mounting section.

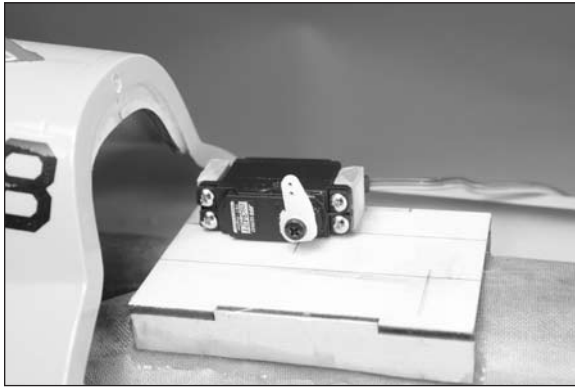

- 5. Repeat steps 2 through 4 to install the rudder servo. Make sure the output of the rudder servo is aligned with the mark that is 15/32-inch (12mm) from the front of the plate when marking for the servo mounting blocks.

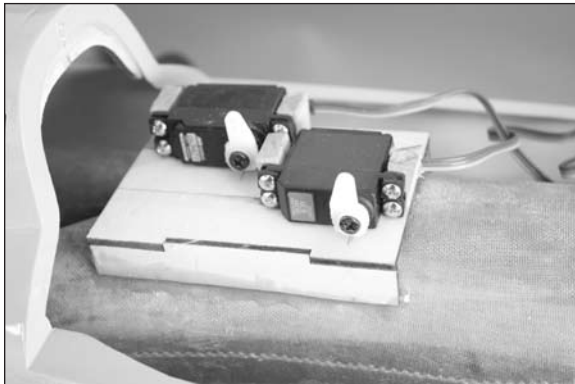

## Rudder Installation

### Required Parts

Fuselage assembly	Transmitter
Receiver	Receiver battery
Pin hinge (2)	Rudder
Rudder torque rod	Torque rod end
Metal clevis (2)	Silicone tubing
2mm nut (2)	
2mm x 360mm pushrod with 295mm carbon tubing	

### Required Tools and Adhesives

Side cutters	Petroleum jelly
5-minute epoxy	Toothpick
Mixing cup	Mixing stick
Rubbing alcohol	Paper towel
Low-tack tape	Thin CA
Needle nose pliers	Threadlock
Hobby knife with #11 blade	
Medium grit sandpaper	

- 1. Use side cutters to trim one end of each of the hinges to the length shown. The 11/16-inch (17mm) hinge is used at the top of the rudder.

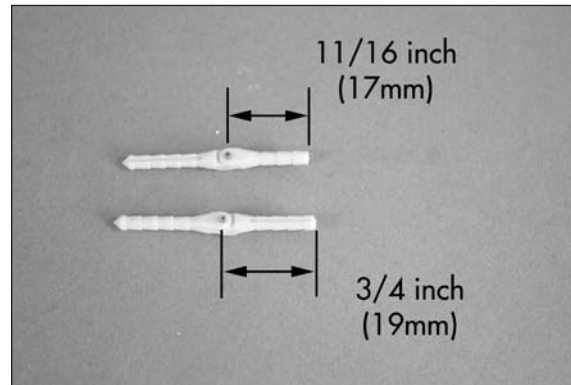

### ***Etips***

Dipping the hinge knuckles in heated petroleum jelly (in a liquid state) is easier than trying to apply it with a toothpick in the gel state.

- 2. Apply a small amount of petroleum jelly to the knuckle of the hinge to prevent epoxy from entering the hinge.

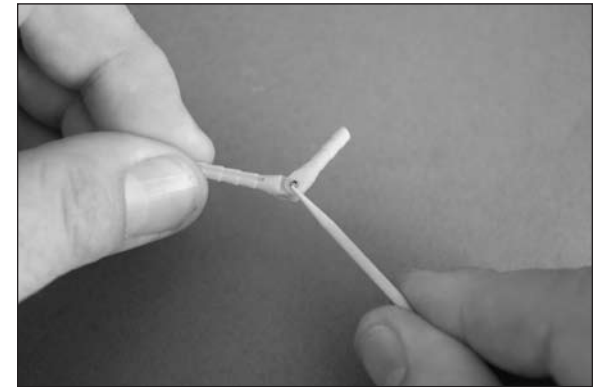

- 3. Check the fit of the hinge. The pin will align with the hinge line of the rudder. Position the hinge so it will move perpendicular to the rudder.

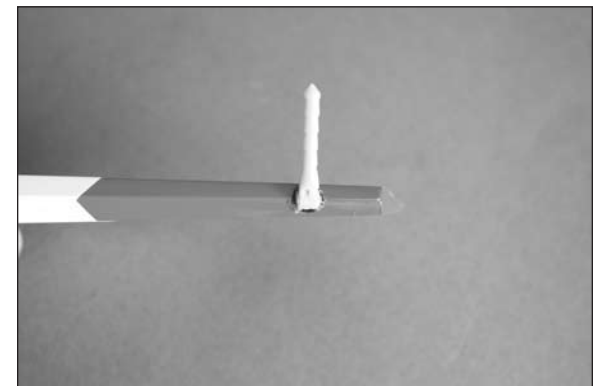
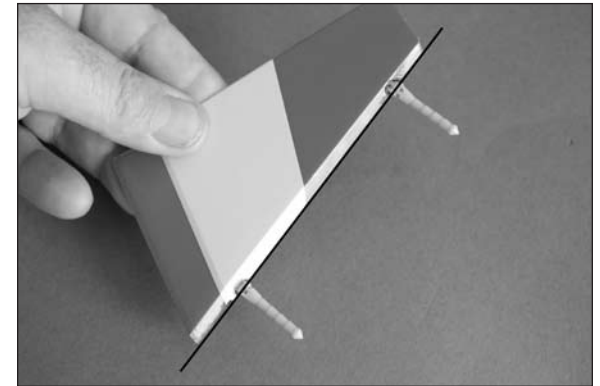

- 4. Check the fit of the torque rod. It must fit flush with the leading edge of the rudder. Make sure that the threaded end of the torque rod is on the outside of the rudder.

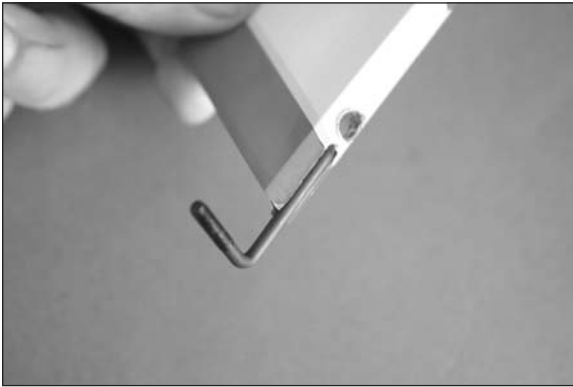

- 5. Remove the torque rod and use medium grit sandpaper to lightly sand the torque rod where it comes in contact with the rudder.

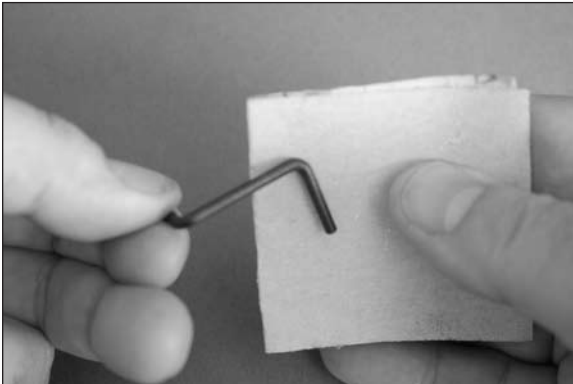

- 6. Mix a small amount of 5-minute epoxy. Apply the epoxy in the holes for the hinges and torque rod. Fit the hinges and torque rod to the rudder. Use a paper towel and rubbing alcohol to remove any excess epoxy before it can cure.

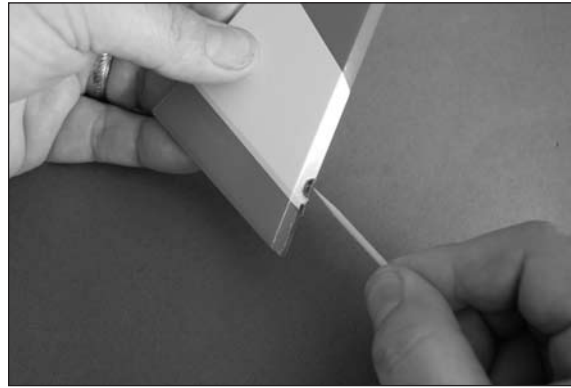

- 7. Once the epoxy has fully cured, thread the torque rod end on the rudder torque rod so it is flush with the end of the rod.

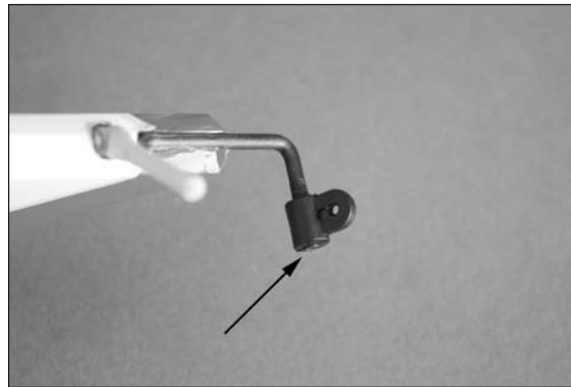

- 8. Center the carbon tube on the pushrod and apply thin CA to the pushrod and carbon tube to glue them together. Allow the CA to wick in between the two for a secure bond.

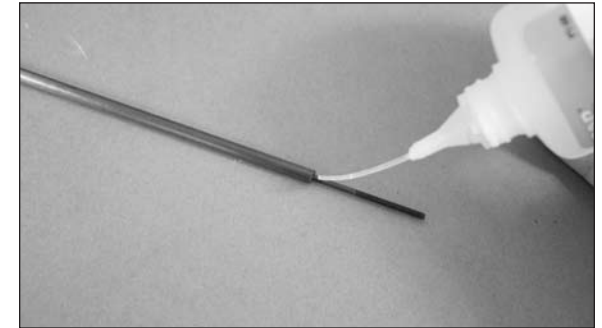

- 9. Cut a piece of silicone tubing and slide it onto the clevis. Thread a 2mm nut on the pushrod, then the clevis to the pushrod. Prepare both ends of the pushrod at this time. Make sure to use threadlock on the clevis and nut to prevent them from vibrating loose.

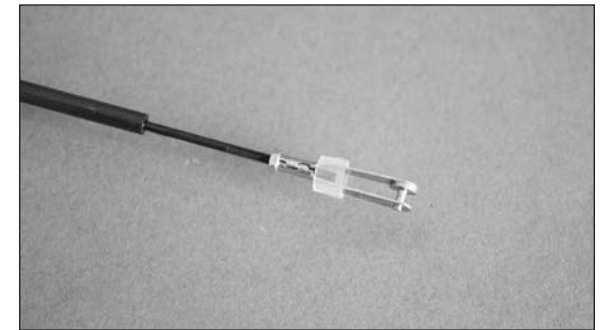

- 10. Attach the clevis to the torque rod. Slide the silicone tubing over the clevis.

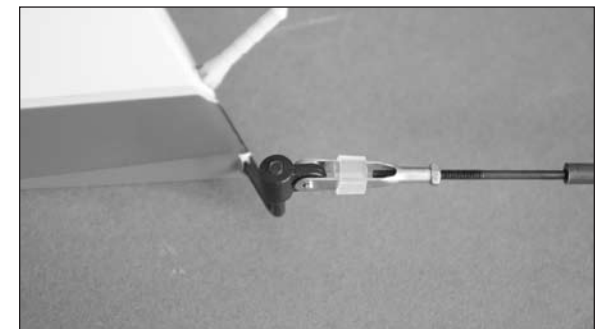

- 11. Fit the rudder to the fin while guiding the pushrod into the fuselage. With the rudder tight against the fin, check the length of the pushrod. Adjust the pushrod length so it is close to aligning with the rudder servo horn. Once adjusted, remove the rudder and use needle nose pliers to tighten the nut against the clevis at the rudder. Adjusting the clevis at the rudder will be difficult once the rudder has been hinged to the fin.

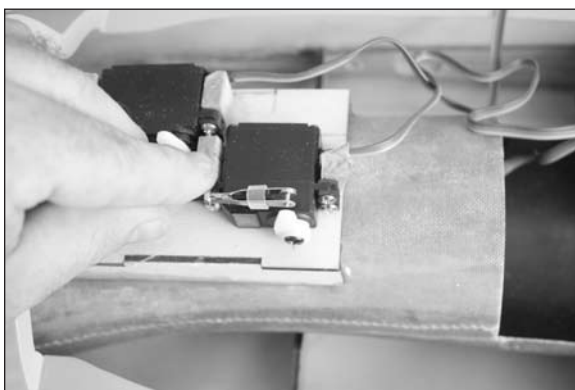

- 12. With the rudder removed, mix a small amount of 5-minute epoxy. Apply the epoxy to the hinges and in the holes in the fin. Position the rudder and use low-tack tape to hold it while the epoxy cures.



### ***E-tips***

Always use threadlock on metal-to-metal fasteners to prevent them from vibrating loose.

- 13. Once the epoxy has cured, remove the tape from the rudder. Use the radio to center the rudder servo. Attach the clevis to the servo horn on the inner hole and adjust the length of the pushrod so the rudder is centered. Tighten the 2mm nut against the clevis, then slide the silicone tubing over the clevis.

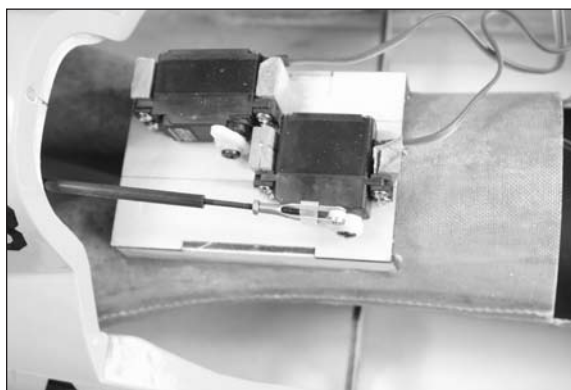

## ***Elevator Installation***

### ***Required Parts***

Fuselage assembly	Transmitter
Receiver	Receiver battery
Metal clevis (2)	2mm nut (2)
Silicone tubing	3mm x 6mm socket head screw
Tail cone	Clear tape
3mm x 12mm socket head screw (4)	
2mm x 290mm pushrod with 225mm carbon tube	

### ***Required Tools and Adhesives***

Thin CA	Ruler
Threadlock	Hex wrench: 2.5mm

### ***E-tips***

Always use threadlock on metal-to-metal fasteners to prevent them from vibrating loose.

- 1. Secure the elevator control arm to the joiner wire using a 3mm x 6mm socket head screw and a 2.5mm hex wrench. Make sure the arm is centered between the collars and the screw is tightened on the flat area of the elevator torque rod.

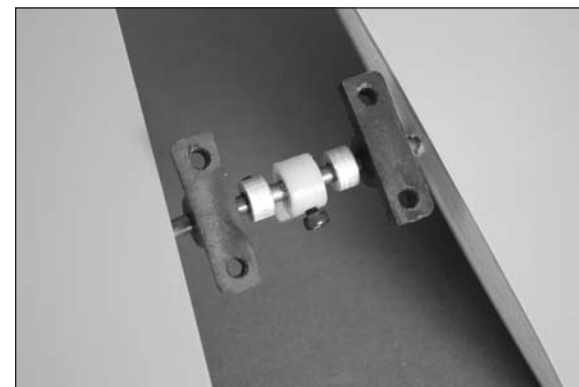



## ***Etips***

Always use threadlock on metal-to-metal fasteners to prevent them from vibrating loose.

- 2. Secure the elevator mounting brackets to the fuselage using four 3mm x 12mm socket head screws and a 2.5mm hex wrench.



- 3. Center the carbon tube on the pushrod and apply thin CA to the pushrod and carbon tube to glue them together. Allow the CA to wick in between the two for a secure bond.

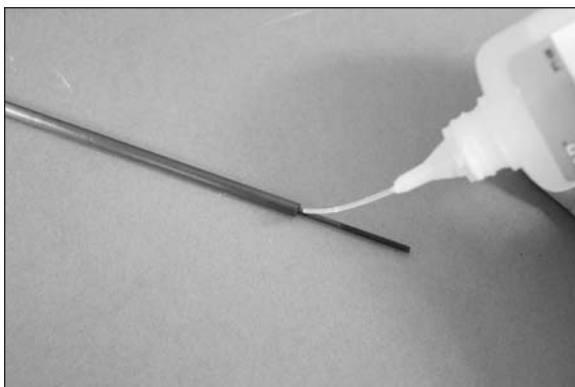

- 4. Cut a piece of silicone tubing and slide it onto the clevis. Thread a 2mm nut on the pushrod, then the clevis to the pushrod. Prepare both ends of the pushrod at this time. Make sure to use threadlock on the clevis and nut to prevent them from vibrating loose.

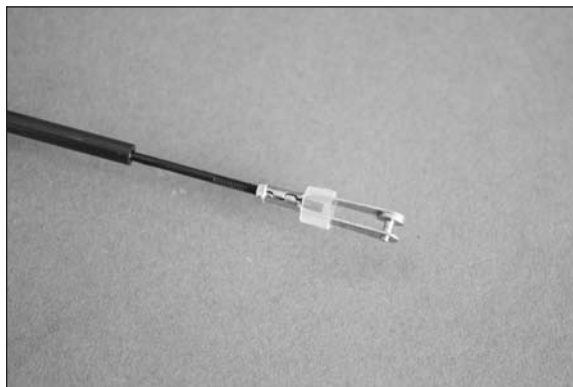

- 5. Attach the clevis to the outer hole of the elevator control arm.

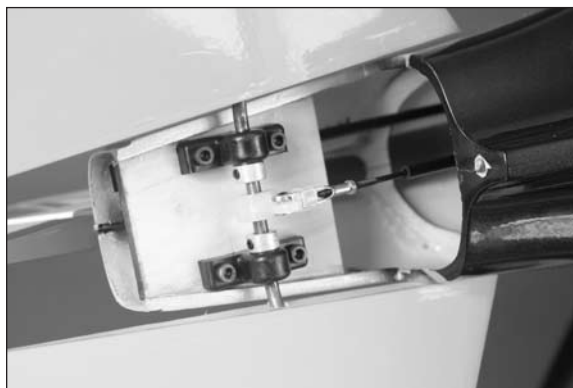

- 6. Connect the clevis to the outer hole of the elevator servo horn. Make sure to use threadlock on the clevis and nut to prevent them from vibrating loose.

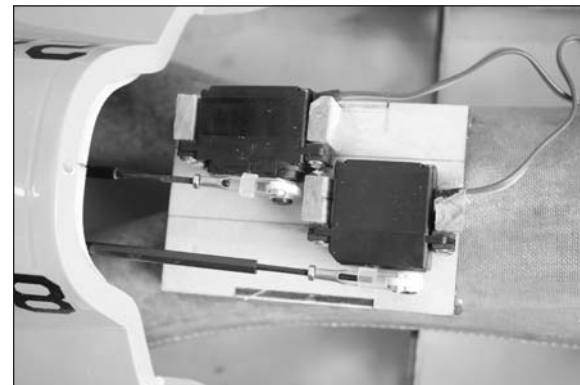

- 7. With the radio on and the elevator servo centered, adjust the length of the pushrod so the distance from the tip of the elevator and the line projected from the fuselage shown in the photo below measures 9/16-inch (14mm). Use the hatch line for a reference to project the reference line to measure from.

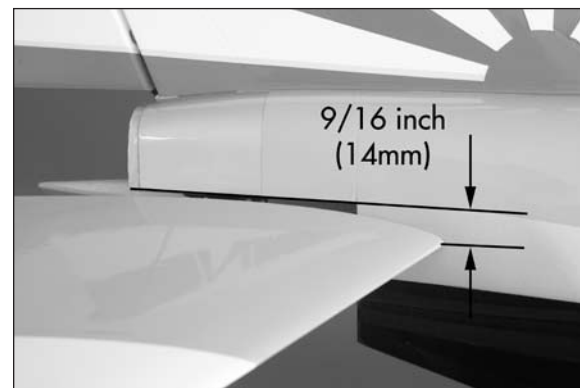

- 8. Once the elevator position has been set, slide the silicone keepers onto both clevises to keep the clevises from opening accidentally.

- 9. Check the operation of the elevator using the radio system. You may need to change the servo reversing at the transmitter depending on the radio system and servos used to achieve the correct direction of throw.

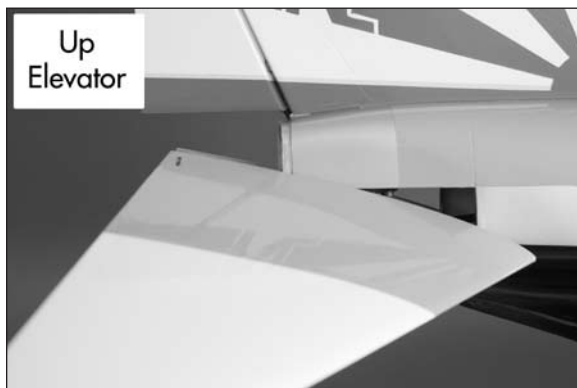
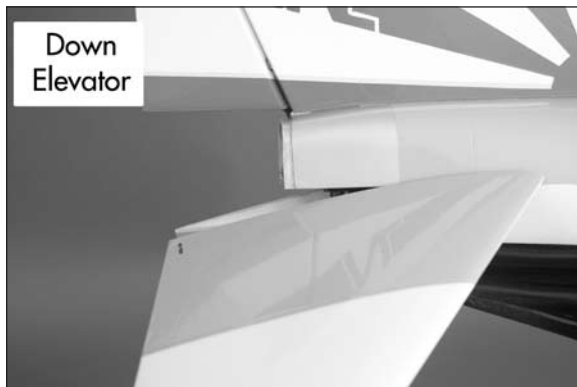

- 10. Use the tape included with the model to attach the tail cone to the fuselage.



## Fan Installation

### Required Parts

Fan assembly                  Fuselage assembly  
3mm x 10mm self-tapping screw (4)

### Required Tools and Adhesives

Thin CA                          Phillips screwdriver: #1  
Flexible tape                  Pin vise  
Pencil                              Felt-tipped pen  
Ruler                                Hobby scissors  
Drill bit: 5/64-inch (2mm)

➔ The fan used in our instruction model was a pre-production unit and did not have a label. The location of the label is called out as a reference for production units.

- 1. Locate the fan unit. View the fan unit and use the drawing provided to determine the top and bottom of the fan.

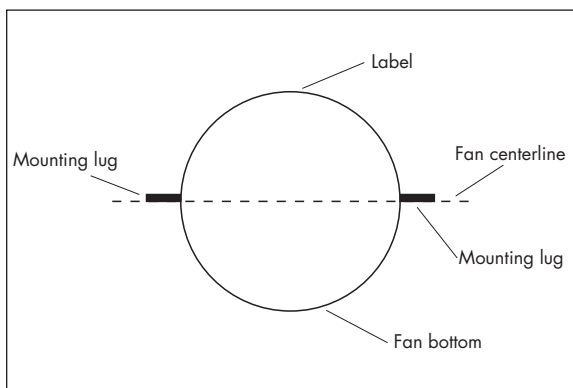

- 2. Follow the instructions included with the fan unit to prepare it for installation in your model.

- 3. Fit the fan housing into the fuselage. Slide the fan forward to make sure it is fully inserted into the intake.

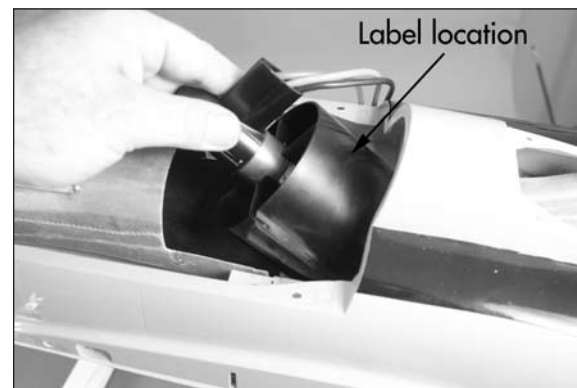

- 4. Use a pin vise and 5/64-inch (2mm) drill bit to drill the four holes for the fan mounting screws. Make sure to drill the holes against the tabs of the housing so the fan does not slide forward or aft in the fuselage.

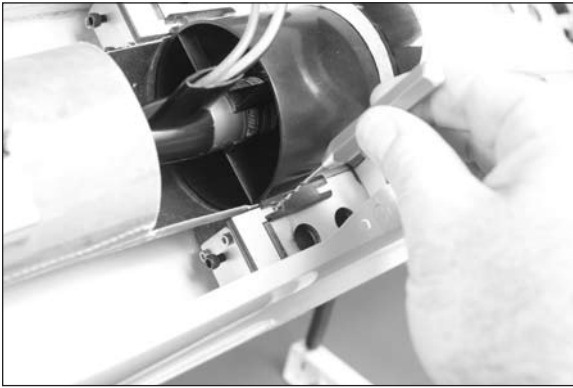

### ***E-tips***

You can also mount the pin vise in a drill so it can reach down inside the fuselage, saving some time when drilling the holes.



- 5. Use a #1 Phillips screwdriver to thread a 3mm x 10mm self-tapping screw into each of the four holes for mounting the fan unit.

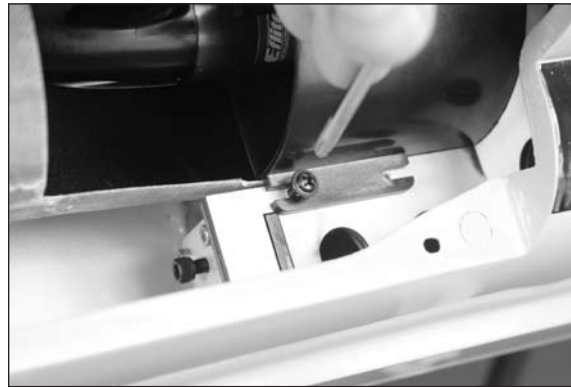

- 6. Remove the screws and place 2–3 drops of thin CA in each hole to harden the surrounding wood. This hardens the wood, making the screws more secure.



- 7. Secure the fan unit to the fuselage using four 3mm x 10mm self-tapping screws. Tighten the screws using a #1 Phillips screwdriver.

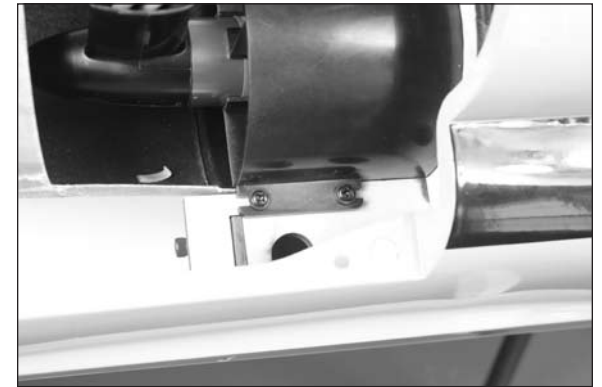

- 8. Use hobby scissors to trim the fan cover. Make sure to make an opening in the top for the fan fairing as well.

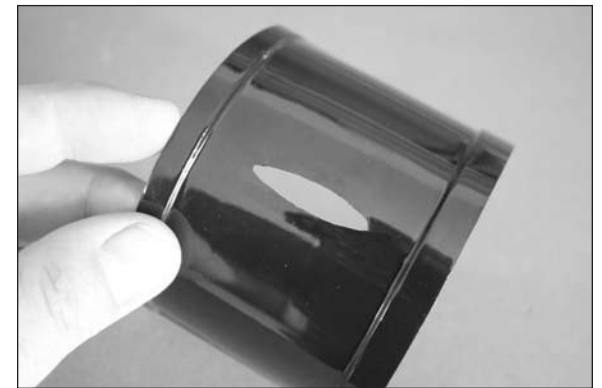

- 9. Cut a notch at the front of the cover to fit over the fan mounting lugs.

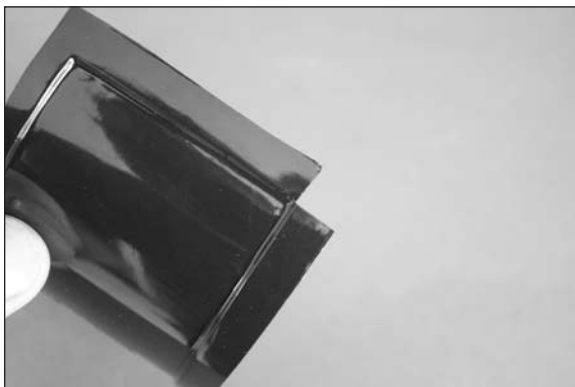

- 10. Fit the cover to the fan, trimming as necessary to fit the cover tightly over the fan and exhaust tube. Use flexible tape to secure the cover to the fan and exhaust tube. Make sure to tape over any areas that would allow air to pass between the airflow of the propulsion system and the inside of the fuselage.

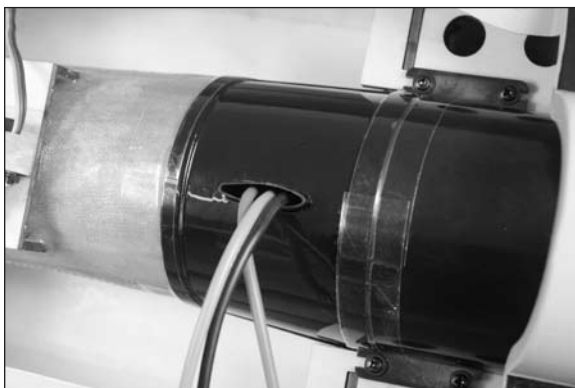

## Nose Gear Installation

### Required Parts

Fuselage assembly	Transmitter
Receiver	Receiver battery
Silicone tubing	Metal clevis (2)
2mm nut (2)	Threaded rod, 2mm x 40mm
Servo with hardware	
3mm x 8mm socket head screw (4)	
Aluminum wheel collar with setscrew, 3.5mm	
Aluminum wheel spacer, 3.5mm	
Wheel, 1 <sup>5</sup> / <sub>16</sub> -inch (33mm)	
Dual wheel axle adapter set	

### Required Parts (Fixed Gear Specific)

Fixed nose gear assembly

### Required Parts (Retract Specific)

Nose gear retract assembly

Nose gear strut

### Required Tools and Adhesives

Side cutter	Hobby knife with #11 blade
Clear tape	Threadlock
Pin vise	Drill bit: 1/16-inch (1.5mm)
Pencil	Hex wrench: 1.5mm, 2.5mm
Flat file	Phillips screwdriver: #1

➔ The installation of the retracts and fixed gear follow the same procedure. The only difference is the installation of the nose gear strut, which has been highlighted in gray.

- 1. Use a #1 Phillips screwdriver to remove the four 2mm x 8mm self-tapping screws that secure the nose gear cover to the fuselage. Set the cover and screws aside until later in the section of the manual.

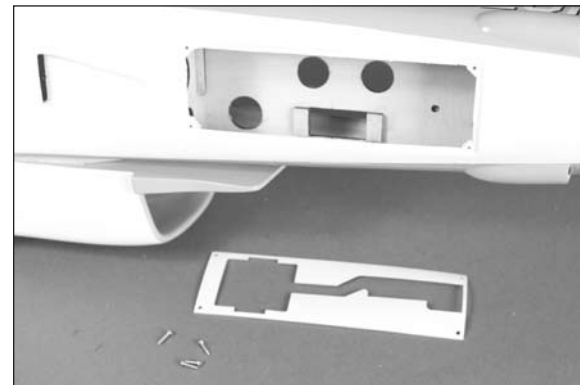

- 2. Place the grommets and brass eyelets into the servo mounting tabs. Note the positioning of the brass eyelets, as the servo will be mounted to the top of the plate in the fuselage.



- 3. Place the servo in the opening with the servo output facing the rear of the fuselage. Use a pencil to mark the locations for the servo mounting screws.

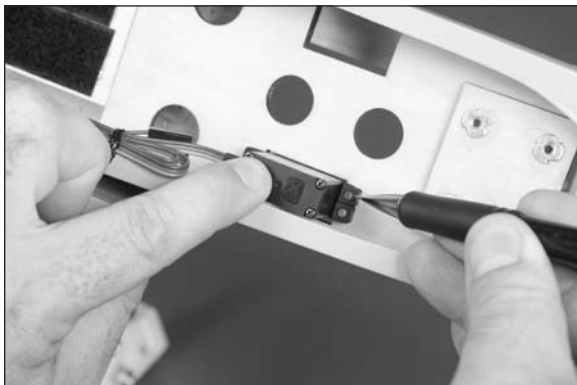

- 4. Use a pin vise and 1/16-inch (1.5mm) drill bit to drill the holes for the servo mounting screws.

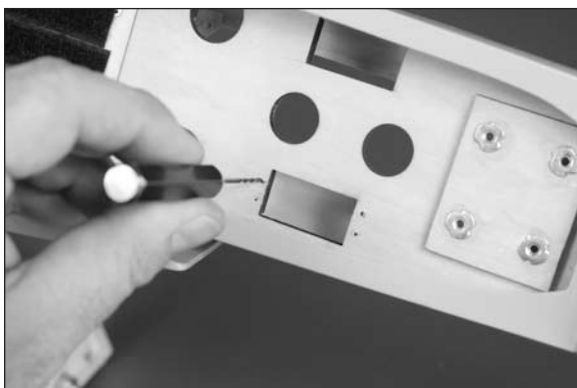

- 5. Use a #1 Phillips screwdriver to thread a servo mounting screw into the mounting holes for the steering servo. Remove the screw after cutting the threads in the plywood.

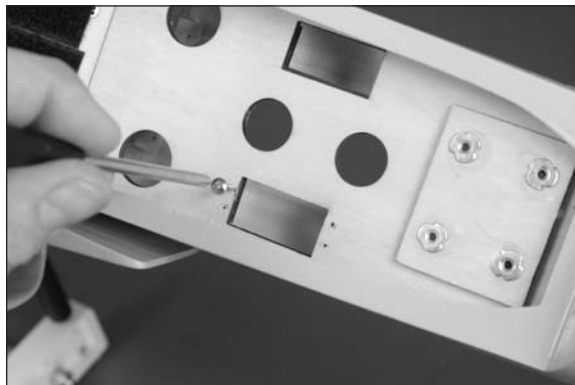

- 6. Place 2-3 drops of thin CA in each of the holes. This will harden the threads made by the screws making them more secure when the steering servo is installed.



- 7. Center the steering servo using the radio system. The steering servo will use the short side of a standard JR 4-way horn. Use side cutters to remove any arms from the horn that may interfere with the operation of the servo. Secure the horn to the servo using a #1 Phillips screwdriver and the servo from the servo.

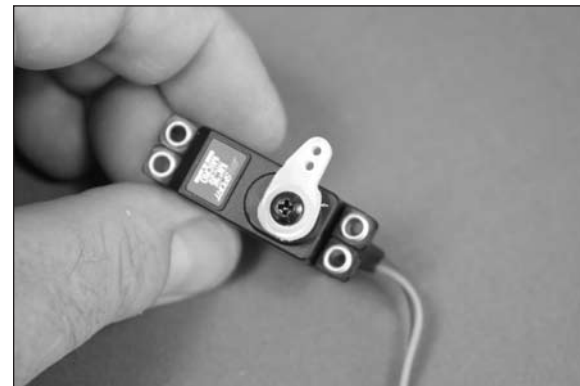

- 8. The steering linkage will be connected to the hole in the servo that is 7/16-inch (11mm) from the center of the arm as illustrated in the photo above.
- 9. Install the steering servo in from the top of the fuselage using the hardware provided with the servo and a #1 Phillips screwdriver. The servo output faces the rear of the fuselage.



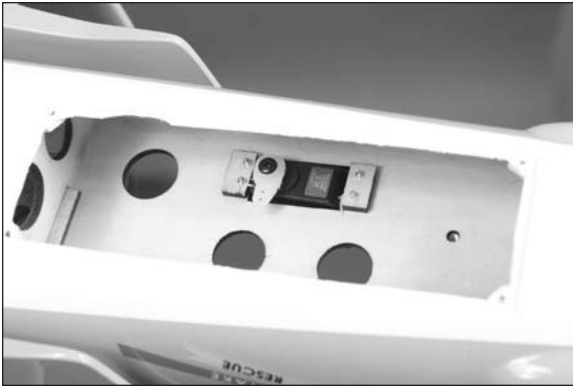

***Etips***

We have designed the nose gear strut to work with both the fixed gear and the suggested retracts. These struts are designed for the weight and speeds of the F-4 Phantom. Use the struts supplied with the kit for the retract assembly.

- A. Use the radio system to move the nose gear retract to the UP position. Use a 1.5mm hex wrench to loosen the screw on the steering arm and wheel collar to remove the strut from the mechanism.

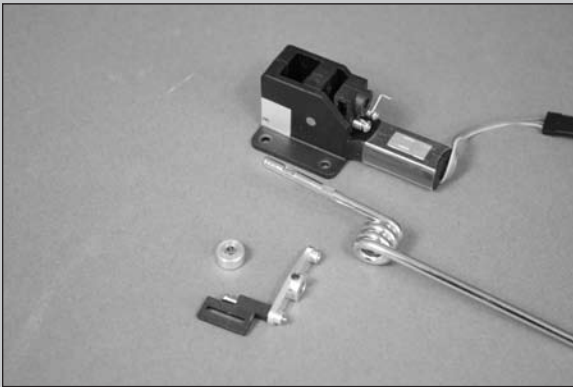

- B. Use a 1.5mm hex wrench to secure the steering arm by tightening the setscrew on the lower flat of the nose gear strut. Make sure the arm is positioned as shown in the photo. Install the supplied nose gear strut in the retract mechanism and tighten the setscrews using a 1.5mm hex wrench. The setscrews should align with the flat spots on the nose gear leg.

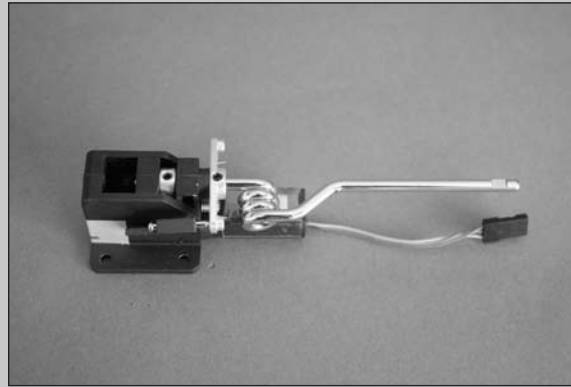

- 10. Use a hobby knife with a #11 blade to trim a 1/4-inch (6mm) section of the silicone tubing.

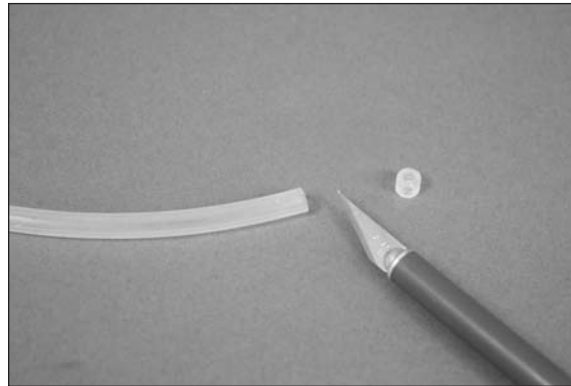

***Etips***  
Always use threadlock on metal-to-metal fasteners to prevent them from vibrating loose.

- 11. Slide the piece of silicone tubing on one of the metal clevises. Assemble the steering linkage by threading a 2mm nut and metal clevis on either end of the 2mm x 40mm threaded rod as shown. Thread the clevis without the tubing so the threads are barely visible between the forks of the clevis. Adjust the linkage so it is 2<sup>5</sup>/<sub>8</sub>-inches (67mm) in length. Use pliers to tighten the nut against the clevis to keep the clevis from moving.

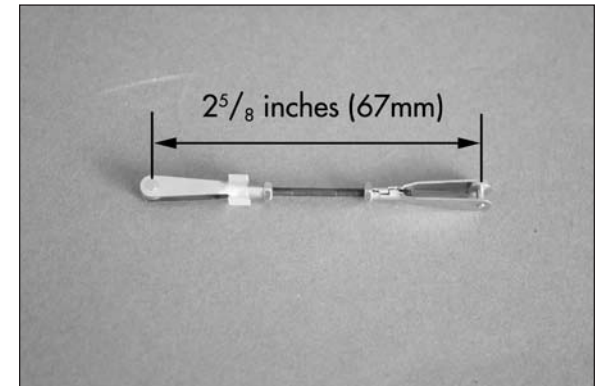

- 12. Connect the clevis without the tubing to the steering arm of the nose gear assembly.

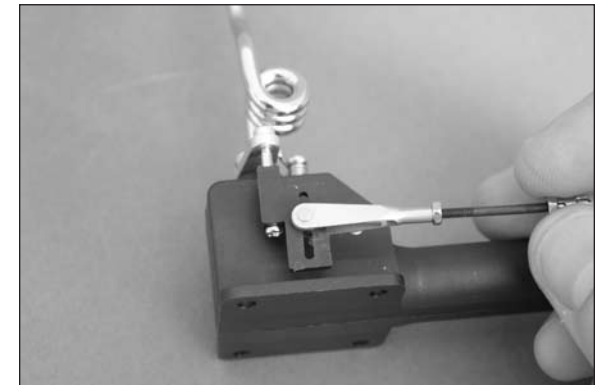

- 13. Use a flat file to make two flat areas on the nose gear axle that are 1/4-inch (6mm) wide.

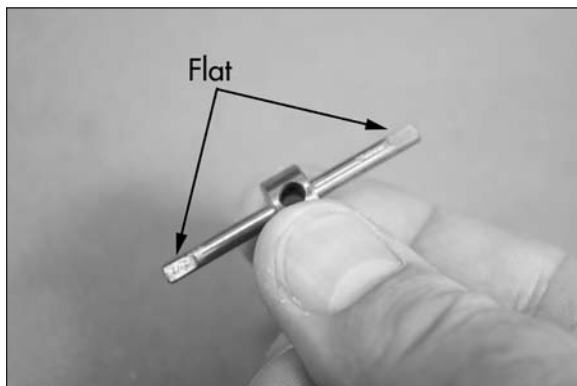

### ***E-tips***

Always use threadlock on metal-to-metal fasteners to prevent them from vibrating loose.

- 14. Position the axle on the nose gear so it is 3<sup>3</sup>/<sub>16</sub>-inches (81mm) from the bottom of the steering arm to the centerline of the axle. Use a 1.5mm hex wrench to tighten the setscrews, securing the axle to the nose gear.

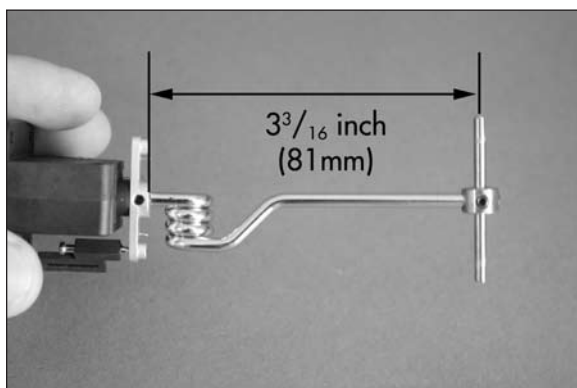

### ***E-tips***

The end of the axles may have a slight bur on them from the factory. If the wheel is hard to install use a file to remove this bur.

- 15. Attach the wheels to the axle using two wheel collars. Use a 1.5mm hex wrench to tighten the setscrews securing the wheel collars to the axle.



### ***E-tips***

Cut a 1/2-inch (13mm) piece of silicone tubing and slide it on a 2.5mm hex wrench. The 3mm screw can then be placed in the tubing and against the hex wrench so it can be easily installed to secure the landing gear.



### ***E-tips***

Always use threadlock on metal-to-metal fasteners to prevent them from vibrating loose.

- 16. Secure the nose gear assembly in the fuselage using four 3mm x 8mm socket head screws. Connect the linkage to the steering servo horn and check that the steering is centered when the steering servo is centered. Once the linkage is set, tighten the 2mm nut against the clevis using pliers so the clevis doesn't vibrate loose. Slide the silicone over the forks of the clevis and install the screw to secure the servo horn to the servo using a #1 Phillips screwdriver.

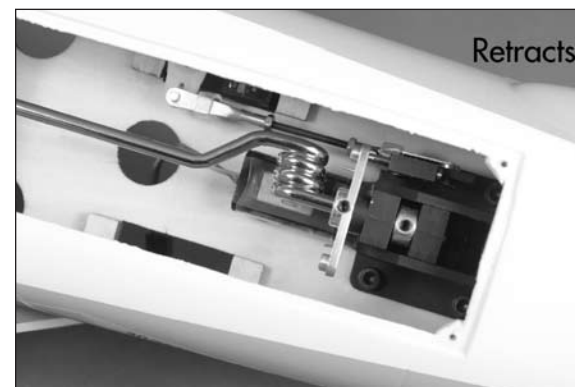

- 17. Attach the nose gear cover to the fuselage using a #1 Phillips screwdriver and the four 2mm x 8mm self-tapping screws removed in step 1.



- 18. Cycle the retract unit to make sure the nose gear strut and tires clear the gear door openings. Some slight trimming may be required.

***Etips***

Add clear tape to both sides of the nose gear door to help secure it to the fuselage.

## Receiver and Speed Control Installation

### Required Parts

Fuselage assembly    Harness from retract assembly  
 18-inch (457mm) servo extension (retracts)  
 9-inch (228mm) servo extension  
 Steering Y-harness when using the same channel for both steering and rudder  
 Hook and loop tape  
 Y-harness (flaps)  
 Y-harness (optional for ailerons if not using separate channels)

### Required Tools and Adhesives

Scissors                      String  
 Two-sided tape            Tie-wraps

### 8-CHANNEL RECEIVER ASSIGNMENTS FOR DX8 USING SEPARATE CHANNELS FOR AILERONS AND NOSE GEAR STEERING:

Throttle	Speed Control
Aileron	Right Aileron
Elevator	Elevator
Rudder	Rudder
Gear	Flaps (requires Y-harness)
Aux 1	Left Aileron
Aux 2	Nose Gear Steering
Aux 3	Retracts

***Etips***

Programs for the F-4 Phantom using the DX8 are available for download on the Spektrum website.

- 1. Use scissors to cut a piece of hook and loop tape and apply it to the back of the speed control.



- 2. Use the hook and loop tape to attach the speed control to the top of the fan. Route the leads for the speed control forward in the fuselage. Use two-sided tape to secure the switch where it can be accessed when the canopy is removed.

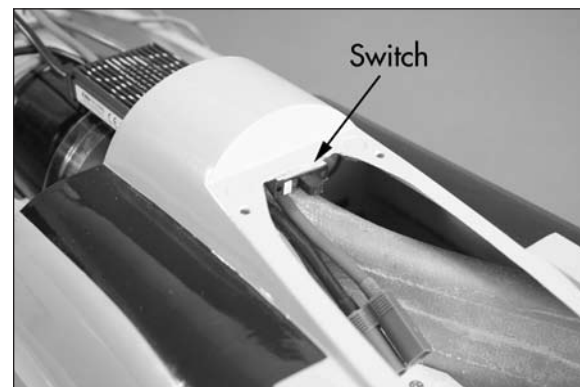



- 3. Connect the leads from the motor and speed control. Use tie-wraps (not included) to secure the wiring so it is not moving around inside the fuselage.

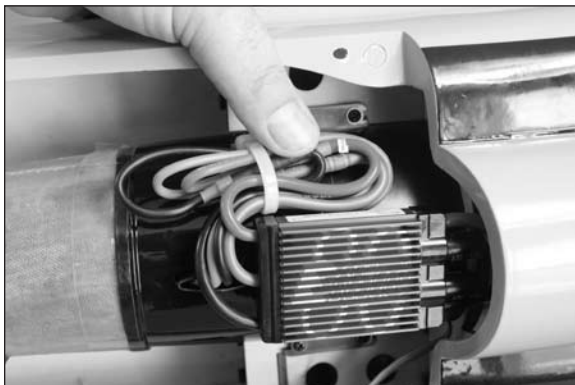

- 4. Use scissors to cut a small piece of hook and loop tape. Use the tape to secure the receiver in the fuselage. Plug the leads for the servos into the receiver as outlined earlier in this section of the manual.

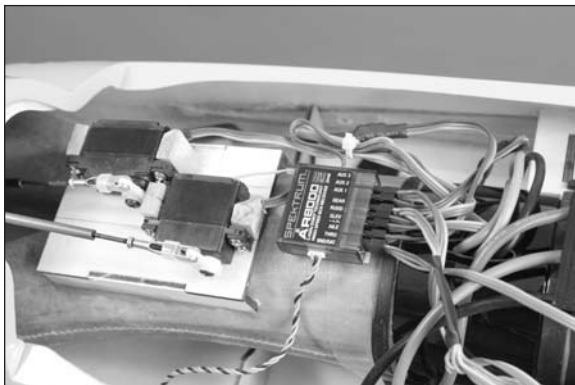

- 5. Use scissors to cut a small piece of hook and loop tape. Use the tape to secure the remote receiver in the fuselage.

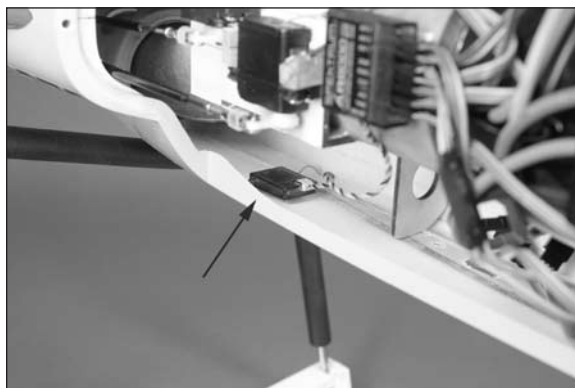

- 6. Attach a 18-inch (457mm) servo extension to the nose gear retract and route it back to the Y-harness for the retracts. The nose gear steering can either be connected directly to the receiver using a 9-inch (228mm) extension, or by a 6-inch Y-harness plugged into the rudder channel of the receiver with a 9-inch (228mm) extension. Make sure to use a string or dental floss on all connections to keep them from unplugging. Secure the leads inside the fuselage using clear tape.



## Motor Battery Installation

### Required Parts

Fuselage assembly    Hook and loop tape  
 Motor battery        Hook and loop strap

### Required Tools and Adhesives

Scissors

- 1. Apply the hook and loop tape to the bottom of the battery. This will keep the battery from sliding in the fuselage, which could change the center of gravity.



- 2. Apply the mating hook and loop tape to the battery tray in the fuselage.



- 3. Secure the battery in the fuselage using the hook and loop strap. Make sure the strap is not pinching any of the servo leads on the bottom side of the battery tray.

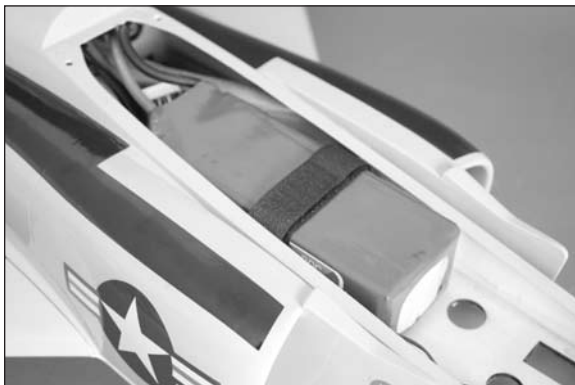

## Canopy Assembly

### Required Parts

Canopy                      Cockpit interior  
Pilot (optional) (PKZ4414) (2)

### Required Tools and Adhesives

Hobby scissors              Clear tape  
Silicone adhesive

- 1. Locate the cockpit interior and use hobby scissors to trim the interior along the inscribed line. Trim the interior a little outside the line so it can be trimmed to fit to the canopy.



- 2. Use hobby scissors to trim the height of the pilots so they are 1 1/4-inches (31mm) in height.

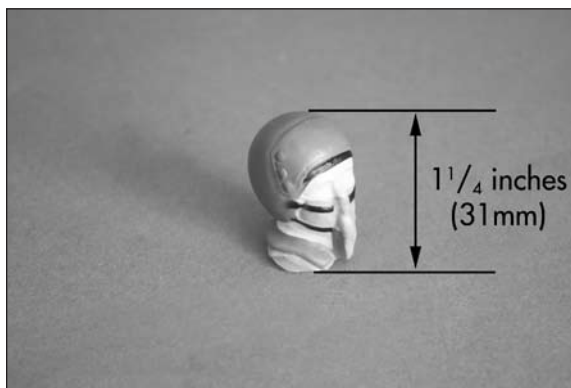

- 3. Use silicone adhesive to glue the pilots to the cockpit interior.

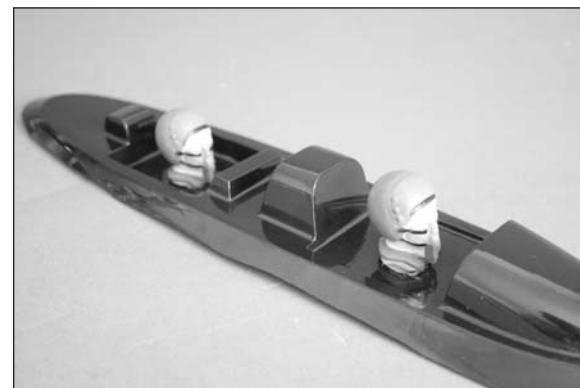

### ***E-tips***

You can add more detail to the F-4 Phantom 32 cockpit by painting parts of the cockpit with different colors so it looks more realistic.

- 4. Place the interior in the canopy. It may be necessary to bend the interior slightly to fit past the canopy frame.



- 5. Use clear tape to secure the interior inside the canopy.

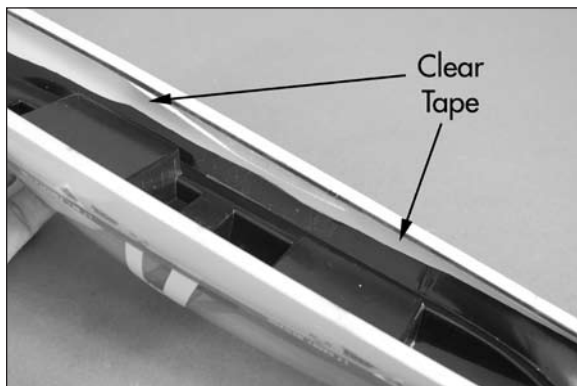

## Decal Placement

### Required Parts

Decal sheet      Assembled airframe

### Required Tools and Adhesives

Hobby scissors      Hobby knife with #11 blade

- 1. Your F-4 already comes with the majority of decals applied, but also includes an extra set of decal nomenclature. Apply the decals to your model using the photos located in this section of the manual, the box art from your model and on Page 43.





## Center of Gravity

### Required Parts

Assembled airframe

### Required Tools and Adhesives

Balancing stand      Felt-tipped pen



**CAUTION:** Do not inadvertently skip this step or property damage and injury could occur.

When balancing your model, adjust the motor battery as necessary so the model is level or slightly nose down. This is the correct balance point for your model. You should find the CG to be very close with the battery installed as shown in this manual. Mark the location of the battery on the battery tray using a felt-tipped pen so it can be returned to this position, if it is removed from your model.

After the first flights, the CG position can be adjusted for your personal preference.

- 1. Attach the wings to the fuselage following the procedure outlined earlier in this manual.
- 2. The recommended Center of Gravity (CG) location for your model is  $5\frac{11}{16}$  to  $6\frac{1}{8}$ -inches (145 to 155mm) back from the leading edge of the wing at the root as shown with the battery pack installed. Mark the location of the CG on the top of the wing with a felt-tipped pen.

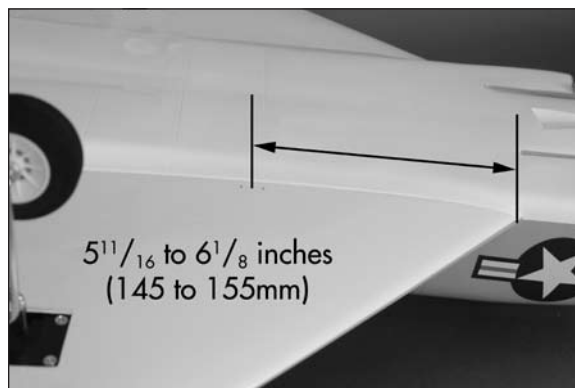

- 3. When balancing your model, support the plane upright at the marks made on the bottom of the wing with your fingers or a commercially available balancing stand. This is the correct balance point for your model. Make sure your model is assembled and ready for flight before balancing.

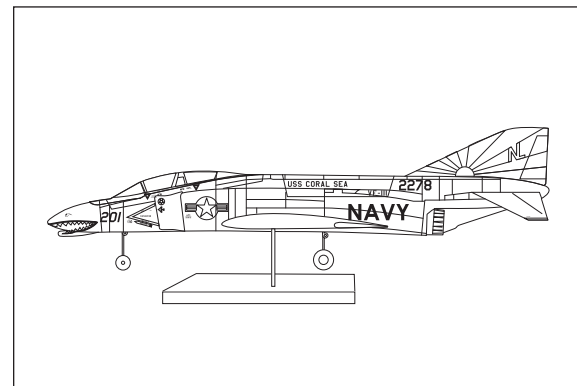

**E-tips**

If you have installed retracts, balance your model with the gear down.

## Control Throws

- 1. Turn on the transmitter and receiver of your model. Check the movement of the rudder using the transmitter. When the stick is moved right, the rudder should also move right. Reverse the direction of the servo at the transmitter if necessary.
- 2. Check the movement of the elevator with the radio system. Moving the elevator stick toward the bottom of the transmitter makes the airplane elevator move up.
- 3. Check the movement of the ailerons with the radio system. Moving the aileron stick right makes the right aileron move up and the left aileron move down.
- 4. Use a ruler to adjust the throw of the elevator, ailerons and rudder. Adjust the position of the pushrod at the control horn to achieve the following measurements when moving the sticks to their endpoints.

***IMPORTANT:*** Use caution with high rates on the elevator and ailerons. High rates are only used for snap and spin aerobatic maneuvers. Middle rates are suggested for takeoff and landings. Low rates are suggested for standard flight maneuvers. If your radio only has the option for two rates, use the middle and low rates.

### Ailerons

#### Up

High	11mm	Expo 10%
Mid	9mm	Expo 8%
Low	7mm	Expo 5%

#### Down

High	9mm	Expo 10%
Mid	7mm	Expo 8%
Low	6mm	Expo 5%

### Elevator

#### Up and down

High	26mm	Expo 10% (up/down)
Mid	21mm	Expo 5% (up/down)
Low	16mm	Expo 0% (up/down)

### Rudder

#### Left and right

High	22mm	Expo 10% (left and right)
Mid	18mm	Expo 5% (left and right)
Low	15mm	Expo 0% (left and right)

### Flaps

Mid/Take Off	11mm down
Full/Landing	30mm down

### Flap Elev Mix

Mid/Take Off	1 mm up elevator
Full/Landing	2 mm up elevator

### Nose Gear Steering

High rate mix	50%
Low rate Mix	30%

## *E-tips*

The F-4 Phantom does not always require full flaps for landing. We recommend using full flaps for landings in no wind or light headwind situations. Use half flaps for landings in strong headwinds or crosswinds.

## *E-tips*

Measurements are taken at the inner or widest point on the control surface.

These are general guidelines measured from our own flight tests. You can experiment with higher rates to match your preferred style of flying.

## *E-tips*

Travel Adjust and Sub-Trims are not listed and should be adjusted according to each individual model and preference.

**NOTICE:** Always re-binding the radio system once all the control throws are set. This will keep the servos from moving to their endpoints until the transmitter and receiver connect.

## Preflight

### Check Your Radio

Before going to the field, make sure your batteries are fully charged per the instructions included with your radio. Charge the transmitter and motor battery for your airplane. Use the recommended charger supplied with your particular radio system, following the instructions provided with the radio. In most cases, the radio should be charged the night before going out flying.

Before each flying session, be sure to range check your radio. See your radio manual for the recommended range and instructions for your radio system. Each radio manufacturer specifies different procedures for their radio systems. Next, run the motor. With the model securely anchored, check the range again. The range test should not be significantly affected. If it is, do not attempt to fly! Have your radio equipment checked out by the manufacturer.

Double-check that all controls (aileron, elevator, rudder and throttle) move in the correct direction.

Check the radio installation and make sure all the control surfaces are moving correctly (i.e., the correct direction and with the recommended throws).

Check all the control horns, servo horns, and clevises to make sure they are secure and in good condition.

## Range Test Your Radio

Before each flying session, and especially with a new model, it is important to perform a range check. It is helpful to have another person available to assist during the range check. If you are using a Spektrum™ transmitter, please refer to your transmitter's manual for detailed instructions on the range check process.

- 1. With the model resting on the ground, stand 30 paces (approximately 90 feet) away from the model.
- 2. Face the model with the transmitter in your normal flying position. Be sure the throttle is in the full down position and plug the flight battery into the speed control.
- 3. As you move the controls, watch to be sure the airplane's motor and controls operate smoothly. You should have total control of the model at 30 paces (90 feet).
- 4. If control issues exist, call the appropriate Horizon Product Support office (see addresses listed in the Warranty Services section of this manual) or go to [horizonhobby.com](http://horizonhobby.com) to find a local Spektrum distributor in your country for service when using a Spektrum radio system.

## Flying Your Model

Now that you have finished your F-4 Phantom 32 and it's ready to go, make one final check on a few things first. Is the main battery fully charged? Is the transmitter fully charged? Are the dual rates and travel adjustments set for the first flight? The F-4 Phantom 32 is very responsive and it is highly recommended that you take off with high rate, then switch to low rate right after takeoff. Check that the center of gravity has been verified and the timer has been set. We recommend that the timer be set for 3 minutes on the first flight. 3 minutes of flight will give you a good safety margin for a few landing approaches. The F-4 Phantom 32 will consistently give you 4+ minutes of high-speed flight. If you use power management, 6+ minutes is easily achieved.

Only fly this airplane at a sanctioned flying field, as it is not a parkflyer. Turn on the transmitter, plug in the flight battery, and turn on the switch for the radio. Check all control surfaces and basic motor operation. Check the motor at full throttle. Pick the model up and cycle the retracts. If everything is working properly, you are ready for flight.

Taxi the model onto the runway. Make a few taxi tests and get the nose gear steering adjusted so the model rolls straight down the runway. For your first flight leave, the flaps up on takeoff until you are familiar with its flying characteristics. Set the dual rates to the high position. If you have set the rudder and steering separately, you can also set the nose gear for a lower rate that is not linked to the control surface rates and can allow for a much smoother takeoff.

### Takeoff

While applying power, slowly steer with the rudder to keep the model straight. The airplane should accelerate quickly, and as the model gains flight speed, you will want to rotate when you feel comfortable. Generally, very slight back pressure on the elevator will allow the airplane to rotate smoothly at a comfortable, safe airspeed. The F-4 Phantom 32 will climb out at a nice angle of attack.

## Trimming and Flight Characteristics

After takeoff, gain some altitude, retract the landing gear and switch to low rates. Climb to a safe altitude and begin to trim the model. Once you have the model trimmed, you will want to get an idea of the flight quality with the flaps down and the model slowed down. Slow the model down to a little below half power and drop the flaps to the middle position. Check the trim again and also note if the model needs any up or down elevator compensation. At this time, you may also need to come back up on the power a little. Now try full flaps and note any other trim changes. The F-4 Phantom 32 will fly very nicely with full flaps and is very predictable in this configuration. Drop the landing gear and switch back to high rate to check the trim once again in landing configuration. Once you are happy with this, retract the gear, pull the flaps up, and switch back to low rate and start to enjoy the performance of the F-4 Phantom 32. You will find the model tracks very well through all aspects of flight. From high-speed passes, inverted flight, loops, and rolls, you will be flying like a true "jet jock" in no time. Get a feel for all rate settings. High rates are used mainly for takeoff and landings and low rates are for normal and precision flight.

## Landing

Remember to keep an eye on the radio timer. After 3 minutes on the first flight it's time to drop the flaps, retracts, switch to high rates and start shooting a few approaches with the F-4 Phantom 32. If you are landing in higher winds or cross winds use half flaps instead of full flaps as the airplane has a lot of drag. Adjust power to slow the plane down but keep flying speed. Don't be alarmed if you are flying at a much higher throttle setting than you are used to, ensure that you give the airplane what it needs to maintain enough airspeed to fly. As you roll onto final approach manage the power and begin to pull the nose up. The F-4 Phantom 32 has a very nice approach and decent rate. You will find that with the nose slightly high you can control the final approach descent with power management. The key to a great landing is to manage the power and elevator all the way to the ground and set down lightly on the main landing gear. After a few flights you will find the F-4 Phantom 32 can be set down lightly on the mains till it slows and gently settles the nose. We hope you enjoy flying the E-flite F-4 Phantom 32

Happy Landings!

## Daily Flight Checks

- 1. Check the battery voltage of the transmitter battery. Do not fly below the manufacturer's recommended voltage. To do so may cause your aircraft to crash.

### ***E-tips***

When you check these batteries, ensure you have the polarities correct on your expanded scale voltmeter.

- 2. Check all hardware (linkages, screws, nuts, and bolts) prior to each day's flight. Be sure that binding does not occur and that all parts are properly secured.
- 3. Ensure all surfaces are moving in the proper manner.
- 4. Perform a ground range check before each day's flying session.
- 5. Prior to starting your aircraft, turn off your transmitter, then turn it back on. Do this each time you start your aircraft. If any critical switches are on without your knowledge, the transmitter alarm will sound a warning.
- 6. Check that all trim levers are in the proper location.
- 7. All servo pigtails and switch harness plugs should be secured in the receiver. Make sure the switch harness moves freely in both directions.

## Limited Warranty

### WHAT THIS WARRANTY COVERS

Horizon Hobby, Inc. ("Horizon") warrants to the original purchaser that the product purchased (the "Product") will be free from defects in materials and workmanship at the date of purchase.

### WHAT IS NOT COVERED

This warranty is not transferable and does not cover (i) cosmetic damage, (ii) damage due to acts of God, accident, misuse, abuse, negligence, commercial use, or due to improper use, installation, operation or maintenance, (iii) modification of or to any part of the Product, (iv) attempted service by anyone other than a Horizon Hobby authorized service center, or (v) Products not purchased from an authorized Horizon dealer.

OTHER THAN THE EXPRESS WARRANTY ABOVE, HORIZON MAKES NO OTHER WARRANTY OR REPRESENTATION, AND HEREBY DISCLAIMS ANY AND ALL IMPLIED WARRANTIES, INCLUDING, WITHOUT LIMITATION, THE IMPLIED WARRANTIES OF NON-INFRINGEMENT, MERCHANTABILITY AND FITNESS FOR A PARTICULAR PURPOSE. THE PURCHASER ACKNOWLEDGES THAT THEY ALONE HAVE DETERMINED THAT THE PRODUCT WILL SUITABLY MEET THE REQUIREMENTS OF THE PURCHASER'S INTENDED USE.

### PURCHASER'S REMEDY

Horizon's sole obligation and purchaser's sole and exclusive remedy shall be that Horizon will, at its option, either (i) service, or (ii) replace, any Product determined by Horizon to be defective. Horizon reserves the right to inspect any and all Product(s) involved in a warranty claim. Service or replacement decisions are at the sole discretion of Horizon. Proof of purchase is required for all warranty claims. SERVICE OR REPLACEMENT AS PROVIDED UNDER THIS WARRANTY IS THE PURCHASER'S SOLE AND EXCLUSIVE REMEDY.

## LIMITATION OF LIABILITY

HORIZON SHALL NOT BE LIABLE FOR SPECIAL, INDIRECT, INCIDENTAL OR CONSEQUENTIAL DAMAGES, LOSS OF PROFITS OR PRODUCTION OR COMMERCIAL LOSS IN ANY WAY, REGARDLESS OF WHETHER SUCH CLAIM IS BASED IN CONTRACT, WARRANTY, TORT, NEGLIGENCE, STRICT LIABILITY OR ANY OTHER THEORY OF LIABILITY, EVEN IF HORIZON HAS BEEN ADVISED OF THE POSSIBILITY OF SUCH DAMAGES. Further, in no event shall the liability of Horizon exceed the individual price of the Product on which liability is asserted. As Horizon has no control over use, setup, final assembly, modification or misuse, no liability shall be assumed nor accepted for any resulting damage or injury. By the act of use, setup or assembly, the user accepts all resulting liability. If you as the purchaser or user are not prepared to accept the liability associated with the use of the Product, purchaser is advised to return the Product immediately in new and unused condition to the place of purchase.

## LAW

These terms are governed by Illinois law (without regard to conflict of law principals). This warranty gives you specific legal rights, and you may also have other rights which vary from state to state. Horizon reserves the right to change or modify this warranty at any time without notice.

## Warranty Services

### QUESTIONS, ASSISTANCE, AND SERVICES

Your local hobby store and/or place of purchase cannot provide warranty support or service. Once assembly, setup or use of the Product has been started, you must contact Horizon directly. This will enable Horizon to better answer your questions and service you in the event that you may need any assistance. For questions or assistance, please direct your email to [productsupport@horizonhobby.com](mailto:productsupport@horizonhobby.com), or call 877.504.0233 toll free to speak to a Product Support representative. You may also find information on our website at [www.horizonhobby.com](http://www.horizonhobby.com).

### INSPECTION OR SERVICES

If this Product needs to be inspected or serviced, please use the Horizon Online Service Request submission process found on our website or call Horizon to obtain a Return Merchandise Authorization (RMA) number. Pack the Product securely using a shipping carton. Please note that original boxes may be included, but are not designed to withstand the rigors of shipping without additional protection. Ship via a carrier that provides tracking and insurance for lost or damaged parcels, as Horizon is not responsible for merchandise until it arrives and is accepted at our facility. An Online Service Request is available at <http://www.horizonhobby.com> under the Support tab. If you do not have internet access, please contact Horizon Product Support to obtain a RMA number along with instructions for submitting your product for service. When calling Horizon, you will be asked to provide your complete name, street address, email address and phone number where you can be reached during business hours. When sending product into Horizon, please include your RMA number, a list of the included items, and a brief summary of the problem. A copy of your original sales receipt must be included for warranty consideration. Be sure your name, address, and RMA number are clearly written on the outside of the shipping carton.

**Notice: Do not ship LiPo batteries to Horizon. If you have any issue with a LiPo battery, please contact the appropriate Horizon Product Support office.**

## WARRANTY REQUIREMENTS

**For Warranty consideration, you must include your original sales receipt verifying the proof-of-purchase date.** Provided warranty conditions have been met, your Product will be serviced or replaced free of charge. Service or replacement decisions are at the sole discretion of Horizon.

### NON-WARRANTY SERVICE

**Should your service not be covered by warranty service will be completed and payment will be required without notification or estimate of the expense unless the expense exceeds 50% of the retail purchase cost.** By submitting the item for service you are agreeing to payment of the service without notification. Service estimates are available upon request. You must include this request with your item submitted for service. Non-warranty service estimates will be billed a minimum of ½ hour of labor. In addition you will be billed for return freight. Horizon accepts money orders and cashiers checks, as well as Visa, MasterCard, American Express, and Discover cards. By submitting any item to Horizon for service, you are agreeing to Horizon's Terms and Conditions found on our website <http://www.horizonhobby.com/Service/Request/>.

### UNITED STATES

*(Electronics and engines)*

Horizon Service Center  
4105 Fieldstone Rd  
Champaign, Illinois  
61822 USA  
[productsupport@horizonhobby.com](mailto:productsupport@horizonhobby.com)  
877-504-0233  
Online Repair Request visit:  
[www.horizonhobby.com/service](http://www.horizonhobby.com/service)

*(All other products)*

Horizon Product Support  
4105 Fieldstone Rd  
Champaign, Illinois  
61822 USA  
[productsupport@horizonhobby.com](mailto:productsupport@horizonhobby.com)  
877-504-0233



## UNITED KINGDOM

Horizon Hobby Limited  
Units 1-4 Ployters Rd  
Staple Tye  
Harlow, Essex  
CM18 7NS  
United Kingdom  
sales@horizonhobby.co.uk  
+44 (0) 1279 641 097

## GERMANY

Horizon Technischer Service  
Christian-Junge-Straße 1  
25337 Elmshorn, Germany  
service@horizonhobby.de  
+49 4121 46199 66

## FRANCE

Horizon Hobby SAS  
14 Rue Gustave Eiffel  
Zone d'Activité du Réveil Matin  
91230 Montgeron  
+33 (0) 1 60 47 44 70

## Compliance Information for the European Union



### INSTRUCTIONS FOR DISPOSAL OF WEEE BY USERS IN THE EUROPEAN UNION

This product must not be disposed of with other waste. Instead, it is the user's responsibility to dispose of their waste equipment by handing it over to a designated collection point for the recycling of waste electrical and electronic equipment. The separate collection and recycling of your waste equipment at the time of disposal will help to conserve natural resources and ensure that it is recycled in a manner that protects human health and the environment. For more information about where you can drop off your waste equipment for recycling, please contact your local city office, your household waste disposal service or where you purchased the product.

## Academy of Model Aeronautics National Model Aircraft Safety Code

Effective January 1, 2011

### A. GENERAL

A model aircraft is a non-human-carrying aircraft capable of sustained flight in the atmosphere. It may not exceed limitations of this code and is intended exclusively for sport, recreation and/or competition. All model flights must be conducted in accordance with this safety code and any additional rules specific to the flying site.

1. Model aircraft will not be flown:
  - (a) In a careless or reckless manner.
  - (b) At a location where model aircraft activities are prohibited.
2. Model aircraft pilots will:
  - (a) Yield the right of way to all man carrying aircraft.
  - b) See and avoid all aircraft and a spotter must be used when appropriate. (AMA Document #540-D-See and Avoid Guidance.)
  - (c) Not fly higher than approximately 400 feet above ground level within three (3) miles of an airport, without notifying the airport operator.
  - (d) Not interfere with operations and traffic patterns at any airport, heliport or seaplane base except where there is a mixed use agreement.
  - (e) Not exceed a takeoff weight, including fuel, of 55 pounds unless in compliance with the AMA Large Model Aircraft program. (AMA Document 520-A)
  - (f) Ensure the aircraft is identified with the name and address or AMA number of the owner on the inside or affixed to the outside of the model aircraft. (This does not apply to model aircraft flown indoors).
  - (g) Not operate aircraft with metal-blade propellers or with gaseous boosts except for helicopters operated under the provisions of AMA Document #555.
  - (h) Not operate model aircraft while under the influence of alcohol or while using any drug which could adversely affect the pilot's ability to safely control the model.

(i) Not operate model aircraft carrying pyrotechnic devices which explode or burn, or any device which propels a projectile or drops any object that creates a hazard to persons or property.

Exceptions:

- Free Flight fuses or devices that burn producing smoke and are securely attached to the model aircraft during flight.
- Rocket motors (using solid propellant) up to a G-series size may be used provided they remain attached to the model during flight. Model rockets may be flown in accordance with the National Model Rocketry Safety Code but may not be launched from model aircraft.
- Officially designated AMA Air Show Teams (AST) are authorized to use devices and practices as defined within the Team AMA Program Document (AMA Document #718).  
(j) Not operate a turbine-powered aircraft, unless in compliance with the AMA turbine regulations. (AMA Document #510-A).

3. Model aircraft will not be flown in AMA sanctioned events, air shows or model demonstrations unless:
  - (a) The aircraft, control system and pilot skills have successfully demonstrated all maneuvers intended or anticipated prior to the specific event.
  - (b) An inexperienced pilot is assisted by an experienced pilot.
4. When and where required by rule, helmets must be properly worn and fastened. They must be OSHA, DOT, ANSI, SNELL or NOCSAE approved or comply with comparable standards.

### **B. RADIO CONTROL (RC)**

1. All pilots shall avoid flying directly over unprotected people, vessels, vehicles or structures and shall avoid endangerment of life and property of others.
2. A successful radio equipment ground-range check in accordance with manufacturer's recommendations will be completed before the first flight of a new or repaired model aircraft.

3. At all flying sites a safety line(s) must be established in front of which all flying takes place (AMA Document #706-Recommended Field Layout):
  - (a) Only personnel associated with flying the model aircraft are allowed at or in front of the safety line.
  - (b) At air shows or demonstrations, a straight safety line must be established.
  - (c) An area away from the safety line must be maintained for spectators.
  - (d) Intentional flying behind the safety line is prohibited.
4. RC model aircraft must use the radio-control frequencies currently allowed by the Federal Communications Commission (FCC). Only individuals properly licensed by the FCC are authorized to operate equipment on Amateur Band frequencies.
5. RC model aircraft will not operate within three (3) miles of any pre-existing flying site without a frequency-management agreement (AMA Documents #922- Testing for RF Interference; #923- Frequency Management Agreement)
6. With the exception of events flown under official AMA Competition Regulations, excluding takeoff and landing, no powered model may be flown outdoors closer than 25 feet to any individual, except for the pilot and the pilot's helper(s) located at the flight line.
7. Under no circumstances may a pilot or other person touch a model aircraft in flight while it is still under power, except to divert it from striking an individual. This does not apply to model aircraft flown indoors.
8. RC night flying requires a lighting system providing the pilot with a clear view of the model's attitude and orientation at all times.
9. The pilot of a RC model aircraft shall:
  - (a) Maintain control during the entire flight, maintaining visual contact without enhancement other than by corrective lenses prescribed for the pilot.
  - (b) Fly using the assistance of a camera or First-Person View (FPV) only in accordance with the procedures outlined in AMA Document #550.

### **C. FREE FLIGHT**

1. Must be at least 100 feet downwind of spectators and automobile parking when the model aircraft is launched.
2. Launch area must be clear of all individuals except mechanics, officials, and other fliers.
3. An effective device will be used to extinguish any fuse on the model aircraft after the fuse has completed its function.

### **D. CONTROL LINE**

1. The complete control system (including the safety thong where applicable) must have an inspection and pull test prior to flying.
2. The pull test will be in accordance with the current Competition Regulations for the applicable model aircraft category.
3. Model aircraft not fitting a specific category shall use those pull-test requirements as indicated for Control Line Precision Aerobatics.
4. The flying area must be clear of all utility wires or poles and a model aircraft will not be flown closer than 50 feet to any above-ground electric utility lines.
5. The flying area must be clear of all nonessential participants and spectators before the engine is started.

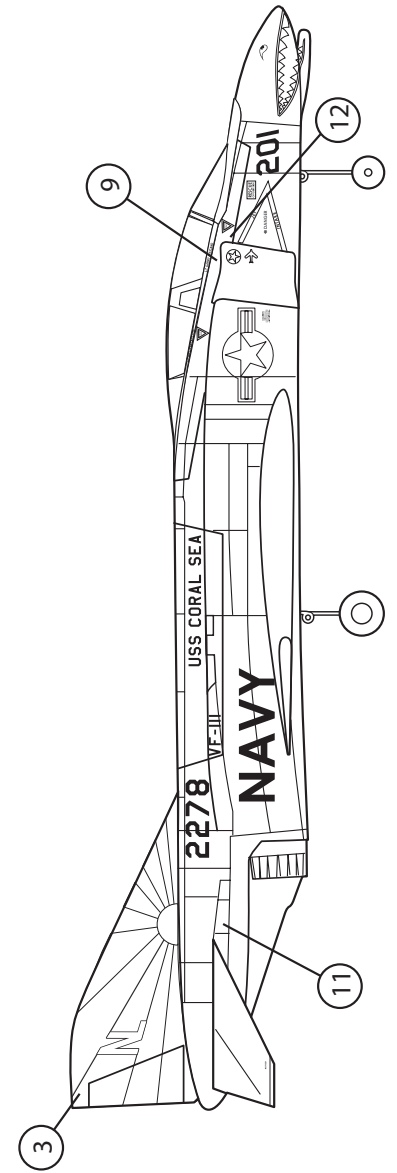
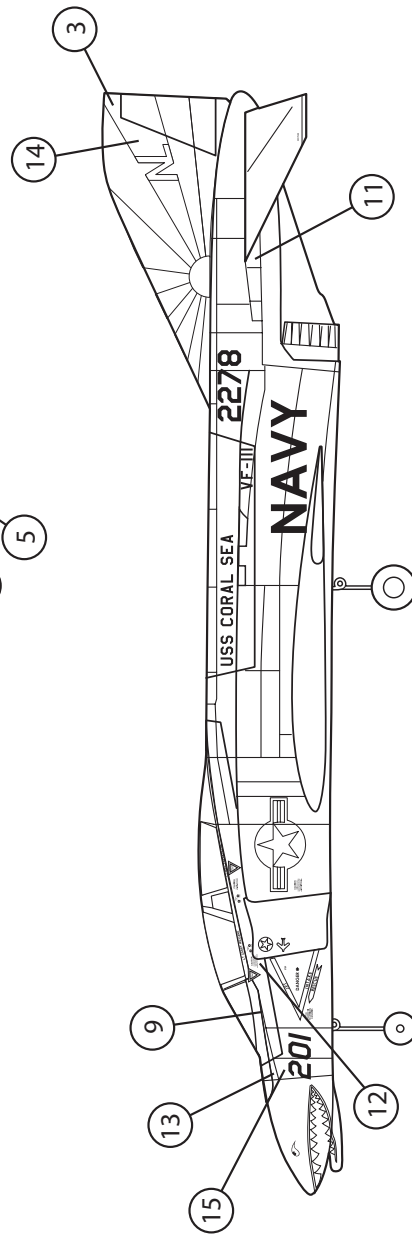
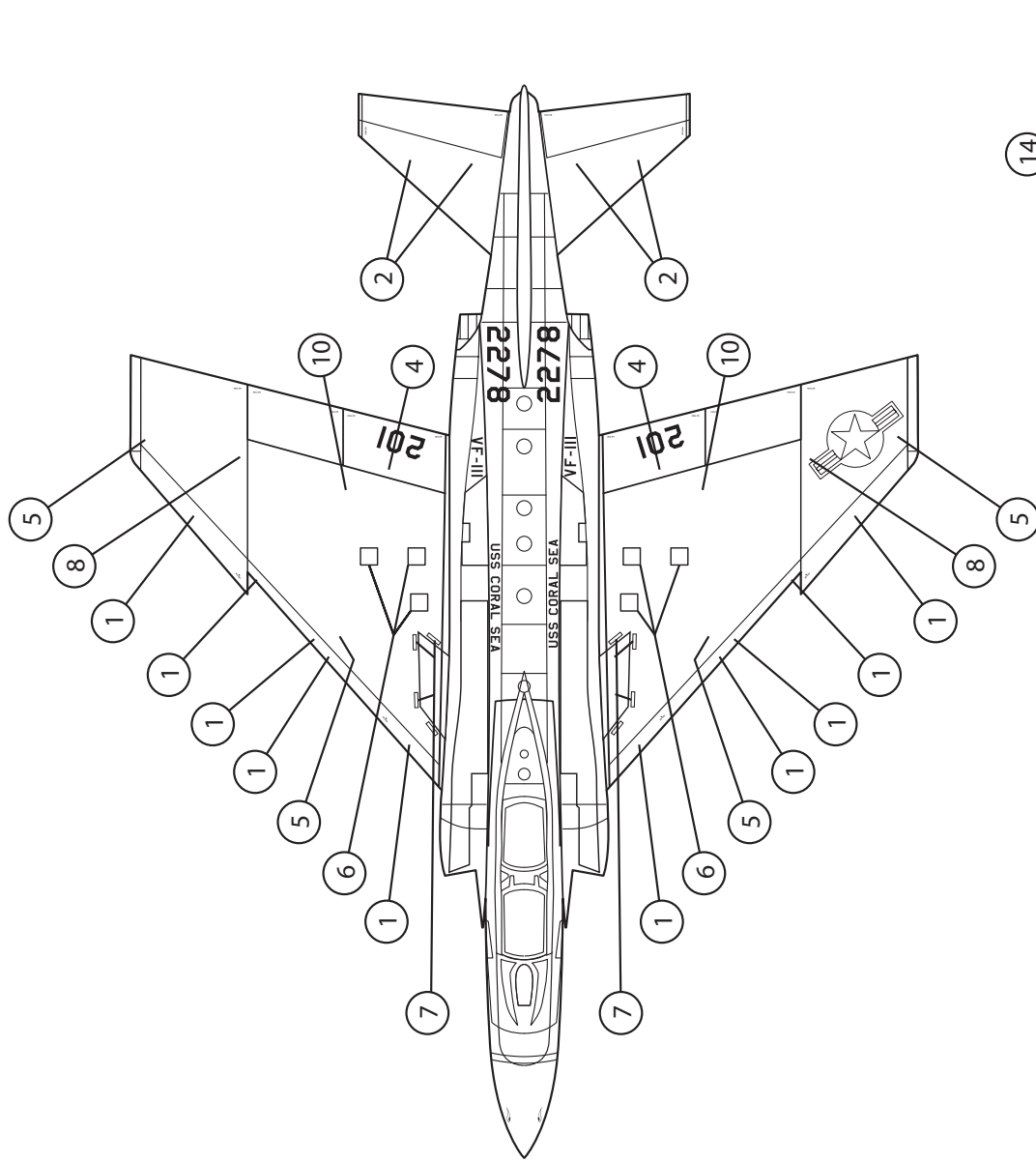



© 2011 Horizon Hobby, Inc.  
horizonhobby.com  
www.e-fliterc.com

*E-flite, Delta-V, DSM2, DSMX, Celectra, UltraCote, JR and the Horizon Hobby logo are trademarks or registered trademarks of Horizon Hobby, Inc.*

*The Spektrum trademark is used with permission of Bachmann Industries, Inc.*

*All other trademarks, service marks and logos are the property of their respective owners.*