

BLADETM CX²



Specifications

Length	16.42 in (417mm)
Height	7.17 in (182mm)
Main Rotor Diameter	13.60 in (345mm)
Weight RTF w/Battery	8.0 oz (227 g)
Main Motor	180 (2 installed)
Battery	7.4V 800mAh Li-Po (included)
Transmitter	2.4GHz DSM 5-Channel (included)
On-Board Electronics	4-in-1 Receiver/Mixer/ESC/Gyro (installed)
Servos	S60 Super Sub-Micro (2 installed)

Table of Contents

Specifications.....	1
Introduction.....	3
Warning.....	3
Note on Lithium Polymer Batteries.....	3
Warranty Period.....	3
Limited Warranty.....	3
Damage Limits.....	4
Safety Precautions.....	4
Questions, Assistance and Repairs.....	4
Inspections or Repairs.....	4
Warranty Inspection and Repairs.....	4
Non-Warranty Repairs.....	5
Additional Safety Precautions and Warnings.....	5
FCC Information.....	6
Additional Required Equipment.....	6
Blade CX2 RTF Contents.....	6
Preparing for the First Flight Checklist.....	7
Flying Checklist.....	7
Battery Warnings and Guidelines.....	8
Battery Charging.....	10
Charge Errors and Indications.....	13
Installing the Transmitter Batteries.....	13
Installing the Flight Battery.....	14
Center of Gravity.....	15
Control Test.....	16
4-in-1 Control Unit Description, Arming and Motor Control Test.....	20
Installing the Optional Training Gear.....	23
Understanding the Controls.....	26
Choosing a Flying Area.....	30
Flying the Blade CX2.....	30
Main Motor Proportional Mix Trimmer Pot Description and Adjustment.....	32
Gyro Gain Trimmer Pot Description and Adjustment.....	34
Upper Main Rotor Blade Tracking Adjustment.....	35
Channel 5 Knob Description and Function.....	37
Transmitter and 4-in-1 Control Unit Receiver Binding and Fail-Safe.....	39
Main Motor Care and Installing the Optional Main Motor Heat Sink.....	41
2006 Official AMA National Model Aircraft Safety Code.....	43
Replacement Parts List.....	44
Optional Parts List.....	44
Replacement and Optional Parts.....	45
Exploded View Parts Listing.....	46
Exploded View.....	47

Introduction

The Blade™ CX2 takes the beginner-friendly flight stability of the original Blade CX and adds Spektrum® 2.4GHz DSM® radio control that lets you fly anywhere, anytime without ever having to worry about interference. In fact, it's the first ready-to-fly RC aircraft of any kind to come with this extraordinary technology built in.

And best of all, the Blade CX2 is a truly Ready-for-Anyone-to-Fly micro class electric helicopter. Its coaxial counter-rotating blades cancel out the rotational torque that makes hovering a conventional helicopter so difficult while providing unsurpassed stability in all other phases of flight too. And whether you are a first-time helicopter pilot or an experienced pilot looking for the best in coaxial micro helicopter performance, you'll enjoy many of the outstanding features that have the Blade CX2 flying in no time such as factory installed main motors, 4-in-1 control unit with receiver, mixer, ESCs and gyro, and S60 Super Sub-Micro Servos. With the included 5-channel transmitter, 2-cell 800mAh Li-Po battery pack, DC charger and AC adapter, you'll have precise control for hovering, forward flight and more with durations of up to 10–15 minutes per charge.

While the Blade CX2 is nearly ready-to-fly right from the box, please take the time to read through this manual completely for tips on battery safety and charging, control checks, flying and more. Please also take a few minutes to watch the included Instructional Video CD for additional tips and to see the Blade CX2 in action.

Warning

An RC helicopter is not a toy! If misused, it can cause serious bodily harm and damage to property. Fly only in open areas, preferably at AMA (Academy of Model Aeronautics) approved flying sites, following all instructions.

Keep loose items that can get entangled in the rotor blades away from the main and tail blades, including loose clothing, or other objects such as pencils and screwdrivers. Especially keep your hands away from the rotor blades.

Note on Lithium Polymer Batteries



Lithium Polymer batteries are significantly more volatile than alkaline or Ni-Cd/Ni-MH batteries used in RC applications. All manufacturer's instructions and warnings must be followed closely. Mishandling of Li-Po batteries can result in fire. Always follow the manufacturer's instructions when disposing of Lithium Polymer batteries.

Warranty Period

Horizon Hobby, Inc., (Horizon) warrants that the Products purchased (the "Product") will be free from defects in materials and workmanship at the date of purchase by the Purchaser.

Limited Warranty

(a) This warranty is limited to the original Purchaser ("Purchaser") and is not transferable. REPAIR OR REPLACEMENT AS PROVIDED UNDER THIS WARRANTY IS THE EXCLUSIVE REMEDY OF THE PURCHASER. This warranty covers only those Products purchased from an authorized Horizon dealer. Third party transactions are not covered by this warranty. Proof of purchase is required for warranty claims. Further, Horizon reserves the right to change or modify this warranty without notice and disclaims all other warranties, express or implied.

(b) Limitations- HORIZON MAKES NO WARRANTY OR REPRESENTATION, EXPRESS OR IMPLIED, ABOUT NON-INFRINGEMENT, MERCHANTABILITY OR FITNESS FOR A PARTICULAR PURPOSE OF THE PRODUCT. THE PURCHASER ACKNOWLEDGES THAT THEY ALONE HAVE DETERMINED THAT THE PRODUCT WILL SUITABLY MEET THE REQUIREMENTS OF THE PURCHASER'S INTENDED USE.

(c) Purchaser Remedy- Horizon's sole obligation hereunder shall be that Horizon will, at its option, (i) repair or (ii) replace, any Product determined by Horizon to be defective. In the event of a defect, these are the Purchaser's exclusive remedies. Horizon reserves the right to inspect any and all equipment involved in a warranty claim. Repair or replacement decisions are at the sole discretion of Horizon. This warranty does not cover cosmetic damage or damage due to acts of God, accident, misuse, abuse, negligence, commercial use, or modification of or to any part of the Product. This warranty does not cover damage due to improper installation, operation, maintenance, or attempted repair by anyone other than Horizon. Return of any goods by Purchaser must be approved by Horizon before shipment.

Damage Limits

HORIZON SHALL NOT BE LIABLE FOR SPECIAL, INDIRECT OR CONSEQUENTIAL DAMAGES, LOSS OF PROFITS OR PRODUCTION OR COMMERCIAL LOSS IN ANY WAY CONNECTED WITH THE PRODUCT, WHETHER SUCH CLAIM IS BASED IN CONTRACT, WARRANTY, NEGLIGENCE, OR STRICT LIABILITY. Further, in no event shall the liability of Horizon exceed the individual price of the Product on which liability is asserted. As Horizon has no control over use, setup, final assembly, modification or misuse, no liability shall be assumed nor accepted for any resulting damage or injury. By the act of use, setup or assembly, the user accepts all resulting liability.

If you as the Purchaser or user are not prepared to accept the liability associated with the use of this Product, you are advised to return this Product immediately in new and unused condition to the place of purchase.

Law: These Terms are governed by Illinois law (without regard to conflict of law principals).

Safety Precautions

This is a sophisticated hobby Product and not a toy. It must be operated with caution and common sense and requires some basic mechanical ability. Failure to operate this Product in a safe and responsible manner could result in injury or damage to the Product or other property. This Product is not intended for use by children without direct adult supervision. The Product manual contains instructions for safety, operation and maintenance. It is essential to read and follow all the instructions and warnings in the manual, prior to assembly, setup or use, in order to operate correctly and avoid damage or injury.

Questions, Assistance and Repairs

Your local hobby store and/or place of purchase cannot provide warranty support or repair. Once assembly, setup or use of the Product has been started, you must contact Horizon directly. This will enable Horizon to better answer your questions and service you in the event that you may need any assistance. For questions or assistance, please direct your email to productsupport@horizonhobby.com, or call 877.504.0233 toll free to speak to a service technician.

Inspections or Repairs

If this Product needs to be inspected or repaired, please call for a Return Merchandise Authorization (RMA). Pack the Product securely using a shipping carton. Please note that original boxes may be included, but are not designed to withstand the rigors of shipping without additional protection. Ship via a carrier that provides tracking and insurance for lost or damaged parcels, as **Horizon is not responsible for merchandise until it arrives and is accepted at our facility**. A Service Repair Request is available at www.horizonhobby.com on the "Support" tab. If you do not have internet access, please include a letter with your complete name, street address, email address and phone number where you can be reached during business days, your RMA number, a list of the included items, method of payment for any non-warranty expenses and a brief summary of the problem. Your original sales receipt must also be included for warranty consideration. Be sure your name, address, and RMA number are clearly written on the outside of the shipping carton.

Warranty Inspection and Repairs

To receive warranty service, you must include your original sales receipt verifying the proof-of-purchase date. Provided warranty conditions have been met, your Product will be repaired or replaced free of charge. Repair or replacement decisions are at the sole discretion of Horizon Hobby.

Non-Warranty Repairs

Should your repair not be covered by warranty the repair will be completed and payment will be required without notification or estimate of the expense unless the expense exceeds 50% of the retail purchase cost. By submitting the item for repair you are agreeing to payment of the repair without notification. Repair estimates are available upon request. You must include this request with your repair. Non-warranty repair estimates will be billed a minimum of ½ hour of labor. In addition you will be billed for return freight. Please advise us of your preferred method of payment. Horizon accepts money orders and cashiers checks, as well as Visa, MasterCard, American Express, and Discover cards. If you choose to pay by credit card, please include your credit card number and expiration date. Any repair left unpaid or unclaimed after 90 days will be considered abandoned and will be disposed of accordingly. **Please note: Non-warranty repair is only available on electronics and model engines.**

Electronics and engines requiring inspection or repair should be shipped to the following address:

Horizon Service Center
4105 Fieldstone Road
Champaign, Illinois 61822

All other Products requiring warranty inspection or repair should be shipped to the following address:

Horizon Product Support
4105 Fieldstone Road
Champaign, Illinois 61822

Please call 877-504-0233 with any questions or concerns regarding this Product or warranty.

Additional Safety Precautions and Warnings

As the user of this product, you are solely responsible for operating it in a manner that does not endanger yourself and others or result in damage to the product or the property of others.

This model is controlled by a radio signal that is subject to interference from many sources outside your control. This interference can cause momentary loss of control so it is advisable to always keep a safe distance in all directions around your model, as this margin will help to avoid collisions or injury.

- Never operate your model with low transmitter batteries.
- Always operate your model in an open area away from cars, traffic, or people.
- Avoid operating your model in the street where injury or damage can occur.
- Never operate the model out into the street or populated areas for any reason.
- Carefully follow the directions and warnings for this and any optional support equipment (chargers, rechargeable battery packs, etc.) that you use.
- Keep all chemicals, small parts and anything electrical out of the reach of children.
- Moisture causes damage to electronics. Avoid water exposure to all equipment not specifically designed and protected for this purpose.
- Never lick or place any portion of your model in your mouth as it could cause serious injury or even death.

FCC Information

This device complies with part 15 of the FCC rules. Operation is subject to the following two conditions: (1) This device may not cause harmful interference, and (2) this device must accept any interference received, including interference that may cause undesired operation.

Caution: Changes or modifications not expressly approved by the party responsible for compliance could void the user's authority to operate the equipment.

This product contains a radio transmitter with wireless technology which has been tested and found to be compliant with the applicable regulations governing a radio transmitter in the 2.400 GHz to 2.4835 GHz frequency range.

The associated regulatory agencies of the following countries recognize the noted certifications for this product as authorized for sale and use:

USA	Canada	Belgium
Denmark	France	Finland
Germany	Italy	Netherlands
Spain	Sweden	UK

Additional Required Equipment

No additional equipment is required to complete your Blade™ CX2.

Blade CX2 RTF Contents

Item	Description
Not Available Separately	Blade CX2 RTF Airframe
EFLH1055	LP5DSM 5-Channel Transmitter, 2.4GHz
EFLB0990	7.4V 800mAh 2-Cell Li-Po, JST/Balance
EFLC3110	2- to 3-Cell Li-Po Balancing Charger, 0.65A
EFLC4000	AC to 12V DC, 1.5-Amp Power Supply
EFLH1209	Mounting Accessories & Screwdriver
EFLH1022	Bind Plug



Preparing for the First Flight Checklist

Please note this checklist is not intended to be a replacement for the content included in this instruction manual. Although it can be used as a quick start guide, we strongly suggest reading through this manual completely before proceeding.

- Remove and inspect contents
- Charge the flight battery
- Install the 4 included "AA" batteries in the transmitter
- Install the flight battery in the helicopter (once it has been fully charged)
- Check the center of gravity of the helicopter
- Test the controls
- Install the optional Training Gear Set (EFLH1205; strongly recommended if this is your first helicopter model)
- Familiarize yourself with the controls
- Find a suitable area for flying

Flying Checklist

Please note this checklist is not intended to be a replacement for the content included in this instruction manual. Although it can be used as a quick start guide, we strongly suggest reading through this manual completely before proceeding.

- Always turn the transmitter on first
- Plug the flight battery into the 4-in-1 control unit
- Allow the 4-in-1 control unit to arm properly
- Fly the model
- Land the model
- Unplug the flight battery from the 4-in-1 control unit
- Always turn the transmitter off last

Battery Warnings and Guidelines



While the 7.4V 800mAh 2-cell Lithium Polymer Battery Pack (EFLB0990) included with your Blade™ CX2 features Charge Protection Circuitry and Balance Charging via the included 2- to 3-Cell Lithium Polymer Balancing Charger (EFLC3110) to help ensure a safe charge every time, you **MUST** read the following safety instructions and warnings before handling, charging or using the Li-Po battery pack.

Note: Lithium Polymer batteries are significantly more volatile than the alkaline, Ni-Cd or Ni-MH batteries used in RC applications. All instructions and warnings must be followed exactly. Mishandling of Li-Po batteries can result in fire.

By handling, charging or using the included Li-Po battery you assume all risks associated with lithium batteries. If you do not agree with these conditions, return your complete Blade CX2 model in new, unused condition to the place of purchase immediately.

- You must charge the included 7.4V 800mAh 2-cell Li-Po battery pack in a safe area away from flammable materials.
- Do not charge the battery when installed in the helicopter.
- Never charge the battery unattended. When charging the battery you should always remain in constant observation to monitor the charging process and react to potential problems that may occur.
- After flight, the battery must be cooled to ambient temperature before charging.
- **You MUST use the included 2- to 3-Cell 7.4-11.1V Li-Po Balancing Charger ONLY.** Failure to do so may result in a fire causing personal injury and/or property damage. **DO NOT use a Ni-Cd or Ni-MH charger.**



- **If at any time during the charge or discharge process the battery begins to balloon or swell, discontinue charging or discharging immediately. Quickly and safely disconnect the battery, then place it in a safe, open area away from flammable materials to observe it for at least 15 minutes. Continuing to charge or discharge a battery that has begun to balloon or swell can result in a fire. A battery that has ballooned or swollen even a small amount must be removed from service completely.**
- In the event of a crash, you must quickly and safely disconnect and remove the battery from the model, then place it in a safe, open area away from flammable materials to observe it for at least 15 minutes.
- Store the battery at room temperature and approximately ½ charge (3.8V per cell; 7.6V for a 2-cell battery pack) for best results.
- When transporting or temporarily storing the battery, the temperature range should be from 40–120 degrees Fahrenheit. Do not store the battery or model in a car or direct sunlight whenever possible. If stored in a hot car, the battery can be damaged or even cause a fire.
- **Do not over-discharge the battery. Discharging the battery too low can cause damage to the pack resulting in reduced performance and duration.**

Li-Po cells should not be discharged to below 3V each under load. In the case of the 2-cell Li-Po packs used for the Blade™ CX2, you will not want to allow the battery to fall to below 6V during flight.

The Blade CX2 4-in-1 control unit does not feature a voltage cutoff of any type, so we suggest that you be extremely aware of the power level of the Li-Po battery pack during flight. If at any time the helicopter begins to require more throttle than typical to maintain hover or flight, or has lost significant power, you must land the helicopter and power the motors down IMMEDIATELY to prevent over-discharge of the Li-Po battery pack. If you continue to run the motors after noticing a loss in power, it is possible to discharge the Li-Po battery pack too far, causing permanent damage to the pack.

Over-discharge of the Li-Po battery pack can result in shortened flight times, loss of power output or failure of the pack entirely.

If you have any further questions or concerns regarding the handling, charging and/or use of the included Li-Po battery pack, please contact Horizon Hobby's Product Support staff at 877-504-0233.

Battery Charging

It is important that you only charge the included 7.4V 800mAh 2-cell Li-Po Battery Pack (EFLB0990) with the included 2- to 3-Cell 7.4-11.1V Li-Po Balancing Charger (EFLC3110). Your battery pack is equipped with special Charge Protection Circuitry and a Balance Charge Lead with connector that is only compatible with this charger. Attempting to charge the pack using another Li-Po charger or non Li-Po compatible charger could result in serious damage. Please familiarize yourself thoroughly with the warnings and guidelines (pages 8–9) before continuing.

The included 2- to 3-Cell 7.4-11.1V Li-Po Balancing Charger will charge a near fully discharged (not over-discharged) 7.4V 800mAh 2-cell Li-Po Battery Pack in approximately 1.2–1.5 hours. In some cases the charge time may be shorter depending on the actual amount of capacity left in the pack after a flight. **NEVER charge the battery unattended.**

Note: The Li-Po battery pack included with your Blade™ CX2 will arrive partially charged. For this reason the initial charge may only take approximately 30–50 minutes.

The charger requires up to 1.5 amps of 11.5- to 15-Volt DC input power that can be supplied by the included AC to 12V DC, 1.5-Amp Power Supply (EFLC4000) for convenient charging anywhere an AC outlet is available. **NEVER attempt to power the charger from an AC outlet without the use of a proper AC to DC adapter/power supply.**

Note: When using the AC to DC adapter/power supply, the charger is protected to prevent damage if the alligator clips touch. However, please take care to ensure that the alligator clips do not cause shorting of the battery, adapter/power supply, etc. by keeping them clear.



Input power for the charger can also be supplied from a small 12V gel cell or car battery.



The charger is equipped with two LED indicators marked RED and GREEN on the label. These LEDs indicate the following (also found on the label of the charger):

- **Red Flashing LED Only:** Input power with no battery connected
- **Red and Green Solid LED:** Battery connected and charging
- **Red Solid LED Only:** Charge complete
- **Red and Green Flashing LED:** Charge error

Once you have connected the charger to a power source (Use care to ensure proper polarity when connecting the charger to the power source), its red LED will flash to indicate the charger has power and is ready to begin charging. Connect the Li-Po battery pack to the charger using the specially marked Balance Charge Lead exiting the battery pack and the connector labeled with 7.4V on the charger. The connector is keyed to prevent reverse polarity connection.

Note: Do not force the connector on the Balance Charge Lead into the connector labeled 11.1V on the charger. Doing so could result in damage to the battery pack and charger, and could result in a fire.



When the battery is properly connected and charging normally, the red and green LED indicators will glow solid. Once the battery has been fully charged, the green LED will go out, leaving just the red LED glowing solid. The battery can now be removed from the charger and installed into the Blade™ CX2 for flight.

Charge Errors and Indications

In the event that both the red and green LEDs flash, a charge error has occurred. Some examples of charge errors and their indications include:

- Alternating flashing of the red and green LEDs will indicate that the charge process has been interrupted. If input power to the charger has been interrupted due to disconnection from the power source or a drop in voltage/current output from the power source, unplug the battery from the charger. Next, check to make sure that the input power plug from the AC to 12V DC adapter/power supply is connected or that the alligator clips are firmly and properly attached to the power source. Also be sure that the power source is providing the proper amount of voltage and current required to the charger.

After confirming the connections and that the power source is delivering the necessary voltage and current, restart the charge process by connecting the battery pack. Continue to monitor the charge process to ensure that no further charge errors occur.

- Simultaneous flashing of the red and green LEDs will indicate that the voltage of the Li-Po battery pack is too low to allow the charge process to begin. In this case the battery may have been over-discharged due to flying the model too long (For more information on preventing over-discharge of the Li-Po battery pack, see the guidelines section found on page 9), or that a single cell or even all cells in the battery pack may be damaged.

If after several charging attempts you continue to see this charge error indication, you should remove the battery pack from service and replace it with a new one.

If you have any further questions or concerns regarding charge error indications, please contact Horizon Hobby's Product Support staff at 877-504-0233.

Installing the Transmitter Batteries

Install the 4 included "AA" batteries in the transmitter. Check the power level of the batteries and operation of the transmitter by switching the power switch on (upward). The LCD screen at the top of the transmitter will indicate the power level of the batteries. If at any time the voltage indicated on the LCD screen falls to 4.5V or less, an alarm will sound, and it will be necessary to replace the batteries with new ones.

Note: Because the LP5DSM transmitter included with the Blade CX2 is equipped with Spektrum 2.4GHz DSM technology, it does not require the same input voltage or current consumption as a typical 72MHz transmitter for proper operation and optimum performance.



Installing the Flight Battery

Use the included hook and loop material for mounting the Li-Po battery pack. The “hook” material is already installed on the battery frame stop. The included “loop” material can be installed on the end of the battery with or without the wire leads, depending on how you choose to install the battery and route the wire leads.

If you choose to install the loop material on the end of the battery with the wire leads, it will be a little more difficult to install the battery in the model but the wire leads can be tucked neatly inside of the body.

If you choose to install the loop material on the end of the battery without the wire leads, it will be easier to install the battery in the model but the power leads (red and black leads with red JST connector) will need to be placed outside of the body.



The battery can be installed through the opening in the rear of the body. Be sure to install the end of the battery with the loop material first. If you have installed the loop material on the end of the battery with the wire leads, be sure that the wire leads are oriented to the left side of the model so that they can pass by the stop. Slide the battery into the support frame until the hook and loop material makes contact.

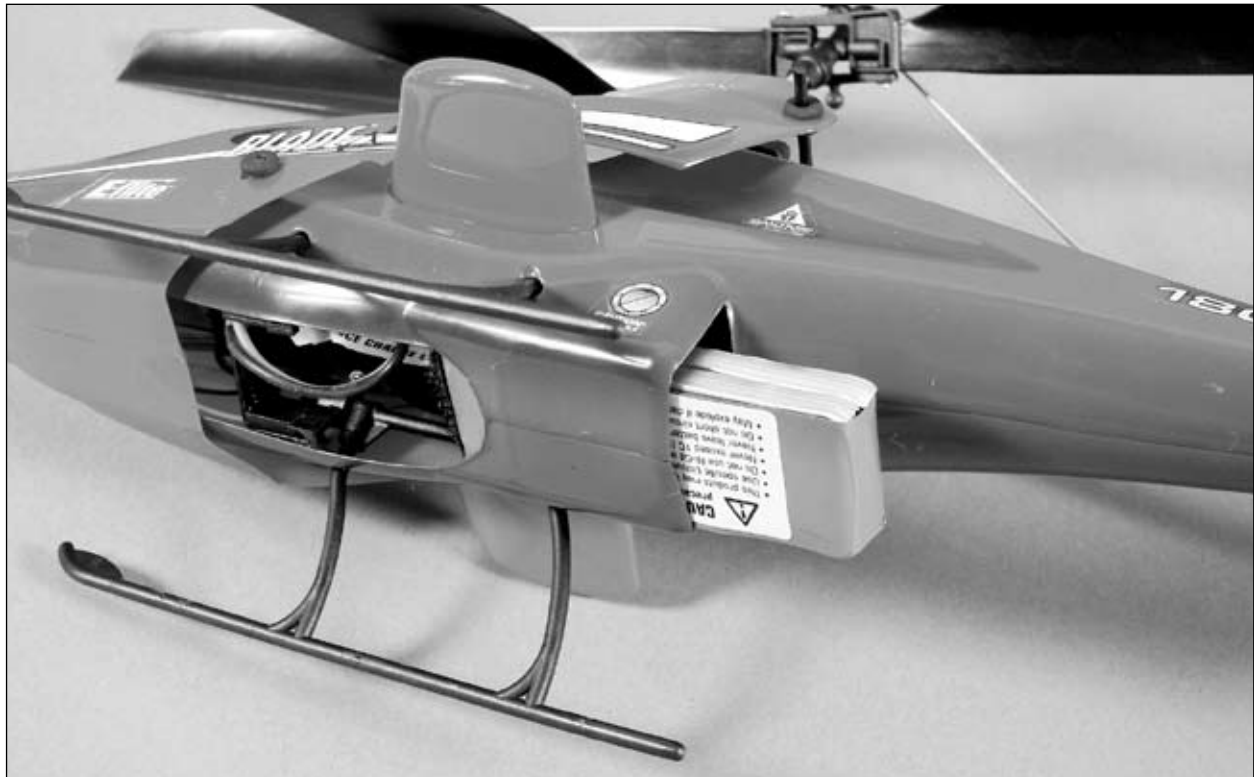

Quick Tip: You can install a tape “pull tab” on the end of the battery to make it easier to remove. You can also carefully remove some additional material from the opening in the rear of the body.



Center of Gravity

Once the battery has been properly installed and secured you will need to check the helicopter's center of gravity. If the helicopter is not properly balanced it can be difficult to control and constantly try to move forward or backward in hover.

To check the center of gravity, lift the helicopter by the stabilizer flybar with the flybar positioned perpendicular to the tail section of the body. Make sure that the helicopter balances level. If it does not, confirm that the battery has been properly installed and reposition it forward or aft if necessary.

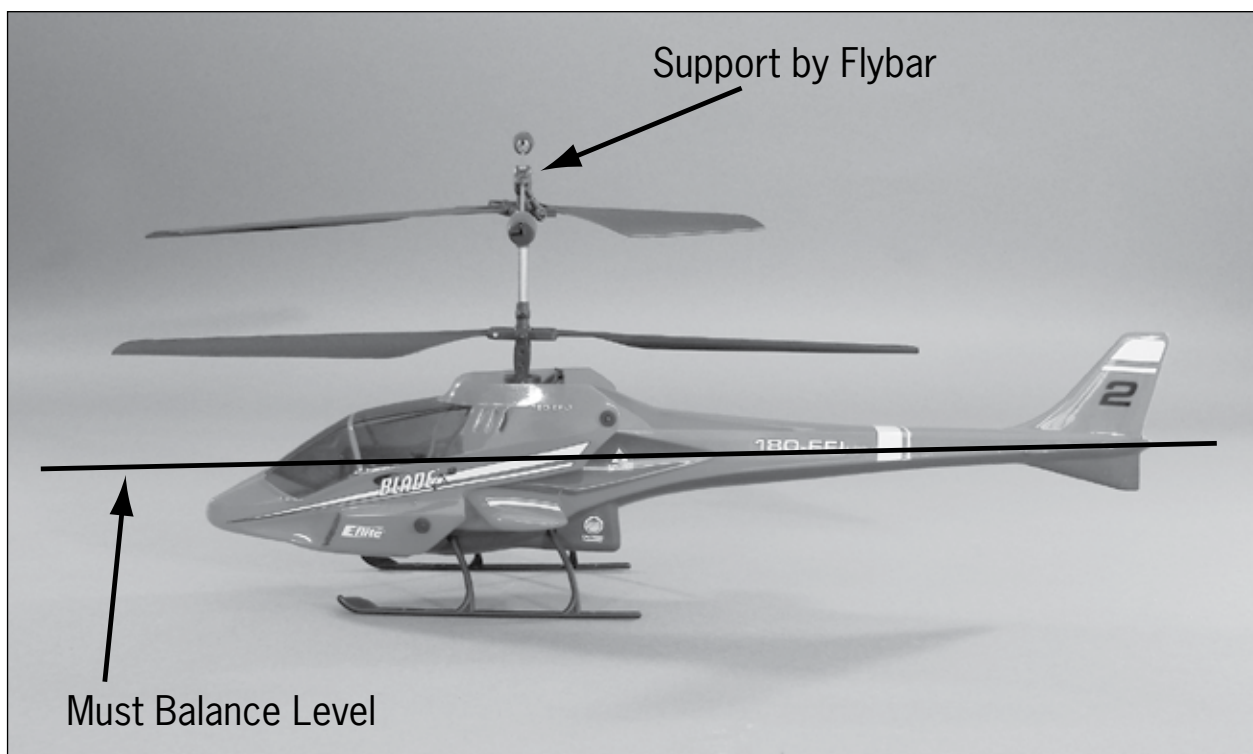

Control Test

Although each Blade™ CX2 model is test flown at the factory, it is a good idea to test the controls prior to the first flight to ensure none of the servos, linkages or other parts were damaged during shipping and handling. **Before proceeding, disconnect both of the main motor plugs from the 4-in-1 control unit, making note of their direction and polarities for proper re-installation after the control test is complete. It is not safe to perform the control test with the main motor plugs connected to the 4-in-1 control unit after power up.**



Turn the transmitter on first then plug the battery into the battery lead of the 4-in-1 unit.



Position the helicopter to view it from the left-hand side. Move the right-hand control stick on the transmitter forward and back to check elevator pitch control. When the stick is pushed forward, the rear servo should push the swashplate upward.

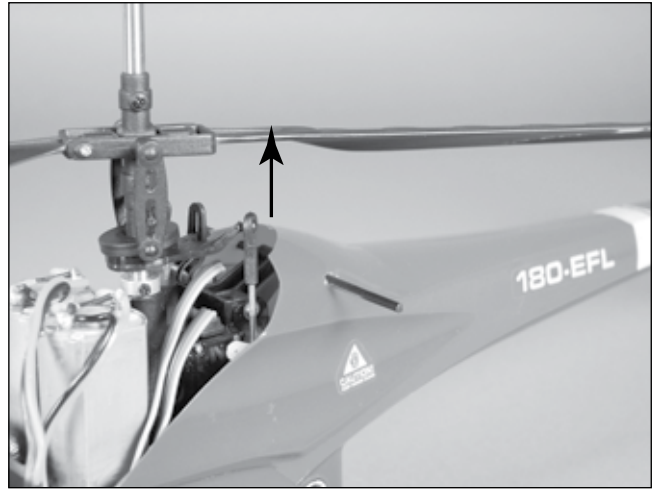

When the stick is pulled back, the rear servo should pull the swashplate downward.

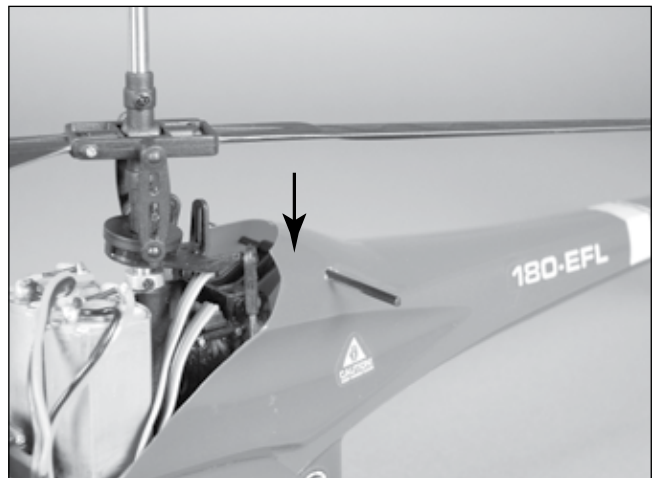

Position the helicopter to view it from the right-hand side. Move the right-hand control stick on the transmitter left and right to check aileron roll control. When the stick is pushed to the left, the forward servo should push the swashplate upward.

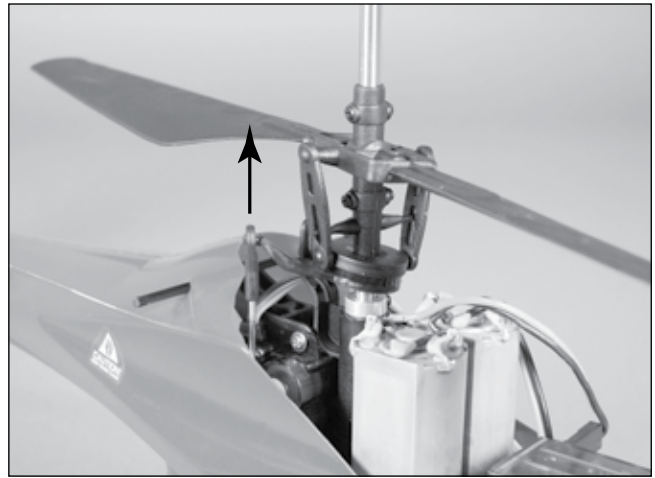

When the stick is pushed to the right, the forward servo should pull the swashplate downward.

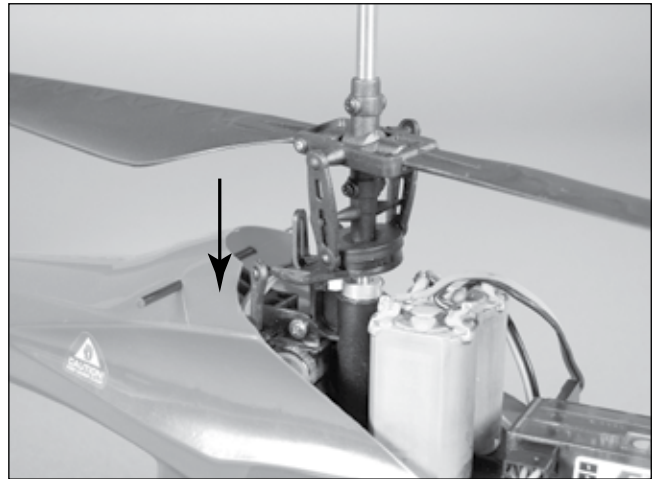

If at any time during the test the controls do not respond properly, double-check the servo reversing switches located under the door on the bottom left front of the transmitter. Dip switches 5 (THR channel reversing), 6 (AIL channel reversing), 7 (ELE channel reversing) and 8 (RUD channel reversing) should be positioned as shown to ensure proper control response.

Note: All other dip switches should also be positioned as shown to ensure proper operation. DO NOT attempt to fly your Blade™ CX2 with any of the dip switches set in positions that are not shown. The remaining dip switches may be used for future expansion.



If the controls still do not respond properly after ensuring that the servo reversing dip switch positions are correct, you may also check the servo connections on the receiver side of the 4-in-1 unit. These should be positioned as follows (when viewing the helicopter from behind):

AIL Channel – Forward aileron servo

ELE Channel – Rear elevator servo

Once you have confirmed that the servo connection locations are correct, all controls should be functioning properly. If you do encounter any problems with your Blade CX2 responding properly to the transmitter, do not fly. Contact Horizon Hobby's Product Support staff at 877-504-0233.

If you have confirmed proper control operation of your Blade CX2, unplug the flight battery from the 4-in-1 unit and reconnect the main motor plugs to the 4-in-1 unit, taking care to keep the proper polarity and location of each as they were before the test. Use the label on the 4-in-1 unit for reference of the proper polarity and locations. Note that the red wire leads are positive (+) and the black wire leads are negative (-).

4-in-1 Control Unit Description, Arming and Motor Control Test

The unique 4-in-1 Control Unit installed on your Blade™ CX2 is a lightweight combination of 6-channel 2.4GHz DSM® receiver, main motor mixer, main motor electronic speed controls, and piezo gyro. The 4-in-1 unit also contains a gyro gain trimmer pot, main motor proportional mix trimmer pot and status LED.

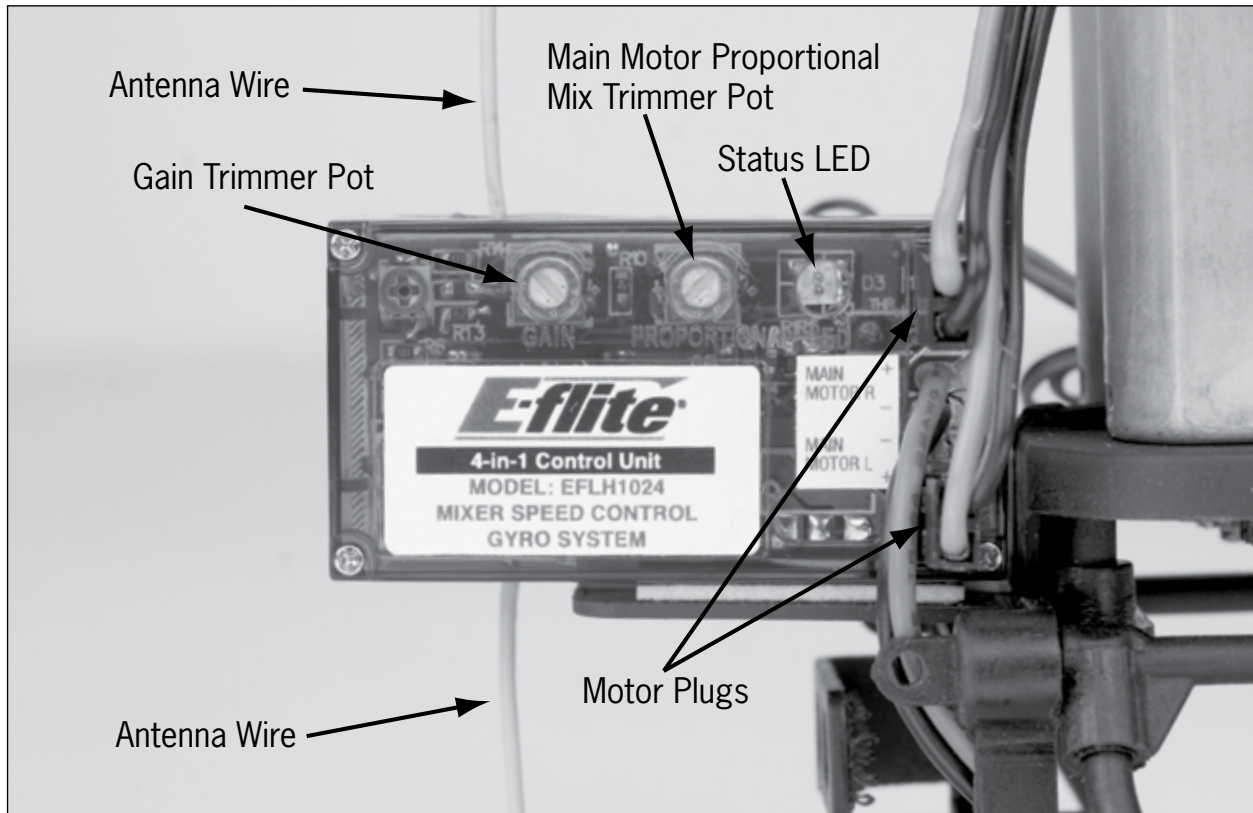

If you should ever need to access the 4-in-1 unit (usually only required if making adjustments to the gyro gain or main motor proportional mix trimmer pots, as outlined on pages 32–34), you can do so by removing the front body/canopy from the helicopter. This is accomplished by sliding the body/canopy and rubber grommets off the body mount rods.

Note: It will not be necessary to access the 4-in-1 unit for proper arming and usual operation.

The following checklist contains the steps you must follow to ensure proper arming and operation of the 4-in-1 unit as well as proper motor control response:

- ❑ **Each time before you fly you must ALWAYS turn on the transmitter power first before connecting the flight battery to the 4-in-1 unit. Never connect the flight battery to the 4-in-1 unit before first powering on the transmitter.**

Also, never turn off the transmitter before disconnecting the flight battery from the 4-in-1 unit first.

- ❑ **Both the throttle (left-hand) stick and throttle trim MUST be in their lowest possible position in order for the 4-in-1 unit to arm the electronic speed controls for the main motors.**

If this is the first test flight, or a test flight following repairs, you will also want to center the rudder, aileron and elevator trims.

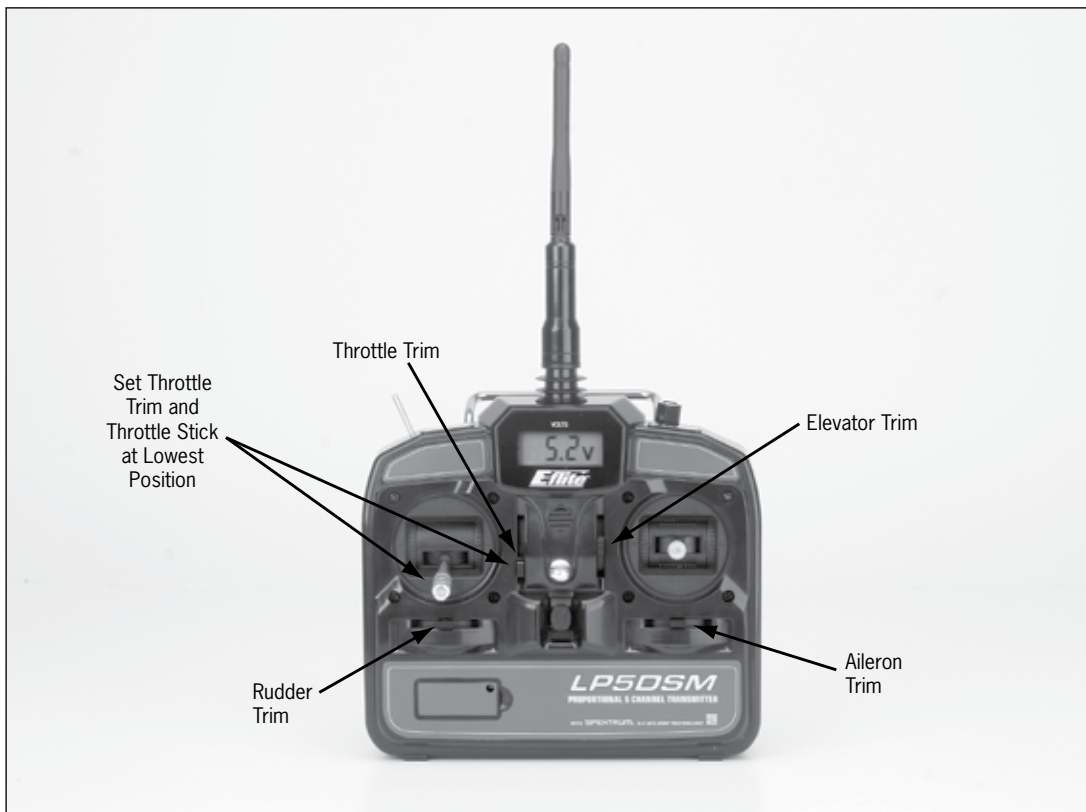

- ❑ After confirming that the transmitter has been turned on and has an adequate level of battery power as displayed by the LCD screen at the top of the transmitter, it is now safe to connect the flight battery to the 4-in-1 unit.

Note: Each time you power the transmitter on, it will enter “Bind Mode” (See pages 39–40 for more information regarding “Bind Mode”) for a few seconds, as indicated by the red blinking LED located under the door on the left bottom front of the transmitter. Once this LED becomes solid, the transmitter is no longer in bind mode. We recommend waiting to connect the flight battery to the 4-in-1 unit until after the transmitter has exited bind mode, otherwise the 4-in-1 unit may not arm properly or as quickly.

- ❑ **With battery power applied, the 4-in-1 unit status LED will blink red, and then blink green. It is extremely important that you do not move or sway the helicopter once the status LED begins to blink green confirming that the initialization process and calibration of the gyro has begun.** It is OK to move the model when the status LED is blinking red (as in the time it takes to connect the flight battery to the 4-in-1 unit and place the model at rest), as long as the model remains motionless when the status LED begins to blink green.
- ❑ **When the status LED becomes solid green, the unit is armed and ready for flight.** Use caution as both main motors will now run with throttle stick or throttle trim input. Do not advance the throttle stick or trim until you are clear of the rotor blades and ready to fly.

Note: If the status LED does not become solid green, please review the following:

- If after blinking red the status LED becomes solid red, you have a positive Radio Frequency (RF) link between the transmitter and receiver of the 4-in-1 unit, but the throttle stick and throttle trim may not be in their lowest possible positions. Check to be sure that both the throttle stick and throttle trim are in their lowest possible position and the status LED should blink green then become solid green indicating the unit is armed and ready for flight. Proceed to the next step of the checklist once the unit is armed.
- If after blinking red the status LED continues to flash from green to red, you do not have a positive RF link between the transmitter and receiver of the 4-in-1 unit. First, check to be sure that the transmitter has been powered on and has an adequate level of battery power. If the transmitter was indeed powered on, power both the transmitter and 4-in-1 unit down, then follow the steps to bind the 4-in-1 unit's receiver to the transmitter (see pages ** to ** for more information). Once you have confirmed that the transmitter and receiver are properly bound, the 4-in-1 unit should now arm normally.

If your 4-in-1 unit will not arm after following the guidelines as listed above, contact Horizon Hobby's Product Support staff at 877-504-0233.

- ❑ **Once you have placed the helicopter in a safe area to test motor control, free from obstructions, and are clear of the rotor blades, you can safely begin to power up the model.**
- ❑ Advance the throttle (left-hand) stick slowly, just until the main rotor blades begin to spin. Be sure not to advance the throttle stick too far to keep the helicopter from lifting off the ground. Note the direction that each of the main rotor blades spins. When viewed from the top, the lower main rotor blade should spin clockwise and the upper main rotor blade should spin counterclockwise. If either rotor blade is operating in the wrong direction, unplug the battery, then simply reverse its motor plug polarity on the 4-in-1 unit. Note that the proper polarity is marked on the label of the 4-in-1 unit.
- ❑ After confirming that the direction of rotation for both rotor blades is correct, it is best to confirm that both rotor blades respond properly to rudder control inputs. With both main rotor blades spinning at a low level of power, move the rudder (left-hand) stick all the way to the right. This should cause the speed of the upper main rotor blade to increase, and the speed of the lower main rotor blade to decrease. Next, move the rudder stick all the way to the left. This should cause the speed of the lower main rotor blade to increase and the speed of the upper main rotor blade to decrease. If both rotor blades are not responding properly to rudder input, simply reverse the locations of their motor plugs on the 4-in-1 unit. Note that the proper motor plug locations are marked on the label of the 4-in-1 unit.
- ❑ After confirming both main rotor blades respond properly to rudder inputs, your Blade™ CX2 is now ready for flight. However, please be sure to review the following sections of the manual before proceeding with the first flight.

Installing the Optional Training Gear

If the Blade™ CX2 is your first helicopter model, we suggest that you install the optional Training Gear Set (EFLH1205) before making your first flight. The training gear helps to further increase the stability of the model while also providing added support and cushioning to prevent tip-overs and damage to the model from abrupt landings.

Installing the training gear takes only a few minutes following these steps:

- The Training Gear Set includes four training gear rods with plastic balls installed, four training gear rod to landing skid attachments, four screws and one training gear rod mounting base.

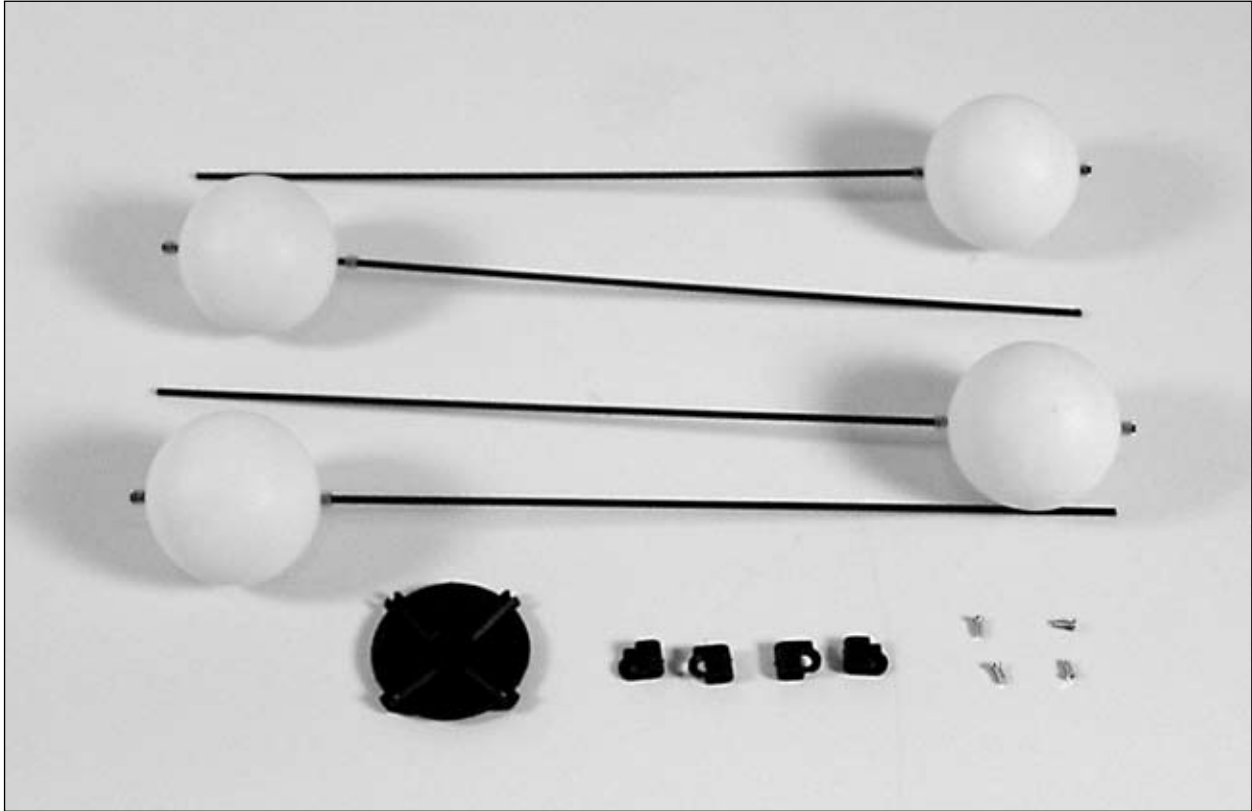

- Locate the four training gear rod to landing skid attachments and four screws. Note that there are two each of two types of attachments. Carefully snap two of the attachments onto the landing skids forward of the landing skid struts. The side of the attachment with the large hole should face outward, away from the helicopter, and forward to the front of the helicopter.
- Next, carefully snap the remaining two attachments onto the landing skids behind the landing skid struts. The side of the attachment with the large hole should face outward, away from the helicopter, and backward to the rear of the helicopter.

- Once you have installed all four attachments, install the four screws making sure that they thread properly into the back side of the attachment. It may be helpful to squeeze the attachment with a pair of pliers to make it easier to thread the screw into the backside of the attachment. Do not tighten the screws all the way at this time, as the attachments will need to be adjusted for proper alignment once the training gear rods are installed.

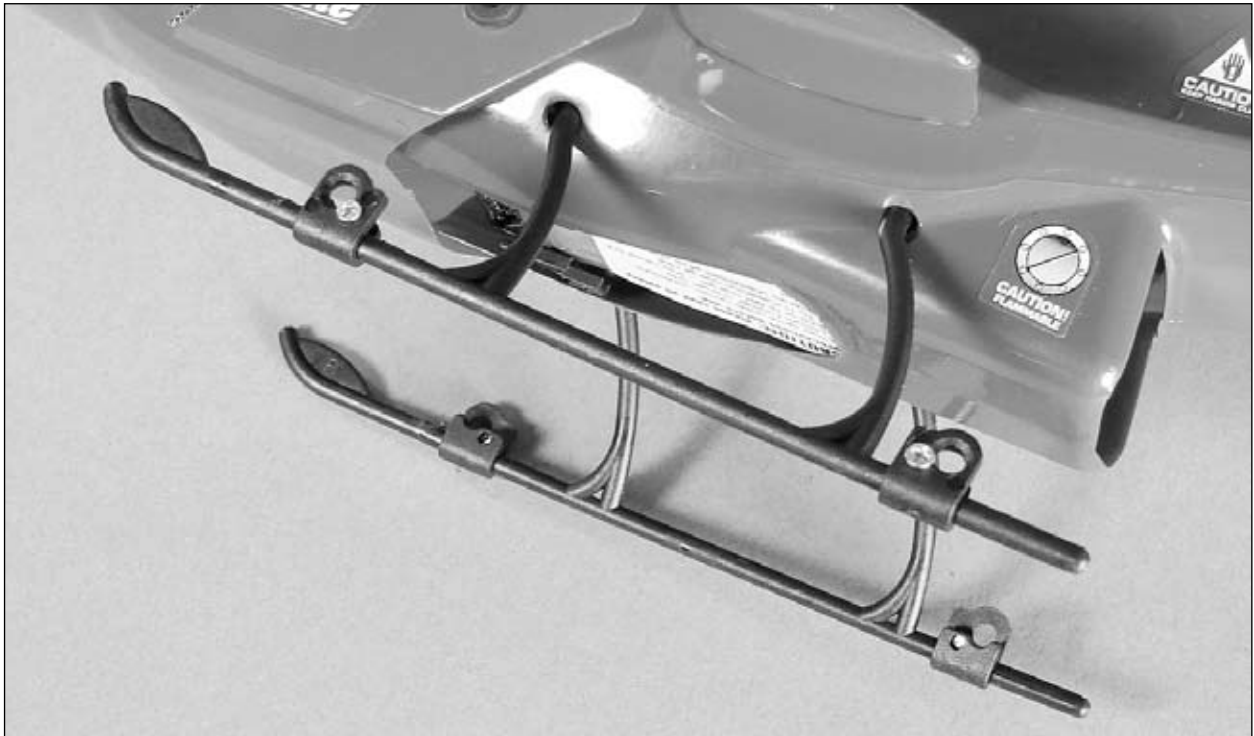

- Locate the four training gear rods and rod mounting base. Note that the rod mounting base has four channels into which the training gear rods will mount. The open side of these channels will face upward toward the bottom of the helicopter when properly installed.
- Carefully pass each of the rods through the attachments on the landing skids and into the channels on the base. Take care to not pull the landing skids out of their mounts in the battery supports.

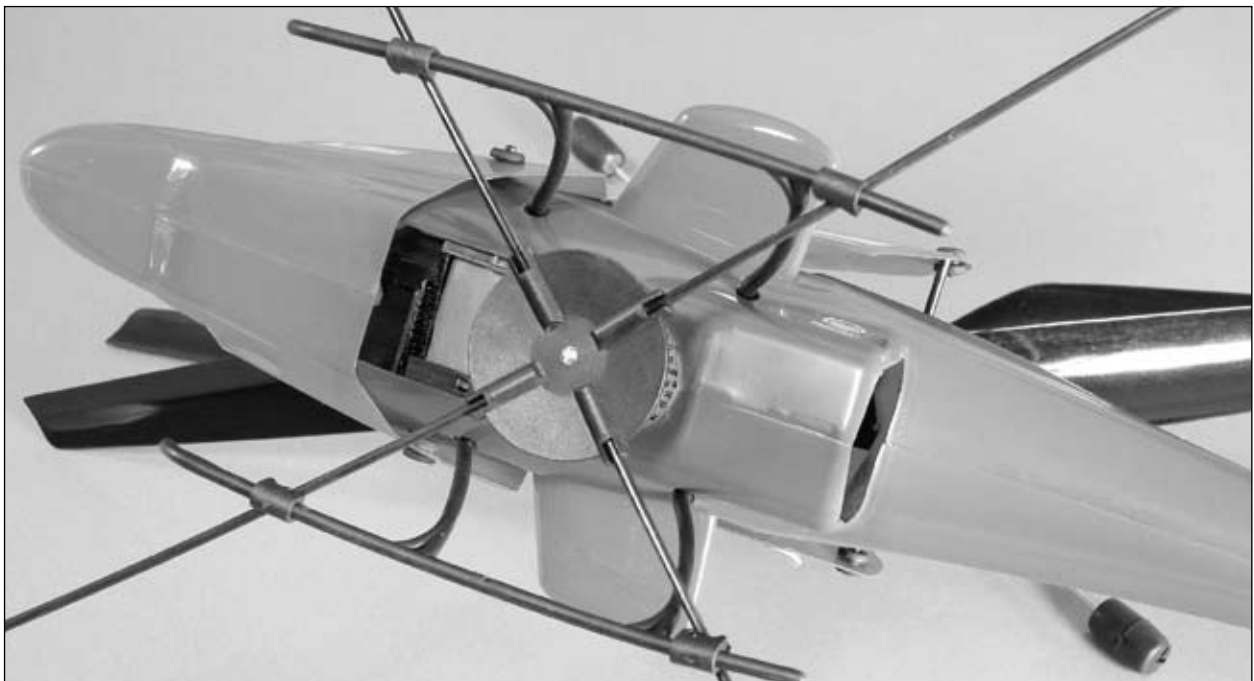

- After ensuring that the rods are secure in the base, adjust the positions of the attachments on the landing skids so that the base is centered under the main shaft of the helicopter. Once confirming the base is centered under the main shaft, make sure that each of the landing skids is still firmly installed in the mounts of the battery supports. Note that the landing skids may be pulled slightly inward under pressure of the training gear rods.
- With the attachments, rods and base properly positioned, you can now tighten the attachment screws until they are just snug. Take care when tightening the screws to prevent stripping the backside of the attachments.
- Adjust the position of the tubing keepers and plastic balls on the training gear rods so that the balls are positioned approximately 1/8" from the end of each rod. Be sure that the tubing keepers are positioned so that the plastic ball can still spin freely on the rod.

Your Blade™ CX2 is now ready for flight with the training gear installed.



Understanding the Controls

If you are not familiar with the controls of your Blade™ CX2, please take a few minutes to familiarize yourself with them before attempting your first flight.

The left-hand stick on the transmitter controls both throttle (climb/descend) and rudder (yaw left/right). When the left-hand stick and throttle trim lever are in their lowest positions, the main rotor blades will not spin. Advancing the stick upward will increase the speed of the main rotor blades. Increasing the speed of the main rotor blades will cause the model to climb.

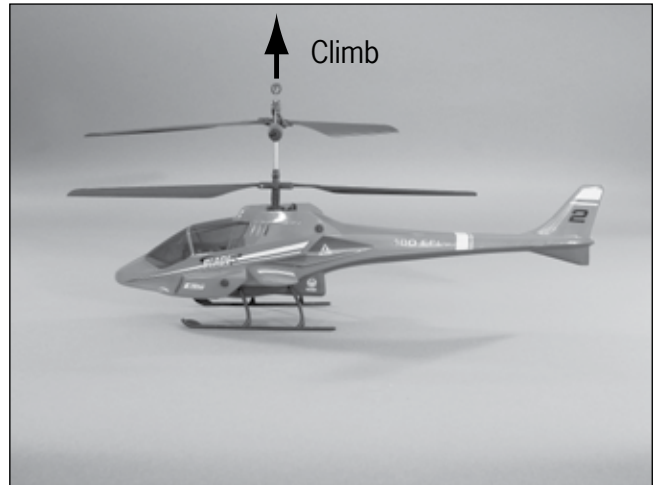

Decreasing the speed of the main rotor blades by lowering the left-hand stick will cause the model to descend.

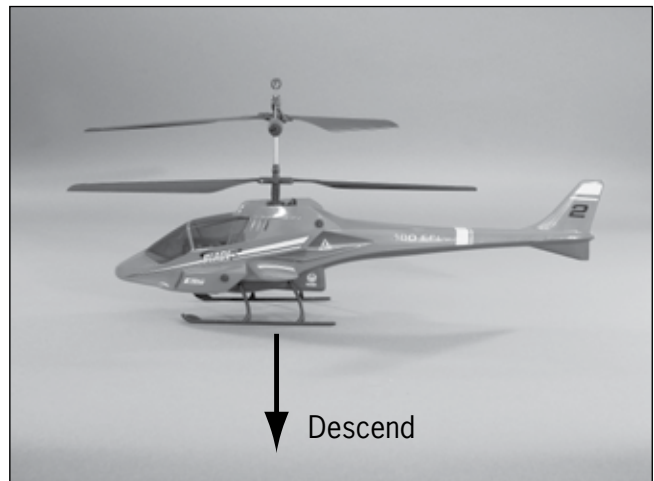

After lifting the model off the ground, you can balance the throttle by carefully moving the left-hand stick up and down so that the model will hold a stationary hover without climbing or descending.

You can also use the throttle trim to adjust the throttle value for a given stick position. For example, raising the throttle trim will allow the model to hover at a lower throttle stick position. However, if you do raise the throttle trim, you MUST remember to lower it (and the throttle stick) to the lowest possible position IMMEDIATELY in the event of a crash or rotor blade strike.

Failure to lower the throttle trim (and throttle stick) to its lowest possible position immediately in the event of a crash could result in damage to the main motor ESCs in the 4-in-1 unit, which may require replacement of the 4-in-1 unit.

Moving the left-hand stick to the left will turn (yaw) the nose of the helicopter to the left about the axis of the main shaft. This is accomplished by increasing the speed of the lower main rotor blade while decreasing the speed of the upper main rotor blade.

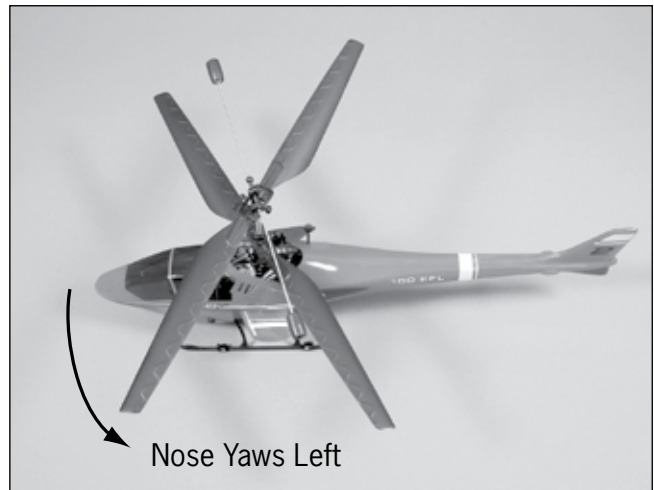

Moving the stick to the right will turn (yaw) the nose of the helicopter to the right about the axis of the main shaft. This is accomplished by increasing the speed of the upper main rotor blade while decreasing the speed of the lower main rotor blade.

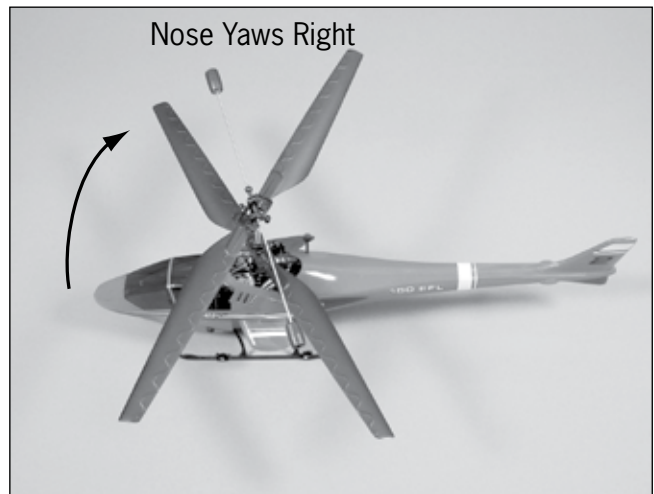

The rudder trim can be used to help keep the nose of the helicopter from rotating to the left or right when in hover with no rudder stick input. For example, if the nose of the helicopter drifts to the right when in hover, add left rudder trim until the nose stays as close to straight as possible. Also note that further adjustments to the rudder trim can be made using the Main Motor Proportional Mix Trimmer Pot as outlined on page 32–33.

The right-hand stick controls both elevator (pitch fore/aft) and aileron (roll). Pushing the stick forward will pitch the nose of the helicopter downward, allowing the helicopter to be flown forward.

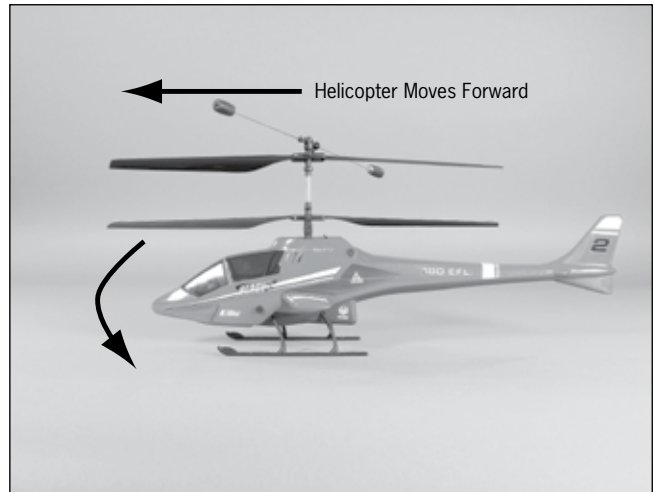

Pulling the stick backward will pitch the nose of the helicopter upward, allowing the helicopter to be flown backward.

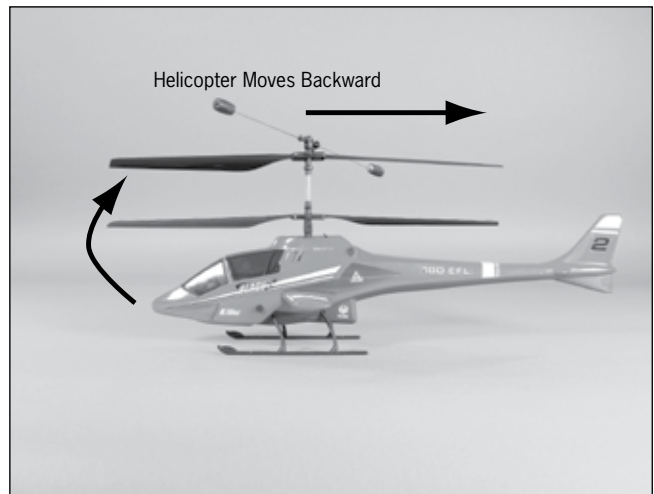

The elevator trim can be used to help keep the helicopter from drifting forward or backward when in hover with no elevator stick input. For example, if the helicopter drifts forward when in hover, pull the elevator trim downward until the helicopter hovers as level as possible with no forward drifting.

Moving the stick to the left will roll the helicopter to the left, allowing the helicopter to be flown to the left.

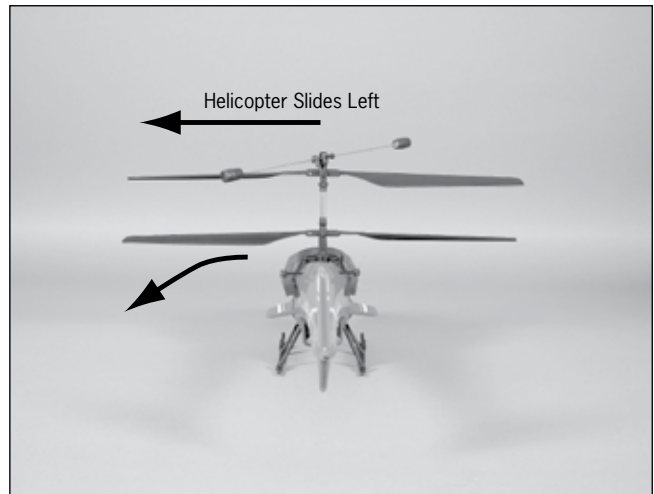

Moving the stick to the right will roll the helicopter to the right, allowing the helicopter to be flown to the right.



The aileron trim can be used to help keep the helicopter from drifting left or right when in hover with no aileron stick input. For example, if the helicopter drifts to the right when in hover, add left aileron trim until the helicopter hovers as level as possible with no drifting to the right.

Once you have become familiar with the controls of the helicopter, you are almost ready to fly.

Choosing a Flying Area

When you are ready for your first flight, you will want to select a large, open area that is free of people and obstructions. **We strongly recommend an indoor area with at least 20-feet by 20-feet of floor space and no less than 8-foot ceilings.**

If you have to make your first flight (and subsequent flights) outdoors, you MUST pick a time when wind conditions are COMPLETELY CALM. Due to the relatively small size and low weight of the Blade™ CX2, even the slightest amount of wind can cause you to lose control, or the rotor blades to strike each other, resulting in a crash.

Flying the Blade CX2

Having followed the proper 4-in-1 control unit arming procedure, confirmed proper control of the servos and motors, and found a suitable flying area, your Blade CX2 is ready for flight.

In addition to reviewing the flight maneuvers outlined below, we recommend that you watch the included Instructional Video CD to see many of these maneuvers and adjustments performed by the Blade CX2 and pilot.

- Slowly raise the throttle stick, increasing the speed of the main rotor blades until the model begins to lift off. **Do not raise the throttle stick too quickly as the model could climb too fast causing you to lose control or make contact with objects above.**
- Lift the model off the ground just a few inches and concentrate on balancing the left-hand (throttle) stick position so that the model holds a steady hover altitude. In some cases it may be best to make a few short “hops” to an altitude of just a few inches until you become familiar with the control inputs and trim settings required to maintain a steady hover and altitude.

As you will find, the Blade CX2 requires minor throttle adjustments to maintain its altitude in hover. Remember to keep these throttle adjustments as minimal as possible as large adjustments could result in a loss of control and/or a possible crash.

- While attempting to establish a low-level hover, you can also check to see if any trim adjustments are required to help keep the Blade CX2 from constantly drifting in various directions. If you find the helicopter constantly drifts without any directional control input, it will be best to land the model before making any adjustments to the trim levers. Additional details regarding the location and function of the trim levers can be found on pages 26–29.

If the nose of the helicopter is drifting to the left or right, you will need to adjust the rudder trim. You can also adjust the Main Motor Proportional Mix if you experience any difficulties in trimming nose drift with the rudder trim lever only. Please see pages 32–33 for more information regarding Main Motor Proportional Mix Trimmer Pot adjustment.

If the helicopter is drifting forward or backward, you will need to adjust the elevator trim.

If the helicopter is drifting to the left or right, you will need to adjust the aileron trim.

Continue to make trim adjustments until the helicopter can hover at a low altitude with very little drifting and directional control input. If the Blade CX2 is your first helicopter model, it may be best to have the help of an experienced helicopter pilot to trim the model for you before making your first flight.

- Once you have the Blade CX2 properly trimmed and maintaining a stable low-level hover, practice using the rudder, elevator and aileron controls to get a feel for how the helicopter responds to control inputs. Remember to keep the control inputs as minimal as possible to prevent over-controlling the helicopter, especially when in hover.

- After becoming comfortable with hovering the Blade™ CX2 at low-levels of altitude just a few inches off the ground, you can transition to hovering and flying the helicopter at higher altitudes of approximately three to four feet. At these higher altitudes you will be able to get a feel for the flight characteristics of the Blade CX2 when it is flying out of “ground effect.”
- If at any time during flight you feel like the helicopter is drifting out of control, simply release all of the controls except for throttle. You will need to use the throttle to maintain altitude, but due to the inherent stability of the coaxial counter-rotating blades, the Blade CX2 will simply return to a stable hover on its own if space allows.
- Don't be afraid to set the helicopter down on the ground quickly by lowering the throttle when approaching walls or other obstacles to help prevent main rotor blade strikes. Also, the optional Training Gear Set (EFLH1205) will help to further prevent damage to the helicopter in the event that you must make an abrupt landing to avoid walls or other obstacles.
- **IN THE UNFORTUNATE EVENT OF A CRASH OR ROTOR BLADE STRIKE, NO MATTER HOW MINOR OR MAJOR, YOU MUST LOWER BOTH THE THROTTLE (LEFT-HAND) STICK AND THROTTLE TRIM TO THEIR LOWEST POSSIBLE POSITION AS QUICKLY AS POSSIBLE TO PREVENT DAMAGE TO THE ESCS OF THE 4-IN-1 UNIT.**

Failure to lower both the throttle stick and throttle trim to their lowest possible positions in the event of a crash could result in damage to the main motor ESCs in the 4-in-1 unit, which may require replacement of the 4-in-1 unit.

Note: Crash damage is not covered under warranty.

- **It is extremely important when hovering and flying the Blade CX2 to be aware of the power level of the Li-Po battery pack. If at any time the helicopter begins to require more throttle than typical to maintain hover or flight, or has lost the ability to maintain hover or flight due to significant loss of power, you must land the helicopter and power the motors down IMMEDIATELY to prevent over-discharge of the Li-Po battery pack.**

If you continue to run the motors after noticing a loss in power it is possible to discharge the Li-Po battery pack too far, causing permanent damage to the pack. Over-discharge of the Li-Po battery pack can result in shortened flight times, loss of power output or failure of the pack entirely.

- Once you have gained experience and confidence in hovering the Blade CX2, you can attempt more advanced maneuvers including:

Forward Flight

Backward Flight

Pirouettes

Skidding Takeoffs

Skidding Landings

Spot Landings

Main Motor Proportional Mix Trimmer Pot Description and Adjustment

The Main Motor Proportional Mix Trimmer Pot can be found on the left side of the 4-in-1 control unit. This “proportional” trimmer pot adjusts the amount of mixing between the main motors allowing you to “fine-tune” the rudder trim (sub-trim) to help prevent the nose from drifting to the left or right when in hover.

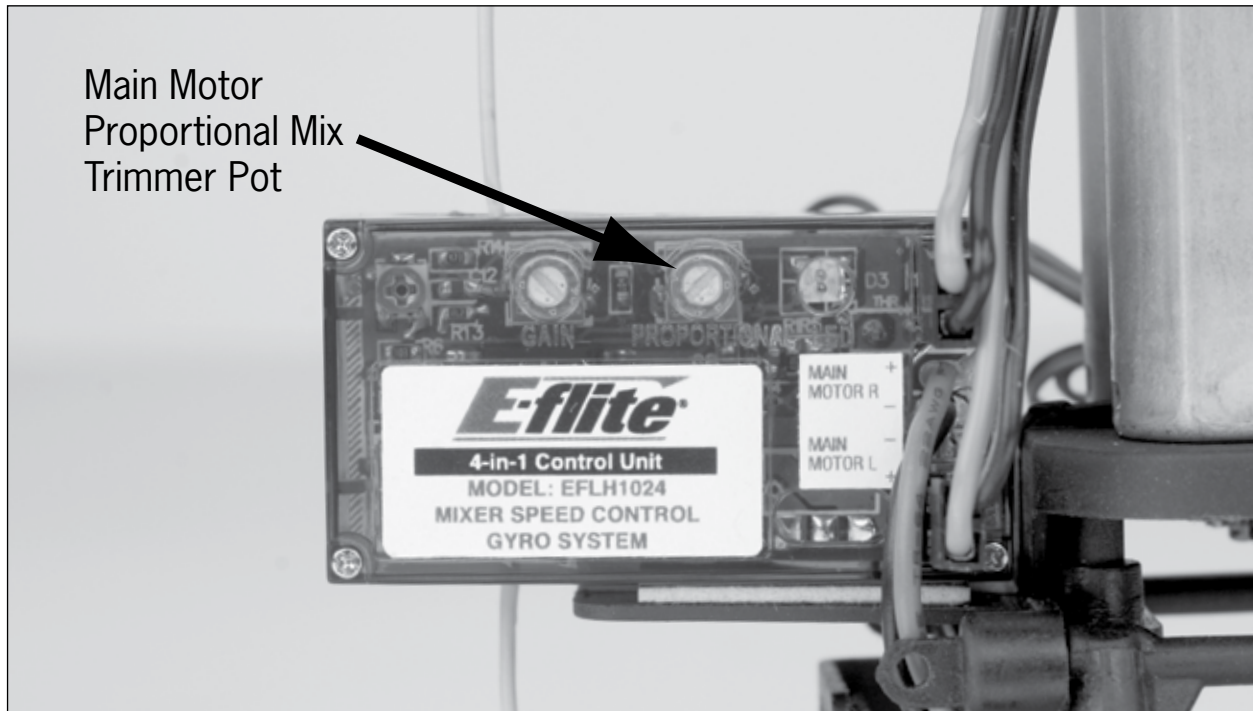

- In a stable hover, with the rudder trim centered and no rudder control input, note toward which direction the nose of the helicopter is trying to drift. If the nose of the helicopter is drifting to the left, you will want to increase power to the right-hand motor (spinning the upper main rotor blade). This is accomplished by turning the “proportional” trimmer pot clockwise. (+)



- If the nose of the helicopter is drifting to the right in hover, you will want to increase the power to the left-hand motor (spinning the lower main rotor blade). This is accomplished by turning the “proportional” trimmer pot counterclockwise. (–)



Note: You must always power down the 4-in-1 unit before making adjustments to the proportional mix trimmer pot. Any changes made to the trimmer pot will not take effect until the 4-in-1 unit is re-initialized and re-armed.

Also, you should always center the rudder trim lever on the transmitter after making adjustments to the proportional mix trimmer pot on the 4-in-1 unit.

Note: Be sure to use the proper size and type of screwdriver to carefully make adjustments to the trimmer pot. Use of the improper size and type of screwdriver or too much force can damage the trimmer pot. Also be sure to take your time when making adjustments to the proportional trimmer pot as it may only require very slight adjustment to achieve the desired level of performance.

As the battery output voltage decreases throughout the flight, it may be necessary to make small adjustments to the rudder trim or rudder control input in order to keep the nose of the helicopter straight. These small adjustments can be made using the rudder trim lever or rudder control stick and do not require additional adjustments of the proportional trimmer pot.

Gyro Gain Trimmer Pot Description and Adjustment

The “gain” trimmer pot adjusts the gain setting value of the piezo gyro used to aid in keeping the tail of the helicopter straight/on heading during flight.



- The gain value is set too high if the tail of the helicopter twitches/bounces quickly from side to side when in hover. If this is case for your model, reduce the gyro gain in small increments until the tail of the helicopter no longer twitches/bounces from side to side in hover.

Turn the gyro gain trimmer pot counterclockwise (-) to decrease gyro gain.

- The gain value is set too low when the tail of the helicopter feels “loose” during flight, requiring constant left and right rudder inputs to maintain heading when in hover. If this is the case for your model, increase the gyro gain in small increments until few, if any, left and right rudder inputs are required to maintain heading.

Turn the gyro gain trimmer pot clockwise (+) to increase gyro gain.

Note: When adjusting the gyro gain trimmer pot, the changes will take effect without the need to power down and re-arm the 4-in-1 unit. However, please exercise extreme caution when adjusting the gyro gain trimmer pot with the model armed to prevent personal injury or damage to the model.

Upper Main Rotor Blade Tracking Adjustment

Caution: Be sure to maintain a safe distance from the helicopter (approximately 10–15 feet) when tracking the Upper Main Rotor Blade.

Your Blade™ CX2 is equipped with an adjustable linkage between the Stabilizer Flybar and Upper Main Rotor Blade. This linkage allows you to adjust the tracking of the upper main rotor blade for smoother and more stable flight performance.



- You can check the upper main rotor blade tracking either on the ground or in the air at eye level. It might be a good idea to have an assistant on hand to help sight the blade tracking.
- Once the main rotor blades have been brought up to speed, note whether the tips of the upper main rotor blade are tracking in the same plane or not.

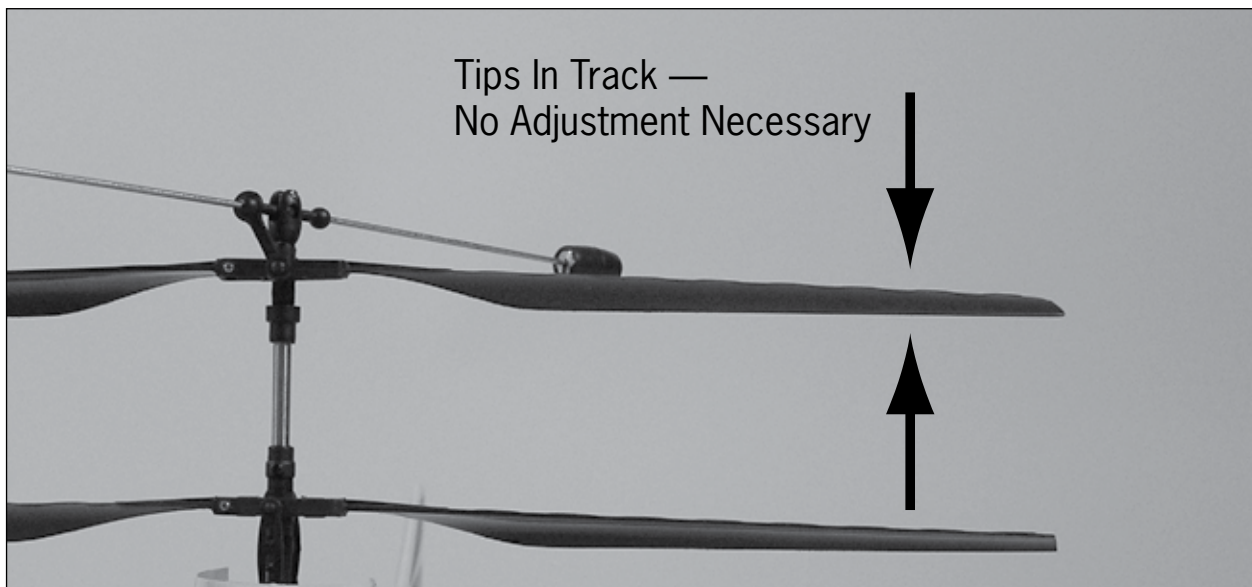
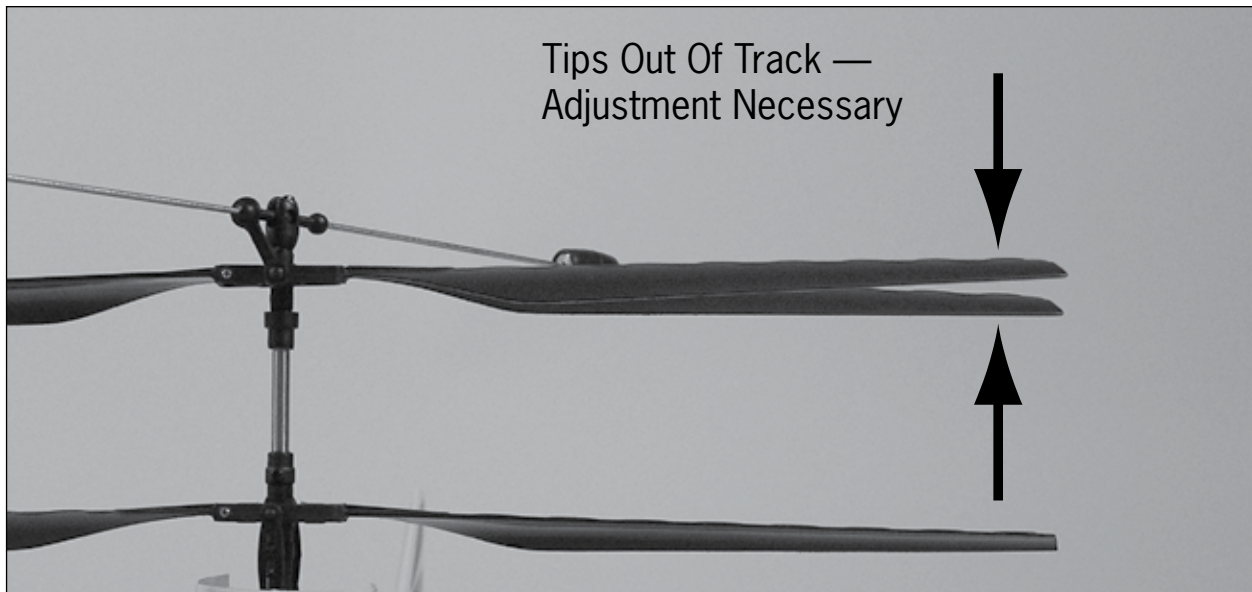

- If the tips are not tracking in the same plane, power the helicopter down to make adjustments to the adjustable linkage. You can start by turning the ends of the linkage in one-half to one-full turn at a time. Power the helicopter up again and re-check the blade tracking.

If the tracking has gotten better, continue to turn the ends of the linkage in one-half to one-full turn at a time until the tips are tracking in the same plane.

If the tracking has gotten worse after first turning the ends of the adjustable linkage in, turn the ends of the linkage back out one-half to one-full turn at a time. If the tracking then gets better, continue to turn the ends of the linkage out one-half to one-full turn at a time until the tips are tracking in the same plane.

Typically, not much adjustment should be necessary to properly track the tips of the upper main rotor blade. However, due to the small size of the linkage ends and threaded rods it may not always be possible to achieve absolutely perfect blade tracking. Don't worry as the helicopter will still perform well as long as the blade tracking is adjusted as closely as possible.

Note: It will not be necessary to adjust the Lower Main Rotor Blade tracking as fixed links are used between the rotor blade and swashplate.

Channel 5 Knob Description and Function

The transmitter included with your Blade™ CX2 is equipped with an optional-use “Channel 5” knob (labeled as “CH 5”) on the top right panel.

This knob allows you to control function of the transmitter’s 5th channel. This channel remains unused for flying the Blade CX2, however, it is available for use in controlling a variety of potential optional features including actuation of an additional servo or certain electronic components. It allows full proportional control of the 5th channel from approximately 0–100% travel.

The knob can be operated in either direction for control. You can use either the most clockwise (+) or most counterclockwise (-) position for 0 or 100% travel, and you will achieve approximately 50% travel with the knob in the middle position, pointing directly to the rear of the transmitter.

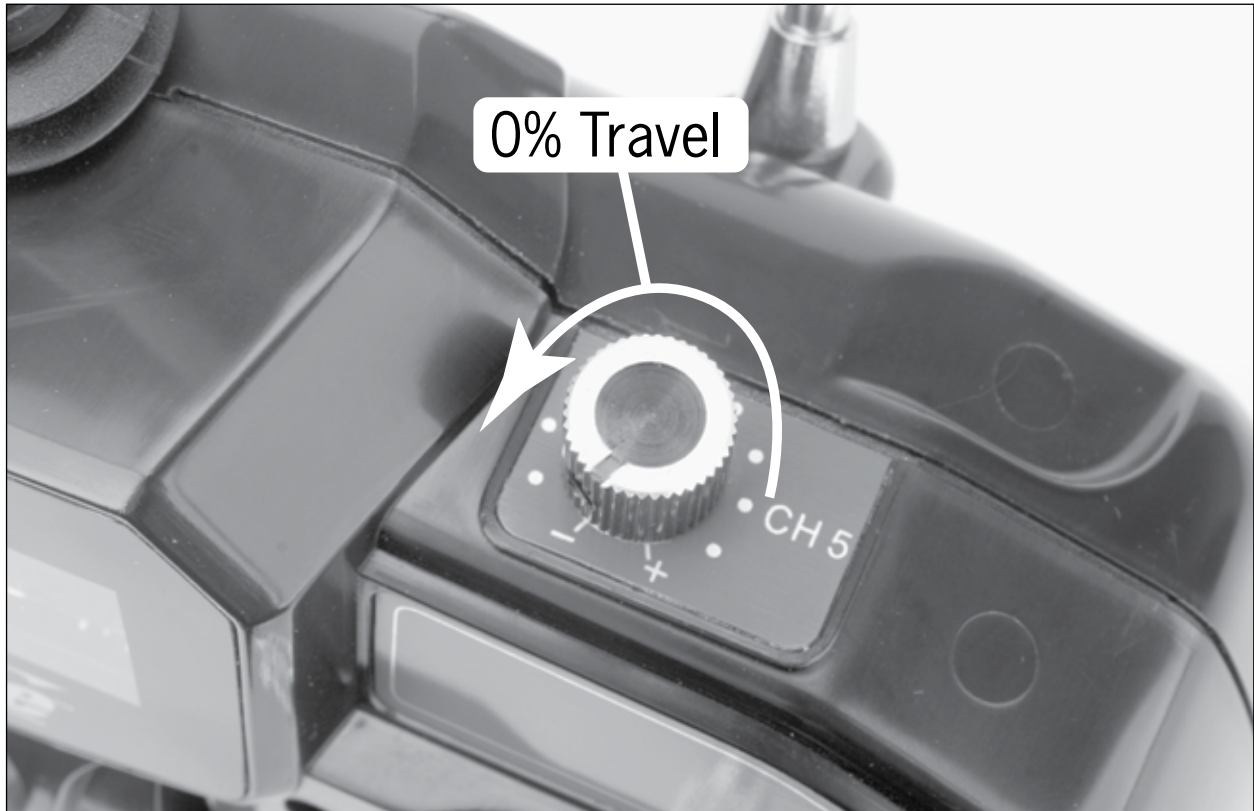

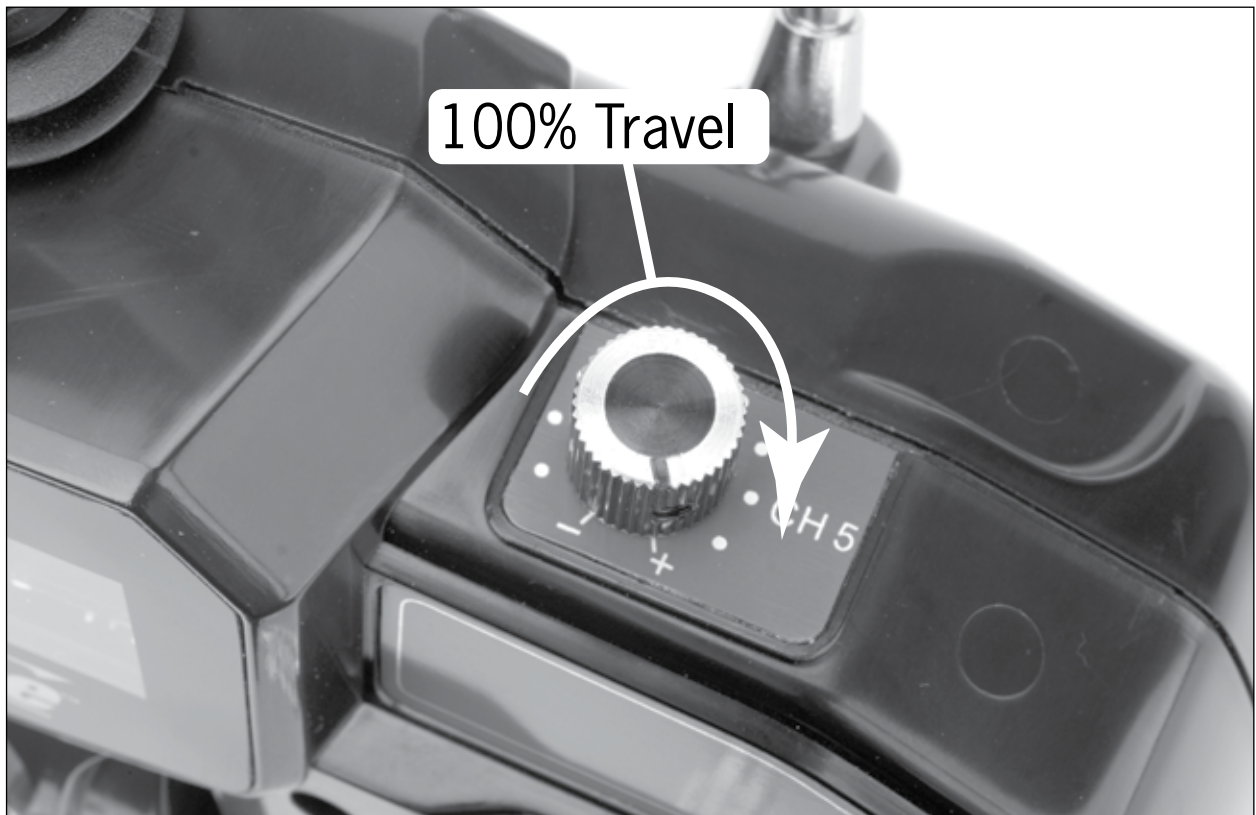
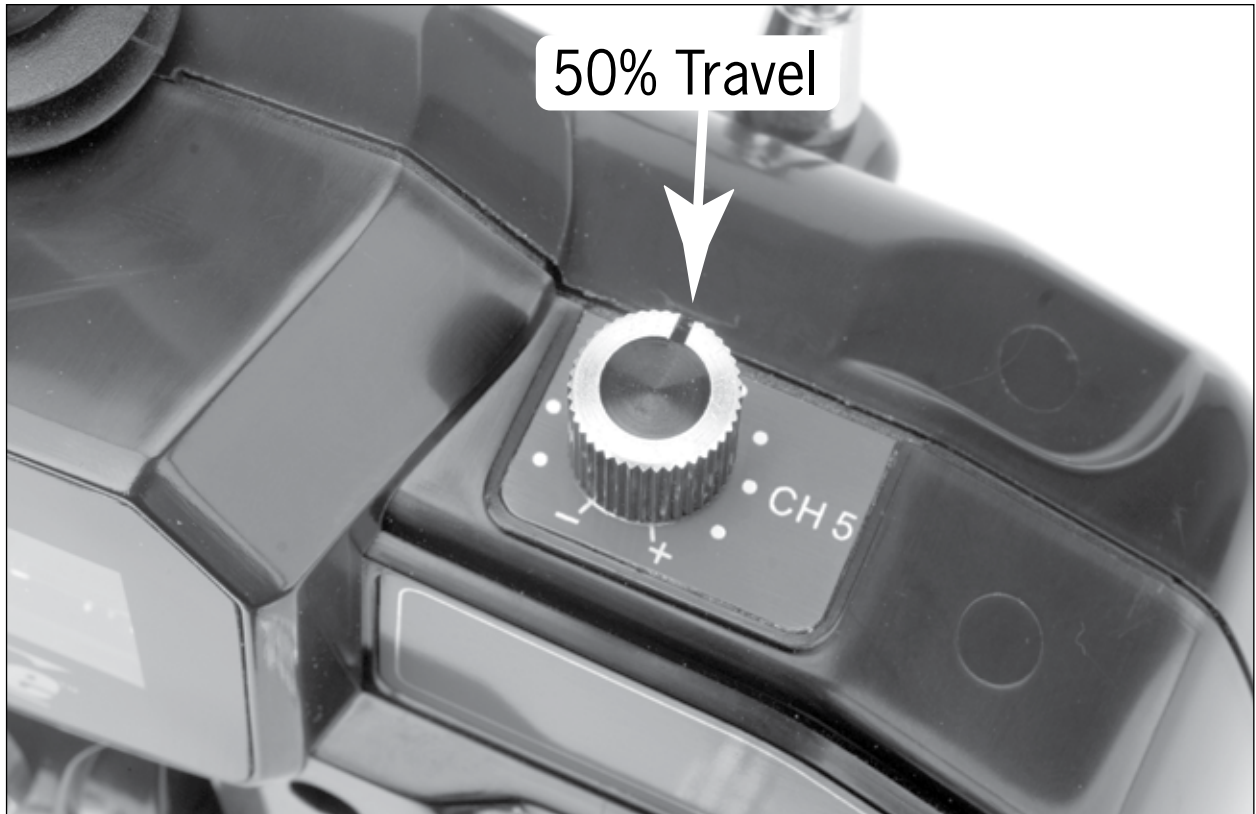

Transmitter and 4-in-1 Control Unit Receiver Binding and Fail-Safe

Binding is the process of programming the receiver to recognize the GUID (Globally Unique Identifier) code of a single specific transmitter. If you ever find that it is necessary to replace your transmitter or the 4-in-1 control unit in your model, it will be necessary for you to “Bind” the new transmitter or 4-in-1 control unit receiver to your existing transmitter or receiver for proper operation.

During the binding process, the smart fail-safe (SmartSafe™) positions of your system are also set. With SmartSafe, in case of loss of signal, the throttle will go to the preset position that was stored during the binding process and all other channels will hold their last position. And if the receiver (4-in-1 Control Unit) is powered on before the transmitter, all channels but throttle will go to the fail-safe positions that were stored during the binding process, while the throttle channel will not generate a pulse in order to prevent the ESC(s) from arming.

Note: Because the SmartSafe positions are set during the binding process, it is important to set all channels to the preferred fail-safe positions before proceeding. In the case of the Blade™ CX2, we strongly recommend setting the throttle stick and throttle trim to their lowest positions, and the rudder, aileron and elevator channels to their neutral positions. Channel 5 should be set to your preferred position if you have chosen to utilize it.

The following steps outline the binding process:

- Each time the transmitter is turned on, it enters “Bind Mode” for a few seconds. You can tell that the transmitter is in bind mode when you see the red LED located under the door on the bottom left front of the transmitter blink rapidly. Once the LED becomes solid, the transmitter is no longer in bind mode and will transmit normally.



Note: For safety, disconnect both main motor plugs from the 4-in-1 control unit (as shown on page 16) before proceeding. Once the binding process is complete and the flight battery is unplugged from the 4-in-1 unit, reconnect the main motor plugs to 4-in-1 unit (as noted on page 19).

- In order to bind the 4-in-1 control unit's receiver to the transmitter, you must first insert the Bind Plug (included with your Blade™ CX2 and replacement 4-in-1 control units) into the "BAT" opening on the receiver. Then you will need to power on the 4-in-1 control unit by connecting the flight battery BEFORE powering the transmitter on.



- When you connect the flight battery to the 4-in-1 unit with the bind plug inserted into the "BAT" opening on the receiver, you will see an orange LED blink rapidly on the receiver itself.
- Once the orange LED on the receiver begins to blink, turn on the transmitter. The transmitter will immediately enter bind mode. Then, once the orange LED on the receiver and the red LED on the transmitter turn solid, the 4-in-1 unit's receiver is bound to the transmitter. Now you will need to power down the 4-in-1 control unit and transmitter, and remove the bind plug from the receiver.

Note: It is extremely important that you remove the bind plug from the receiver once it has been bound to the transmitter. If you do not remove the bind plug, the receiver will enter bind mode every time the 4-in-1 unit is powered on.

Main Motor Care and Installing the Optional Main Motor Heat Sink

The 180 motors used to power your Blade™ CX2 are of the closed endbell variety and do not require any special maintenance. We do, however, suggest that you allow the motors to cool to near ambient temperature between flights/battery pack changes to prevent accelerated motor wear due to excess motor heat.

You will find the performance and life of the 180 main motors to be very good, however, installation of the optional Main Motor Heat Sink (EFLH1208) can help to further improve motor cooling during flight, resulting in improved motor performance and longer motor life.

Installing the main motor heat sink takes only a few minutes following these steps:

- Installation of the main motor heat sink will require that you temporarily remove the right-hand main motor from the main frame. This is easily accomplished by removing the two motor mounting screws found on the bottom of the main frame.



- With the right-hand main motor removed from the frame, you can press the main motor heat sink into place near the top/end of the left-hand main motor. We recommend that you use Heat Sink Compound (EFLM1913) on any surfaces of the heat sink that make contact with the motor case to further improve the effectiveness of the heat sink. The wider end of the heat sink (more fins) must be placed toward the front of the helicopter.

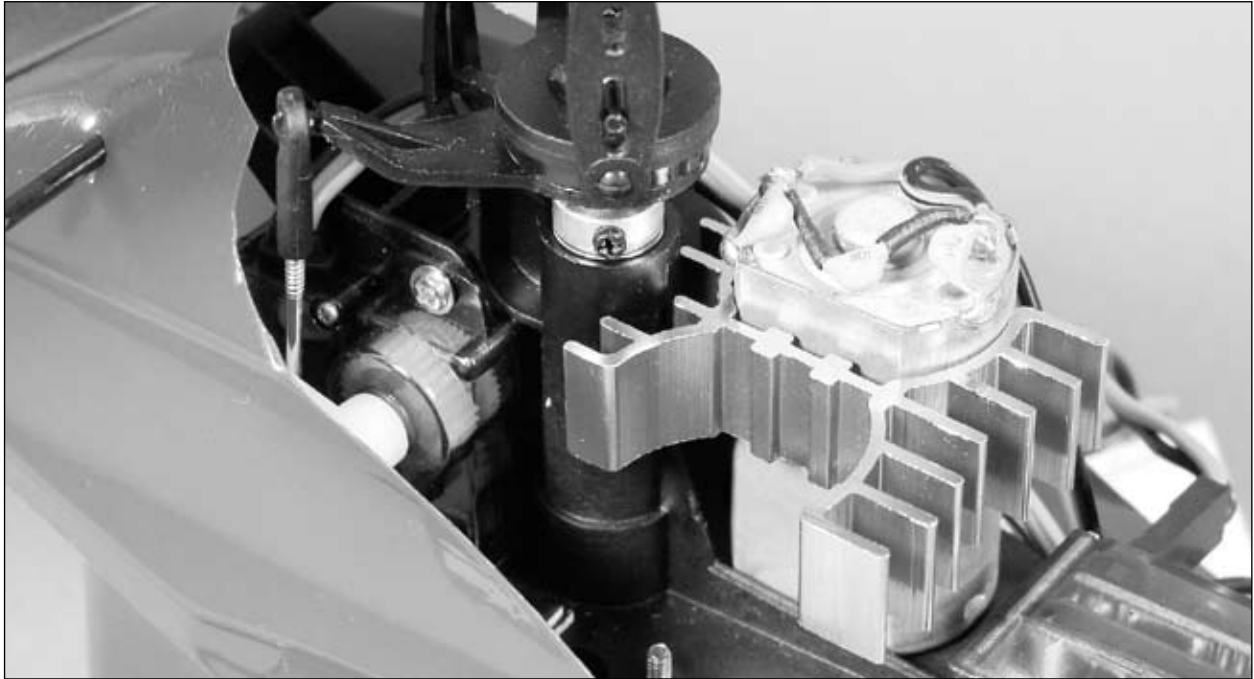

- You can now press the right-hand main motor into place in the heat sink and use the motor mounting screws to re-install the motor on the main frame. Again, we recommend that you use Heat Sink Compound (EFLM1913) on any surfaces of the heat sink that make contact with the motor case to further improve the effectiveness of the heat sink.



The main motor heat sink is now installed and ready for flight.

2006 Official AMA National Model Aircraft Safety Code

GENERAL

- 1) I will not fly my model aircraft in sanctioned events, air shows or model flying demonstrations until it has been proven to be airworthy by having been previously, successfully flight tested.
- 2) I will not fly my model higher than approximately 400 feet within 3 miles of an airport without notifying the airport operator. I will give right-of-way and avoid flying in the proximity of full-scale aircraft. Where necessary, an observer shall be utilized to supervise flying to avoid having models fly in the proximity of full-scale aircraft.
- 3) Where established, I will abide by the safety rules for the flying site I use, and I will not willfully or deliberately fly my models in a careless, reckless and/or dangerous manner.
- 4) The maximum takeoff weight of a model is 55 pounds, except models flown under Experimental Aircraft rules.
- 5) I will not fly my model unless it is identified with my name and address or AMA number on or in the model. (This does not apply to models while being flown indoors.)
- 6) I will not operate models with metal-bladed propellers or with gaseous boosts, in which gases other than air enter their internal combustion engine(s); nor will I operate models with extremely hazardous fuels such as those containing tetranitromethane or hydrazine.

RADIO CONTROL

- 1) I will have completed a successful radio equipment ground range check before the first flight of a new or repaired model.
- 2) I will not fly my model aircraft in the presence of spectators until I become a qualified flier, unless assisted by an experienced helper.
- 3) At all flying sites a straight or curved line(s) must be established in front of which all flying takes place with the other side for spectators. Only personnel involved with flying the aircraft are allowed at or in front of the flight line. Intentional flying behind the flight line is prohibited.
- 4) I will operate my model using only radio control frequencies currently allowed by the Federal Communications Commission. (Only properly licensed Amateurs are authorized to operate equipment on Amateur Band frequencies.)
- 5) Flying sites separated by three miles or more are considered safe from site-to site interference, even when both sites use the same frequencies. Any circumstances under three miles separation require a frequency management arrangement, which may be either an allocation of specific frequencies for each site or testing to determine that freedom from interference exists. Allocation plans or interference test reports shall be signed by the parties involved and provided to AMA Headquarters. Documents of agreement and reports may exist between (1) two or more AMA Chartered Clubs, (2) AMA clubs and individual AMA members not associated with AMA Clubs, or (3) two or more individual AMA members.
- 6) For Combat, distance between combat engagement line and spectator line will be 500 feet per cubic inch of engine displacement. (Example: .40 engine = 200 feet.); electric motors will be based on equivalent combustion engine size. Additional safety requirements will be per the RC Combat section of the current Competition Regulations.
- 7) At air shows or model flying demonstrations, a single straight line must be established, one side of which is for flying, with the other side for spectators.
- 8) With the exception of events flown under AMA Competition rules, after launch, except for pilots or helpers being used, no powered model may be flown closer than 25 feet to any person.
- 9) Under no circumstances may a pilot or other person touch a powered model in flight.

Replacement Parts List











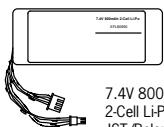
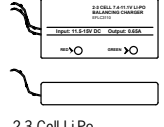
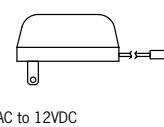
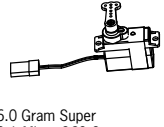

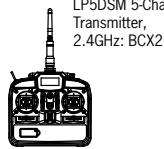
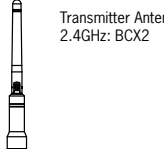

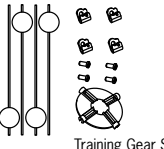
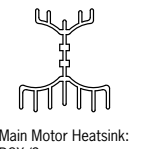
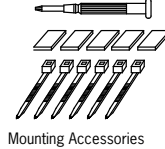
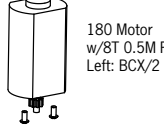
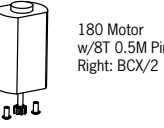
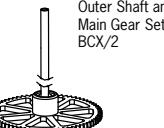
EFLH1250	Blade CX2 RTF Electric Coaxial Heli
EFLB0990	7.4V 800mAh 2-Cell Li-Po, JST/Balance
EFLC3110	2-3 Cell Li-Po Balancing Charger, 0.65A
EFLC4000	AC to 12VDC, 1.5 Amp Power Supply
EFLH1022	Bind Plug: BCX2
EFLH1024	4-in-1 Control Unit, Receiver/ESC/Mixer/Gyro 2.4GHz: BCX2
EFLH1055	LP5DSM 5-Channel Transmitter, 2.4GHz: BCX2
EFLH1058	Transmitter Antenna, 2.4GHz: BCX2
EFLRS60	6.0-Gram Super Sub-Micro S60 Servo
EFLRS601	Gear Set: S60
EFLRS602	Case Set: S60
EFLRSA100	Standard Arm Set, Fine Spline: S60
EFLH1121	Bearing 2x6x3mm (2): BCP, BCX/2
EFLH1209	Mounting Accessories & Screwdriver: BCX/2
EFLH1210	180 Motor w/8T 0.5M Pinion Left: BCX/2
EFLH1211	180 Motor w/8T 0.5M Pinion Right: BCX/2
EFLH1213	Outer Shaft & Main Gear Set: BCX/2
EFLH1214	Shaft Retaining Collar Set: BCX/2
EFLH1215	Bearing 4x6x3mm (2): BCX/2
EFLH1216	Swashplate Set: BCX/2
EFLH1217	Lower Rotor Head & Linkage Set: BCX/2
EFLH1218	Servo Pushrod Set: BCX/2
EFLH1219	Stabilizer Flybar Set: BCX/2
EFLH1220	Lower Main Blade Set (2 pair): BCX/2
EFLH1221	Upper Main Blade Set (2 pair): BCX/2
EFLH1222	Landing Skid Set: BCX/2
EFLH1223	Battery Support Set: BCX/2
EFLH1225	Hardware Set: BCX/2
EFLH1226	Body Mount Rod & Grommet Set: BCX/2
EFLH1242	Inner Shaft w/Head/Hub: BCX/2
EFLH1243	Inner Shaft Main Gear: BCX/2
EFLH1254	Main Frame Set: BCX2
EFLH1255	Front Body/Canopy: BCX2
EFLH1256	Rear Body: BCX2
EFLH1257	Complete Body Set: BCX2

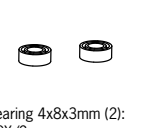
Optional Parts List

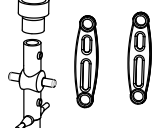
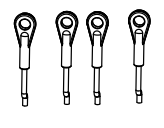
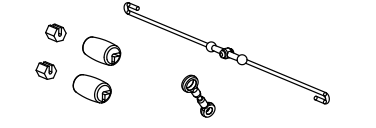
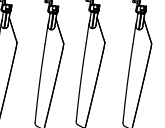
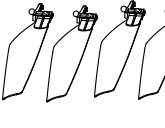
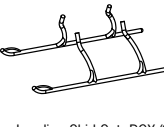
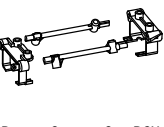
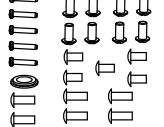
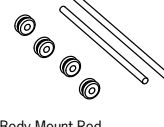
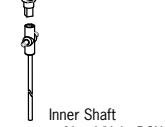
EFLH1205	Training Gear Set: BCX/2
EFLH1208	Main Motor Heat Sink: BCX/2
EFLM1913	Heat Sink Compound, 5g
EFLH1227	Front Body, Yellow: BCX
EFLH1228	Rear Body, Yellow: BCX
EFLH1229	Complete Body Set, Yellow: BCX
EFLH1230	Front Body, Police, Blue: BCX/2
EFLH1231	Rear Body, Police, Blue: BCX/2
EFLH1232	Complete Body Set, Police, Blue: BCX/2
EFLH1240	Inner Shaft w/Aluminum Head/Hub: BCX/2
EFLH1241	Inner Shaft for Aluminum Head/Hub: BCX/2
EFLH1244	Aluminum Bearing Holder w/Bearing: BCX/2
EFLH1245	Aluminum Lower Rotor Head Set: BCX/2
EFLH1246	Aluminum Swashplate Set: BCX/2
EFLH1258	Front Body, Marines w/o Decals: BCX/2
EFLH1259	Rear Body, Marines w/o Decals: BCX/2
EFLH1260	Complete Body Set, Marines w/Decals/Gun/Missiles: BCX/2
EFLH1261	Decal Set, Marines: BCX/2
EFLH1262	Gun and Missile Set: BCX/2

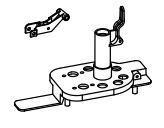
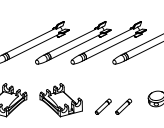
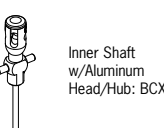
Please see your favorite retailer or visit our web site (www.E-fliteRC.com) to find the latest in new replacement and option parts releases for your Blade CX2.

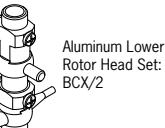
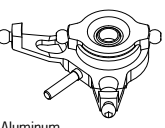
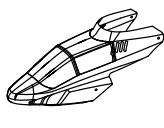
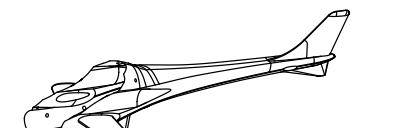
Replacement and Optional Parts

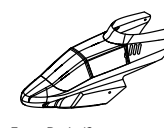
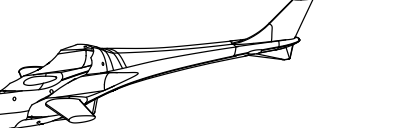
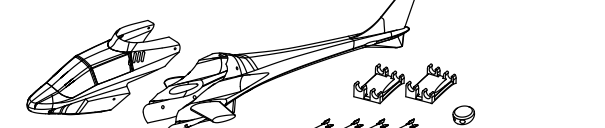
 <p>7.4V 800mAh 2-Cell Li-Po, JST/Balance</p> <p>EFLB0990</p>	 <p>2-3 Cell Li-Po Balancing Charger, 0.65A</p> <p>EFLC3110</p>	 <p>AC to 12VDC 1.5 Amp Power Supply</p> <p>EFLC4000</p>	 <p>6.0 Gram Super Sub-Micro S60 Servo</p> <p>EFLRS60</p>	 <p>Bind Plug: BCX2</p> <p>EFLH1022</p>	 <p>4-in-1 Control Unit, Receiver/ESC/Mixer/Gyro 2.4GHz: BCX2</p> <p>EFLH1024</p>
 <p>LP5DSM 5-Channel Transmitter, 2.4GHz: BCX2</p> <p>EFLH1055</p>	 <p>Transmitter Antenna, 2.4GHz: BCX2</p> <p>EFLH1058</p>	 <p>Bearing 2x6x3mm (2): BCP/P, BCX2</p> <p>EFLH1121</p>	 <p>Training Gear Set: BCX/2</p> <p>EFLH1205</p>	 <p>Main Motor Heatsink: BCX/2</p> <p>EFLH1208</p>	 <p>Mounting Accessories and Screwdriver: BCX/2</p> <p>EFLH1209</p>
 <p>180 Motor w/8T 0.5M Pinion Left: BCX/2</p> <p>EFLH1210</p>	 <p>180 Motor w/8T 0.5M Pinion Right: BCX/2</p> <p>EFLH1211</p>	 <p>Outer Shaft and Main Gear Set: BCX/2</p> <p>EFLH1213</p>	 <p>Shaft Retaining Collar Set: BCX/2</p> <p>EFLH1214</p>	 <p>Bearing 4x8x3mm (2): BCX/2</p> <p>EFLH1215</p>	 <p>Swashplate Set: BCX/2</p> <p>EFLH1216</p>
 <p>Lower Rotor Head and Linkage Set: BCX/2</p> <p>EFLH1217</p>	 <p>Servo Pushrod Set: BCX/2</p> <p>EFLH1218</p>	 <p>Stabilizer Flybar Set: BCX/2</p> <p>EFLH1219</p>		 <p>Lower Main Blade Set (2 pair): BCX/2</p> <p>EFLH1220</p>	 <p>Upper Main Blade Set (2 pair): BCX/2</p> <p>EFLH1221</p>
 <p>Landing Skid Set: BCX/2</p> <p>EFLH1222</p>	 <p>Battery Support Set: BCX/2</p> <p>EFLH1223</p>	 <p>Hardware Set: BCX/2</p> <p>EFLH1225</p>	 <p>Body Mount Rod and Grommet Set: BCX/2</p> <p>EFLH1226</p>	 <p>Inner Shaft w/Head/Hub: BCX/2</p> <p>EFLH1242</p>	 <p>Inner Shaft Main Gear: BCX/2</p> <p>EFLH1243</p>
 <p>Main Frame Set: BCX2</p> <p>EFLH1254</p>	 <p>Gun and Missile Set: BCX/2</p> <p>EFLH1262</p>	 <p>Inner Shaft w/Aluminum Head/Hub: BCX/2</p> <p>EFLH1240</p>	 <p>Aluminum Bearing Holder w/Bearing: BCX/2</p> <p>EFLH1244</p>	 <p>Aluminum Lower Rotor Head Set: BCX/2</p> <p>EFLH1245</p>	 <p>Aluminum Swashplate Set: BCX/2</p> <p>EFLH1246</p>
 <p>Front Body/Canopy: BCX2</p> <p>EFLH1255</p>	 <p>Rear Body: BCX/2</p> <p>EFLH1256</p>		 <p>Complete Body Set: BCX/2</p> <p>EFLH1257</p>		
 <p>Front Body/Canopy, Marines w/o Decals: BCX/2</p> <p>EFLH1258</p>	 <p>Rear Body, Marines w/o Decals: BCX/2</p> <p>EFLH1259</p>		 <p>Complete Body Set, Marines w/Decals/Gun/Missiles: BCX/2</p> <p>EFLH1260</p>		

Exploded View Parts Listing

Exploded View Reference Number	Description (Quantity Required)	Included In Item Number
001	Stabilizer Flybar Rubber Tip (2)	EFLH1219
002	Stabilizer Flybar Weight (2)	EFLH1219
003	Stabilizer Flybar (1)	EFLH1219
004	Upper Main Blade (2)	EFLH1221
005	1.2 x 6mm Screw (5)	EFLH1225
006	Stabilizer Flybar Hub/Holder (1)	EFLH1242
007	Upper Rotor Head & Inner Shaft (1)	EFLH1242
008	Stabilizer Flybar Linkage (1)	EFLH1219
009	Bearing 2mm x 6mm x 3mm (2)	EFLH1121
010	Bearing Holder (1)	EFLH1217
011	Outer Shaft (1)	EFLH1213
012	Lower Rotor Head (1)	EFLH1217
013	M2 x 2.5mm Screw (5)	EFLH1225
014	Lower Main Blade (2)	EFLH1220
015	Lower Rotor Head/Swash Linkage (2)	EFLH1217
016	Upper Swashplate (1)	EFLH1216
017	Bearing 7mm x 13mm x 4mm (1)	EFLH1216
018	Lower Swashplate (1)	EFLH1216
019	Servo Pushrod Control Link (2)	EFLH1218
020	Outer Shaft Retaining Collar (1)	EFLH1214
021	Main Motor Left (1)	EFLH1210
	Main Motor Right (1)	EFLH1211
022	Pinion Gear Left (1)	EFLH1210
	Pinion Gear Right (1)	EFLH1211
023	Servo Mount (1)	EFLH1254
024	Body Mount Rod (2)	EFLH1226
025	Super Sub-Micro Servo (2)	EFLRS60
026	1.7 x 4mm Screw (8)	EFLH1225
027	Bearing 4mm x 8mm x 3mm (2)	EFLH1215
028	Servo Pushrod (2)	EFLH1218
029	4-in-1 Control Unit (1)	EFLH1024
030	Main Frame (1)	EFLH1254
031	M2 x 4mm Screw (6)	EFLH1225
032	Front Body (1)	EFLH1255
033	Rear Body (1)	EFLH1256
034	Outer Shaft Main Gear (1)	EFLH1213
035	Inner Shaft Main Gear (1)	EFLH1243
036	Inner Shaft Retaining Collar (1)	EFLH1214
037	Battery Support Rear (1)	EFLH1223
038	Battery Support Front (1)	EFLH1223
039	Battery Support Joiner (2)	EFLH1223
040	Body Mount Grommet (4)	EFLH1226
041	Battery Pack (1)	EFLB0990
042	Landing Skid Right (1)	EFLH1222
043	Landing Skid Left (1)	EFLH1222
044	Step Washer (1)	EFLH1225

Please see your favorite retailer or visit our web site (www.E-fliteRC.com) to find the latest in new replacement and option parts releases for your Blade CX2.

Exploded View

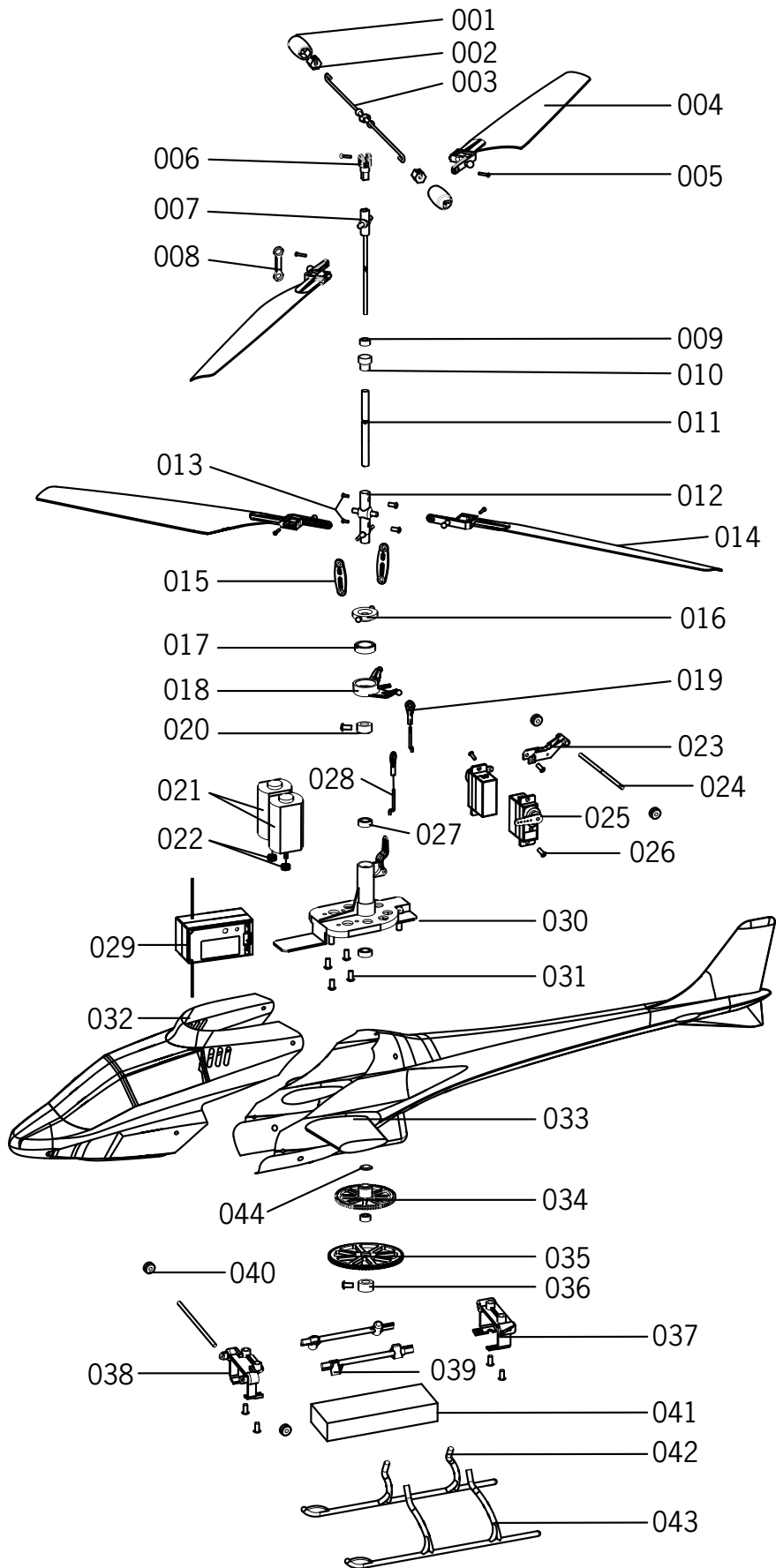



© 2006 Horizon Hobby, Inc.
4105 Fieldstone Road
Champaign, Illinois 61822
(877) 504-0233
www.E-fliteRC.com