

# **BLADE<sup>®</sup>**

**CG02 GB 3-Axis  
Brushless Camera/  
Gimbal**

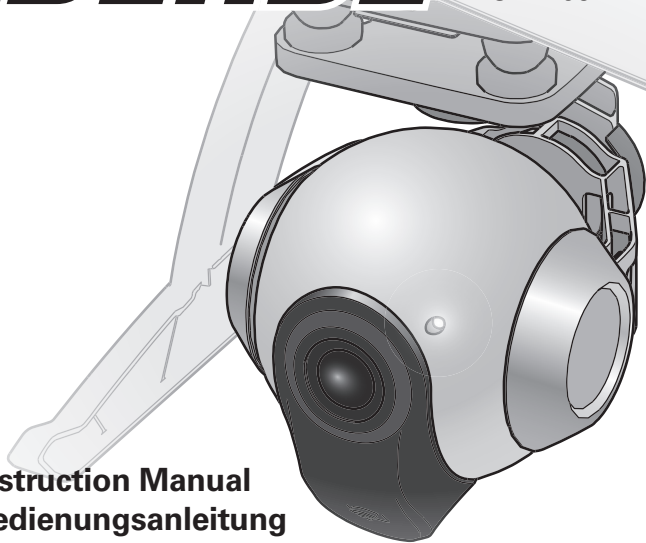

**Instruction Manual  
Bedienungsanleitung  
Manuel d'utilisation  
Manuale di Istruzioni**

## NOTICE

All instructions, warranties and other collateral documents are subject to change at the sole discretion of Horizon Hobby, LLC. For up-to-date product literature, visit [horizonhobby.com](http://horizonhobby.com) and click on the support tab for this product.

## Meaning of Special Language

The following terms are used throughout the product literature to indicate various levels of potential harm when operating this product:

**NOTICE:** Procedures, which if not properly followed, create a possibility of physical property damage AND a little or no possibility of injury.

**CAUTION:** Procedures, which if not properly followed, create the probability of physical property damage AND a possibility of serious injury.

**WARNING:** Procedures, which if not properly followed, create the probability of property damage, collateral damage, and serious injury OR create a high probability of superficial injury.



**WARNING:** Read the ENTIRE instruction manual to become familiar with the features of the product before operating. Failure to operate the product correctly can result in damage to the product, personal property and cause serious injury.

This is a sophisticated hobby product. It must be operated with caution and common sense and requires some basic mechanical ability. Failure to operate this Product in a safe and responsible manner could result in injury or damage to the product or other property. This product is not intended for use by children without direct adult supervision. Do not use with incompatible components or alter this product in any way outside of the instructions provided by Horizon Hobby, LLC. This manual contains instructions for safety, operation and maintenance. It is essential to read and follow all the instructions and warnings in the manual, prior to assembly, setup or use, in order to operate correctly and avoid damage or serious injury.

**Age Recommendation: Not for children under 14 years. This is not a toy.**

## Safety Precautions and Warnings

---

- Always keep a safe distance in all directions around your model to avoid collisions or injury. This model is controlled by a radio signal subject to interference from many sources outside your control. Interference can cause momentary loss of control.
- Always operate your model in open spaces away from full-size vehicles, traffic and people.
- Always carefully follow the directions and warnings for this and any optional support equipment (chargers, rechargeable battery packs, etc.).
- Always keep all chemicals, small parts and anything electrical out of the reach of children.
- Always avoid water exposure to all equipment not specifically designed and protected for this purpose. Moisture causes damage to electronics.
- Never place any portion of the model in your mouth as it could cause serious injury or even death.
- Never operate your model with low transmitter batteries.
- Always keep the aircraft in sight and under control.
- Always move the throttle fully down at rotor strike.
- Always use fully charged batteries.
- Always keep the transmitter powered on while the aircraft is powered.
- Always remove batteries before disassembly
- Always keep moving parts clean.
- Always keep parts dry.
- Always let parts cool after use before touching.
- Always remove batteries after use.
- Never operate an aircraft with damaged wiring.
- Never touch moving parts.

## Table of Contents

Box Contents .....	4	Transmitter Programming .....	10
Technical Specifications.....	5	Using the Gimbal .....	10
Loading the CGO2 App to Your WiFi Smart Device.....	5	Using the CGO2 App.....	11
Gimbal Components.....	6	LED Codes .....	11
Installing the Mounting Plate.....	7	Troubleshooting .....	12
Installing the Gimbal.....	7	Replacement Parts.....	12
Routing the Wiring .....	8	Service Contact Information .....	13
Connecting the Gimbal.....	9		

## Box Contents

- A. CGO2 GB 3-Axis Camera/Gimbal
- B. Mounting plate
- C. (3) M2.5 x 10  
Mounting Screws

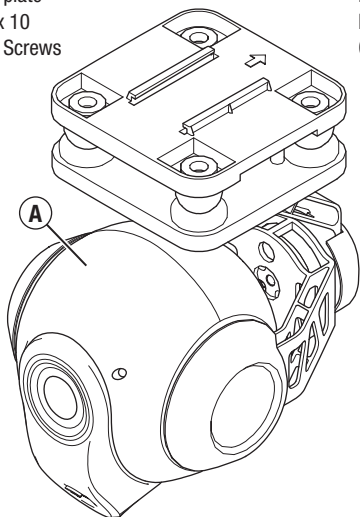

- D. 3-wire signal lead
- E. 2-wire power lead
- F. 4 pin Y-harness (not used)
- G. 4-pin to servo harness (not used)

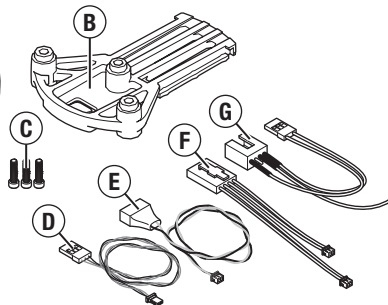

## Technical Specifications

---

Dimensions LxWxH (with lens):	3.00 x 101.62 x 129.12mm	
Weight:	163 g	
Working Voltage:	12V	
Wireless Frequency Range:	5745MHz–5825MHz	
Lens Sensor:	16M	
Angle of view:	155°	
Controlled Rotation Range:	Pitch Axis Control:	–90°–0°
Effective Pixels:	16 million	
White Balance:	Automatic	
Focusing System:	Fixed	
Storage Temperature:	–20°–60°C	
Working Temperature:	0°–50°C	

## Loading the CGO2 App to Your WiFi Smart Device

---

- Download the free CGO2 GB App to your smartphone or tablet at the iTunes App Store or Google Play Store.
- Install the app to your 5.8GHz WiFi capable device.
- Make a note of the network name and password key located on the top of the gimbal assembly.

# Gimbal Components

Front

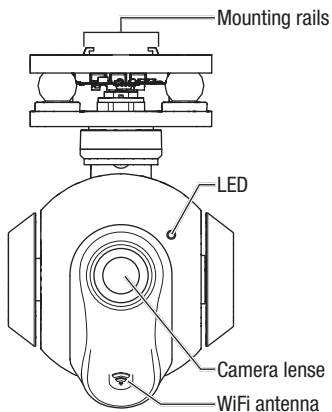

Bottom

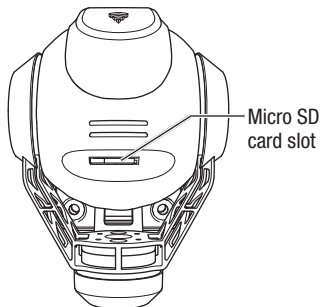

Left side

YUNEEC satellite receiver port

12V gimbal power port

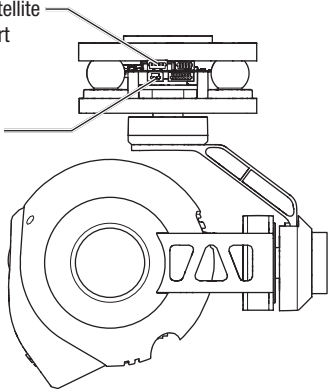

Right side

PWM ports

UART code update port

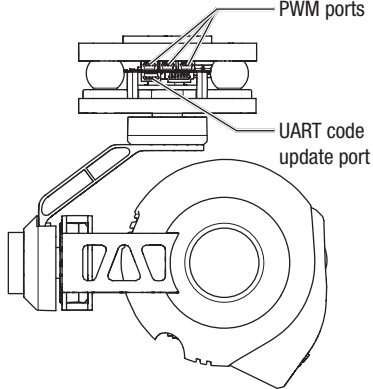

## Installing the Mounting Plate

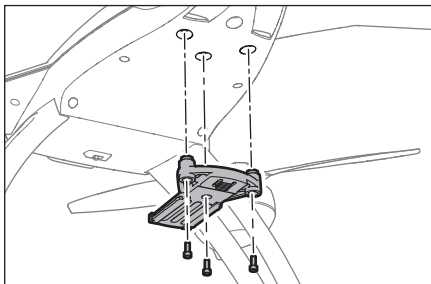

Install the mounting plate using the 3 included M2.5 x 10 screws. Do not overtighten.

**IMPORTANT:** The CG02 GB requires the use of the Blade 350 QX2 body set and tall landing gear. If you wish to install the CG02 GB on a 350 QX, you must first install BLH7811A (body set) and BLH7815TGA (tall landing gear).

## Installing the Gimbal

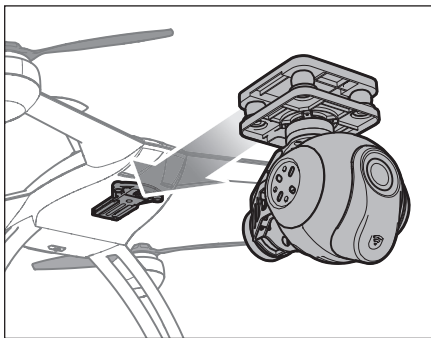

Install the gimbal by lining up the tracks of the gimbal and the mount and pushing towards the rear of the plate until it locks into place as shown at left.

To remove the gimbal, push in the retaining clip at the front of the mounting plate and pull the gimbal forward.

## Routing the Wiring

There are two leads included with the CGO2 GB gimbal:

- 3-wire signal lead with a servo style connector and a 3-pin JST connector.
- 2-wire power lead with a 4-pin balance connector and a 2-pin JST connector.

Route the leads as follows:

1. Plug the servo connector of the signal lead into the rearmost pins on the flight control board as shown at right, with the brown wire toward the outside.
2. Route the JST connector through the hole in the landing gear mount on the bottom of the 350 QX.
3. Route the JST connector of the power lead down through the hole in the opposite gear mount on the bottom of the 350 QX, leaving the balance connector loose inside the battery compartment.

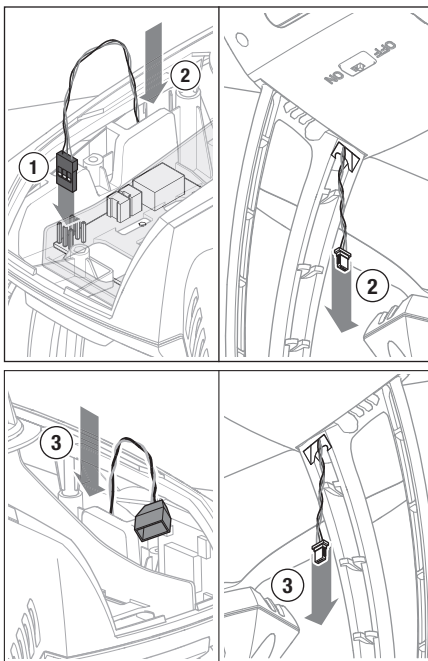



## Connecting the Gimbal

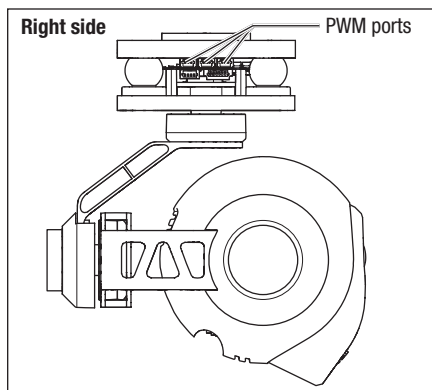

1. Connect the signal lead to any of the 3 available PWM ports on the right side of the gimbal assembly.
2. Connect the power lead to the 12V gimbal power port on the left side of the gimbal assembly.

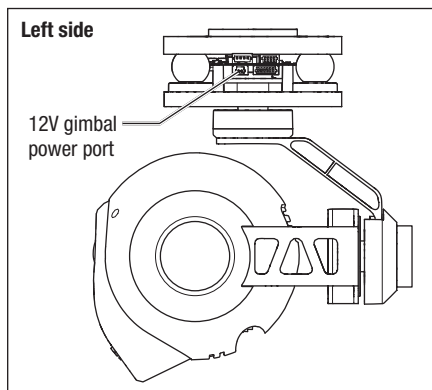

## Transmitter Programming

---

Transmitter control of the pitch angle of the CG02 GB is possible with most 6-channel and above Spektrum transmitters. Control of the pitch angle in flight is achieved on the DX6i and DX6 by temporarily using the throttle control stick to adjust pitch. If you are using the DX7s, DX8, DX9 or DX18, pitch control is achieved via the rotary knob on your transmitter.

*To program your transmitter:*

### DX6i

- Set the Channel 6 (FLAP) Travel Adj. to 120 up and 100 down.
- Set the values in the FLAP menu to 100 up and 100 down.

To change gimbal angle **BEFORE** starting the motors for flight, set the flap switch to position 1. The throttle stick will now control the angle of the gimbal. Set the flap switch to position 0 before flight.

To change the gimbal angle **IN FLIGHT**, cycle the flap switch to position 1. The throttle stick will now control the gimbal angle for **approximately 5 seconds** before returning to throttle control. Return the flap switch to position 0.

### DX6

In Channel Input Configuration:

- Assign channel 6 (AUX1) to switch A.
- Assign Gear to switch B.

In Servo Setup:

- Reverse the travel for AUX1.
- Set the travel values for AUX1 to:  
120%  
140%

To change the gimbal angle **BEFORE** starting the motors for flight, set switch A to position 1. The throttle stick will now control the angle of the gimbal. Set switch A to position 0 before flight.

To change the gimbal angle **IN FLIGHT**, cycle switch A to position 1. The throttle stick will now control the gimbal angle for **approximately 5 seconds** before returning to throttle control. Return switch A to position 0.

### DX7s

In Channel Input Configuration:

- Assign Channel 7 Input (AUX2) to the rotary knob.
- Assign AUX1 to the Gear switch.

In Servo Setup:

- Set the Channel 6 (AUX1) travel to the values below:  
120%  
140%

To change the gimbal angle, set the gear switch to position 0 and adjust the angle of the gimbal by rotating the knob on your transmitter at any time.

### DX8

In Channel Input Configuration:

- Assign Channel 7 Input (AUX2) to the rotary knob.
- Assign AUX1 to the Gear switch.

In Servo Setup:

- Set the Channel 6 (AUX1) travel to the values below:  
120  
140

To change the gimbal angle, set the gear switch to position 0 and adjust the angle of the gimbal by rotating the knob on your transmitter at any time.

---

## DX9, DX18

In Channel Input Configuration:

- Assign Channel 7 Input (AUX2) to R Knob.
- Assign AUX1 to A.

In Servo Setup:

- Set the AUX1 travel to the values below:  
140  
120

To change the gimbal angle, set switch A to position 0 and adjust the angle of the gimbal by rotating the R Knob at any time.

---

## Using the Gimbal

1. Insert the micro SD card into the slot on the bottom of the camera.
2. Place the quadcopter on a flat and stable surface. Ensure there are no obstructions in the path of the CGO2 GB.
3. Switch on your transmitter.
4. Plug the balance connector of the power lead into the balance lead of the quadcopter battery.
5. Switch on your quadcopter.

After the CGO2 GB powers on, the LED will glow red for approximately 40 seconds while the gimbal initializes. When the LED changes to green the CGO2 is ready to connect via WiFi.

See the “Using the CGO2 App” section for instructions on how to connect your gimbal to your smart device and for a description of the camera controls available. The gimbal will now compensate for any roll, pitch and yaw movements encountered by your quadcopter in flight.

If desired, you may change the pitch angle of the gimbal at any time using your programmed transmitter controls.

## Using the CGO2 App

- With the CGO2 GB powered on, open the Wi-Fi settings on your smartphone or tablet and connect to the CGO2 GB network (CGO2 GB\_\*\*\*\*\*) using the password “1234567890”.
- Open the CGO2 GB App on your device.

You can now take still photos or start/stop recording video by using the buttons shown at right.

It is possible to take still photos at any time, even while you are recording live video.

Be sure to check for updates to the CGO2 App in the iTunes App Store, or Google Play Store.

### CGO App Controls

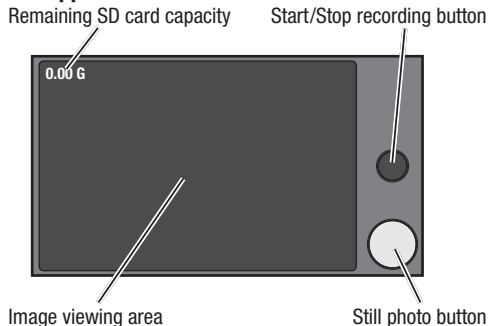

## LED Codes

Initializing.....	.....
Ready to connect to WiFi.....	.....
Video recording.....	.....
SD card error.....	.....
WiFi error.....	.....

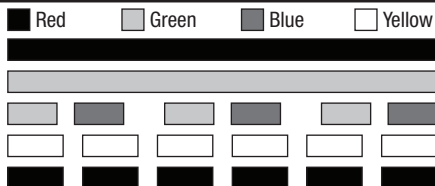

## Troubleshooting

Problem	Possible Cause	Solution
The gimbal vibrates after switching ON	Gimbal did not initialize correctly or was obstructed	Re-initialize with the gimbal clear of obstructions
Gimbal does not respond to control input	Gimbal did not initialize	Keep the quadcopter and gimbal level and immobile for 5 seconds after switching ON
Gimbal is not ON	Incorrect gimbal connections	Correctly connect gimbal
Gimbal does not respond to transmitter	Incorrect transmitter set up	Review transmitter programming section and make corrections to transmitter set up
Gimbal does not respond to control inputs. RED and BLUE LEDs are solid	Incorrect gimbal connections	Correctly connect gimbal
Gimbal is not ON and RED LED flashes slowly	Gimbal gyro board damage	Contact Horizon Product Support
Gimbal LED Flashing RED in Angle or Velocity Mode	Sensor Error	Check for correct gimbal connection or contact Horizon Product Support

## Replacement Parts

Part #	Description
BLH8106	Mounting Hardware: C-Go2GB

## Optional Parts

Part #	Description
BLH7811A	Body Set with Hardware: 350 QX
BLH7815TGA	Tall Landing Gear Set: 350 QX2 AP

## Service Contact Information

Country of Purchase	Horizon Hobby	Contact Information	Address
United States of America	Horizon Service Center (Repairs and Repair Requests)	servicecenter.horizonhobby.com/RequestForm/	4105 Fieldstone Rd Champaign, Illinois, 61822 USA
	Horizon Product Support (Product Technical Assistance)	www.quickbase.com/db/bghj7ey8c?a=GenNewRecord 888-959-2304	
	Sales	sales@horizonhobby.com 888-959-2304	
United Kingdom	Service/Parts/Sales: Horizon Hobby Limited	sales@horizonhobby.co.uk +44 (0) 1279 641 097	Units 1–4 , Ployters Rd, Staple Tye Harlow, Essex, CM18 7NS, United Kingdom
Germany	Horizon Technischer Service Sales: Horizon Hobby GmbH	service@horizonhobby.de +49 (0) 4121 2655 100	Christian-Junge-Straße 1 25337 Elmshorn, Germany
France	Service/Parts/Sales: Horizon Hobby SAS	infofrance@horizonhobby.com +33 (0) 1 60 18 34 90	11 Rue Georges Charpak 77127 Lieusaint, France
China	Service/Parts/Sales: Horizon Hobby – China	info@horizonhobby.com.cn +86 (021) 5180 9868	Room 506, No. 97 Changshou Rd. Shanghai, China 200060

©2014 Horizon Hobby, LLC.

Blade is a registered trademarks of Horizon Hobby, LLC.

Yuneeec is a trademark of Yuneeec International Co., Ltd.

All other trademarks, service marks or logos are property of their respective owners.

Patents pending.

Created 12/14 46791.1 BLH8110