

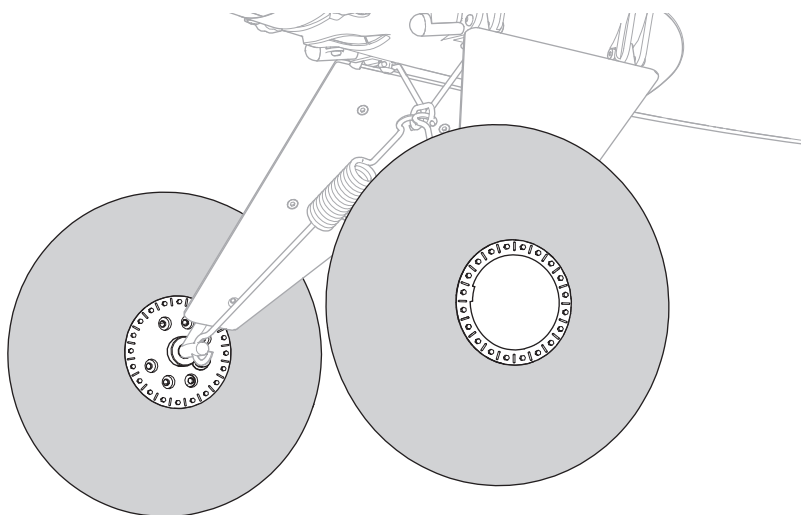

# Inflatable Tundra Tire and Beadlock Wheel Set w/Pump, 5.5" (140mm)



Instruction Manual  
Bedienungsanleitung  
Manuel d'utilisation  
Manuale di Istruzioni

828550.2 Updated 3/24

**HORIZON**<sup>®</sup>  
H O B B Y

**NOTICE**

All instructions, warranties and other collateral documents are subject to change at the sole discretion of Horizon Hobby, LLC. For up-to-date product literature, visit [horizonhobby.com](http://horizonhobby.com) or [towerhobbies.com](http://towerhobbies.com) and click on the support or resources tab for this product.

**MEANING OF SPECIAL LANGUAGE**

The following terms are used throughout the product literature to indicate various levels of potential harm when operating this product:

**WARNING:** Procedures, which if not properly followed, create the probability of property damage, collateral damage, and serious injury OR create a high probability of superficial injury.

**CAUTION:** Procedures, which if not properly followed, create the probability of physical property damage AND a possibility of serious injury.

**NOTICE:** Procedures, which if not properly followed, create a possibility of physical property damage AND little or no possibility of injury.



**WARNING:** Read the ENTIRE instruction manual to become familiar with the features of the product before operating. Failure to operate the product correctly can result in damage to the product, personal property and cause serious injury.

This is a sophisticated hobby product. It must be operated with caution and common sense and requires some basic mechanical ability. Failure to operate this Product in a safe and responsible manner could result in injury or damage to the product or other property. This product is not intended for use by children without direct adult supervision. Do not use with incompatible components or alter this product in any way outside of the instructions provided by Horizon Hobby, LLC. This manual contains instructions for safety, operation and maintenance. It is essential to read and follow all the instructions and warnings in the manual, prior to assembly, setup or use, in order to operate correctly and avoid damage or serious injury.

**Age Recommendation: Not for children under 14 years. This is not a toy.**

**Specifications**

<b>Aircraft Weight</b>	Up to 10–12 pounds (4.5–5.4 kg) ready to fly
<b>Diameter</b>	5.5" (140mm; or minimum 5.0"/127mm to maximum 5.75"/146mm)
<b>Axle Diameter</b>	5mm wheel hub, plus adapters/bushings to fit 4mm and 3mm axles
<b>Hub Width</b>	1.1" (27.5mm)
<b>Hub Diameter</b>	1.6" (40mm)
<b>Wheel Weight</b>	3.6oz (102g) without hubcaps, 3.7oz (106g) with hubcaps
<b>Air Valve</b>	Sports ball inflation valve
<b>Included</b>	2- Inflatable Tundra Tires 2- Beadlock Wheels 2- Wheel hubcaps 2- 3mm Axle adapters/bushings 2- 4mm Axle adapters/bushings 12- Wheel hub locking screws 2- Rubber Valve Plug
<b>Tools</b>	1.5mm hex driver Small flat-head screwdriver
<b>Max Pressure</b>	3 psi (140mm diameter)

**Tire Pressure and Diameter**

Inflating the tires will increase the tire diameter, reducing pressure will reduce the diameter. We recommend inflating the tires to 5.5" (140mm) for most applications. Or inflate to a minimum of 5.0" (127mm) or a maximum of 5.75" (146mm) for other applications. Use lower tire pressure for rough surfaces, and higher tire pressure for smooth surfaces.

**Inflating and Deflating the Tires**

Attach the included air hose extension to the air pump. Screw the needle into the end of the air hose. Wet the needle before inserting it into the air valve in the wheel hub for inflation. Do not inflate the tires beyond 5.75" (146mm) diameter (3psi max). The tire pressure is too low to measure with most bicycle or automotive tire pressure gauges. Low pressure gauges for sports balls have the correct range and are available at sporting goods stores. Insert the needle for pumping into the air valve without the pump to reduce tire pressure. Air will immediately be released from the tire.

## Installation

1. Remove existing wheels/tires from airplane axles.
2. For 3mm or 4mm axles select the appropriate axle adapters. Slide the axle adapter onto the axle if required. The wheel hubs fit a 5mm axle without an adapter.
3. Slide wheel onto the axle.
4. Use your existing wheel collars to secure the wheel to the axle.
5. Hubcaps are optional. If you intend to use the hubcaps, the axles cannot extend past the outer wheel hub. Spacers, or a modification to the shorten the axles may be required to use the hubcaps. After verifying the axle will not interfere with the hubcap, press and snap the hubcap onto the outer wheel hub.

## Replacing or Repairing the Tire

In the event of severe damage, replacement tires are available (EFL-1333, EFL-1393 tire only).

Minor repairs can be made with an inner tube repair kit.

To replace or repair the tire:

1. Insert a small flat-head screwdriver into the hubcap slot and carefully pop the hubcap from the wheel.
2. Remove the wheel collar from the axle.
3. Use a 1.5mm hex driver to remove the beadlock wheel hubs.
4. Replace the tire, and/or inflation valve as required for your repair.
5. Tighten each beadlock screw in small increments alternating evenly across each of the screws.

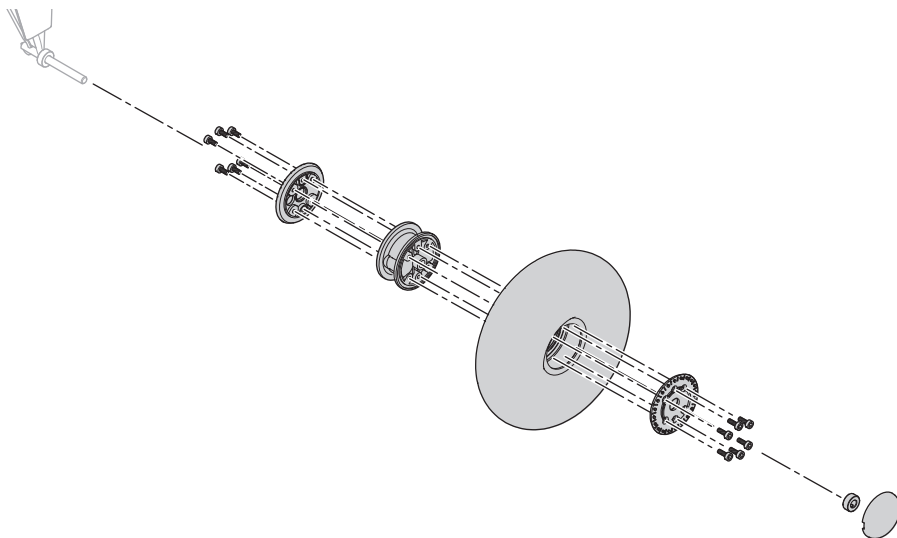

## Replacement parts

EFL-1333	Replacement Inflatable Tundra Tire Set, 5.5" (140mm)
EFL-1349	Air Pump and Air Needle, Inflatable Tundra Tires
EFL-1385	Tundra Beadlock Hubcaps, Locking Screws, Axle Adapters, Rubber Valve Plug
EFL-1393	Tundra Inflatable Replacement Rubber Tire

## Limited Warranty

### What this Warranty Covers

Horizon Hobby, LLC, (Horizon) warrants to the original purchaser that the product purchased (the "Product") will be free from defects in materials and workmanship at the date of purchase.

### What is Not Covered

This warranty is not transferable and does not cover (i) cosmetic damage, (ii) damage due to acts of God, accident, misuse, abuse, negligence, commercial use, or due to improper use, installation, operation or maintenance, (iii) modification of or to any part of the Product, (iv) attempted service by anyone other than a Horizon Hobby authorized service center, (v) Product not purchased from an authorized Horizon dealer, (vi) Product not compliant with applicable technical regulations, or (vii) use that violates any applicable laws, rules, or regulations.

OTHER THAN THE EXPRESS WARRANTY ABOVE, HORIZON MAKES NO OTHER WARRANTY OR REPRESENTATION, AND HEREBY DISCLAIMS ANY AND ALL IMPLIED WARRANTIES, INCLUDING, WITHOUT LIMITATION, THE IMPLIED WARRANTIES OF NON-INFRINGEMENT, MERCHANTABILITY AND FITNESS FOR A PARTICULAR PURPOSE. THE PURCHASER ACKNOWLEDGES THAT THEY ALONE HAVE DETERMINED THAT THE PRODUCT WILL SUITABLY MEET THE REQUIREMENTS OF THE PURCHASER'S INTENDED USE.

### Purchaser's Remedy

Horizon's sole obligation and purchaser's sole and exclusive remedy shall be that Horizon will, at its option, either (i) service, or (ii) replace, any Product determined by Horizon to be defective. Horizon reserves the right to inspect any and all Product(s) involved in a warranty claim. Service or replacement decisions are at the sole discretion of Horizon. Proof of purchase is required for all warranty claims. SERVICE OR REPLACEMENT AS PROVIDED UNDER THIS WARRANTY IS THE PURCHASER'S SOLE AND EXCLUSIVE REMEDY.

### Limitation of Liability

HORIZON SHALL NOT BE LIABLE FOR SPECIAL, INDIRECT, INCIDENTAL OR CONSEQUENTIAL DAMAGES, LOSS OF PROFITS OR PRODUCTION OR COMMERCIAL LOSS IN ANY WAY, REGARDLESS OF WHETHER SUCH CLAIM IS BASED IN CONTRACT, WARRANTY, TORT, NEGLIGENCE, STRICT LIABILITY OR ANY OTHER THEORY OF LIABILITY, EVEN IF HORIZON HAS BEEN ADVISED OF THE POSSIBILITY OF SUCH DAMAGES. Further, in no event shall the liability of Horizon exceed the individual price of the Product on which liability is asserted. As Horizon has no control over use, setup, final assembly, modification or misuse, no liability shall be assumed nor accepted for any resulting damage or injury. By the act of use, setup or assembly, the user accepts all resulting liability. If you as the purchaser or user are not prepared to accept the liability associated with the use of the Product, purchaser is advised to return the Product immediately in new and unused condition to the place of purchase.

### Law

These terms are governed by Illinois law (without regard to conflict of law principals). This warranty gives you specific

legal rights, and you may also have other rights which vary from state to state. Horizon reserves the right to change or modify this warranty at any time without notice.

### WARRANTY SERVICES

#### Questions, Assistance, and Services

Your local hobby store and/or place of purchase cannot provide warranty support or service. Once assembly, setup or use of the Product has been started, you must contact your local distributor or Horizon directly. This will enable Horizon to better answer your questions and service you in the event that you may need any assistance. For questions or assistance, please visit our website at [www.horizonhobby.com](http://www.horizonhobby.com), submit a Product Support Inquiry, or call the toll free telephone number referenced in the Warranty and Service Contact Information section to speak with a Product Support representative.

#### Inspection or Services

If this Product needs to be inspected or serviced and is compliant in the country you live and use the Product in, please use the Horizon Online Service Request submission process found on our website or call Horizon to obtain a Return Merchandise Authorization (RMA) number. Pack the Product securely using a shipping carton. Please note that original boxes may be included, but are not designed to withstand the rigors of shipping without additional protection. Ship via a carrier that provides tracking and insurance for lost or damaged parcels, as Horizon is not responsible for merchandise until it arrives and is accepted at our facility. An Online Service Request is available at [http://www.horizonhobby.com/content/service-center\\_render-service-center](http://www.horizonhobby.com/content/service-center_render-service-center). If you do not have internet access, please contact Horizon Product Support to obtain a RMA number along with instructions for submitting your product for service. When calling Horizon, you will be asked to provide your complete name, street address, email address and phone number where you can be reached during business hours. When sending product into Horizon, please include your RMA number, a list of the included items, and a brief summary of the problem. A copy of your original sales receipt must be included for warranty consideration. Be sure your name, address, and RMA number are clearly written on the outside of the shipping carton.

**NOTICE:** Do not ship LiPo batteries to Horizon. If you have any issue with a LiPo battery, please contact the appropriate Horizon Product Support office.

### Warranty Requirements

For Warranty consideration, you must include your original sales receipt verifying the proof-of-purchase date. Provided warranty conditions have been met, your Product will be serviced or replaced free of charge. Service or replacement decisions are at the sole discretion of Horizon.

### Non-Warranty Service

Should your service not be covered by warranty, service will be completed and payment will be required without notification or estimate of the expense unless the expense exceeds 50% of the retail purchase cost. By submitting the item for service you are agreeing to payment of the

service without notification. Service estimates are available upon request. You must include this request with your item submitted for service. Non-warranty service estimates will be billed a minimum of ½ hour of labor. In addition you will be billed for return freight. Horizon accepts money orders and cashier's checks, as well as Visa, MasterCard, American Express, and Discover cards. By submitting any item to Horizon for service, you are agreeing to Horizon's Terms and Conditions found on our website [http://www.horizonhobby.com/content/service-center\\_render-service-center](http://www.horizonhobby.com/content/service-center_render-service-center).

**ATTENTION:** Horizon service is limited to Product compliant in the country of use and ownership. If received, a non-compliant Product will not be serviced. Further, the sender will be responsible for arranging return shipment of the un-serviced Product, through a carrier of the sender's choice and at the sender's expense. Horizon will hold non-compliant Product for a period of 60 days from notification, after which it will be discarded.

10/15

## Warranty and Service Contact Information

Country of Purchase	Horizon Hobby	Contact Information	Address
United States of America	Horizon Service Center (Repairs and Repair Requests)	<a href="http://servicecenter.horizonhobby.com/RequestForm/">servicecenter.horizonhobby.com/RequestForm/</a>	2904 Research Rd Champaign, IL 61822
	Horizon Product Support (Product Technical Assistance)	<a href="mailto:productsupport@horizonhobby.com">productsupport@horizonhobby.com</a> 877-504-0233	
	Sales	<a href="mailto:websales@horizonhobby.com">websales@horizonhobby.com</a> 800-338-4639	
European Union	Horizon Technischer Service	<a href="mailto:service@horizonhobby.eu">service@horizonhobby.eu</a>	Hanskampring 9 D 22885 Barsbüttel, Germany
	Sales: Horizon Hobby GmbH	+49 (0) 4121 2655 100	

## Compliance Information for the European Union



**EU Compliance Statement:**  
**Tundra Beadlock Inflatable Tire Set**  
**(EFL-1350)**

Hereby, Horizon Hobby, LLC declares that the device is in compliance with the following: RoHS 2 Directive 2011/65/EU; RoHS 3 Directive - Amending 2011/65/EU Annex II 2015/863.

The full text of the EU declaration of conformity is available at the following internet address: <https://www.horizonhobby.com/content/support-render-compliance>.



### EU Manufacturer of Record:

Horizon Hobby, LLC  
2904 Research Road  
Champaign, IL 61822 USA

### EU Importer of Record:

Horizon Hobby, GmbH  
Hanskampring 9  
22885 Barsbüttel Germany

### WEEE NOTICE:



This appliance is labeled in accordance with European Directive 2012/19/EU concerning waste of electrical and electronic equipment (WEEE). This label indicates that this product should not be disposed of with household waste. It should be deposited at an appropriate facility to enable recovery and recycling.



© 2024 Horizon Hobby, LLC.

E-flite, and the Horizon Hobby logo are trademarks or registered trademarks of Horizon Hobby, LLC. The Spektrum trademark is used with permission of Bachmann Industries, Inc.

US 8,672,726. US 9,056,667. US 9,753,457. US 10,078,329. US 9,930,567. US 10,419,970.

<https://www.horizonhobby.com>

828550.2