



PROBOAT™
ProBoatModels.com

VELES[®] 29

BRUSHLESS RTR CATAMARAN

PRB08029

Owners Manual • Bedienungsanleitung
Manuel de l'utilisateur • Manuale dell'utente

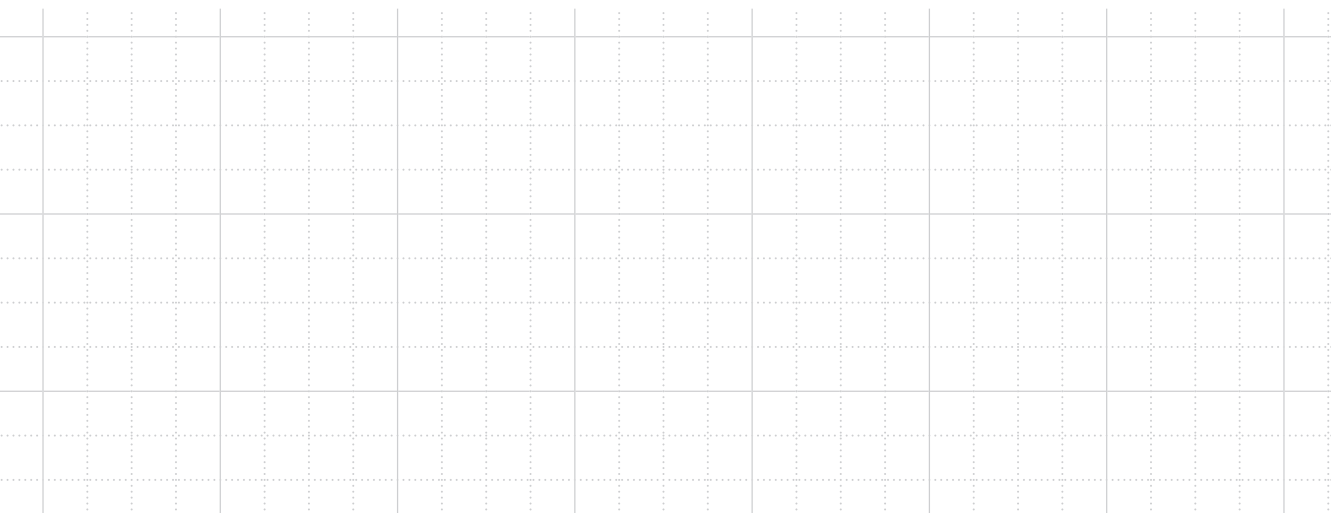
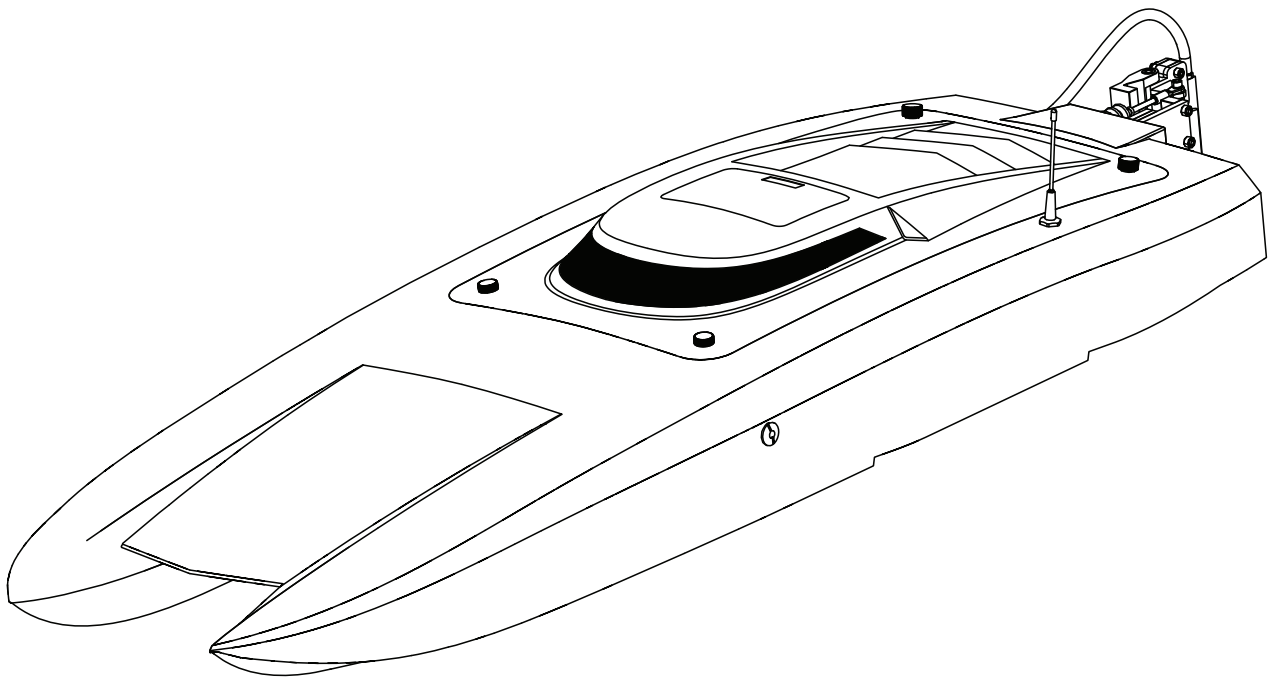

NOTICE

All instructions, warranties and other collateral documents are subject to change at the sole discretion of Horizon Hobby, LLC. For up-to-date product literature, visit www.horizonhobby.com or www.towerhobbies.com and click on the support or resources tab for this product.

MEANING OF SPECIAL LANGUAGE

The following terms are used throughout the product literature to indicate various levels of potential harm when operating this product:

WARNING: Procedures, which if not properly followed, create the probability of property damage, collateral damage, and serious injury OR create a high probability of superficial injury.

CAUTION: Procedures, which if not properly followed, create the probability of physical property damage AND a possibility of serious injury.

NOTICE: Procedures, which if not properly followed, create a possibility of physical property damage AND little or no possibility of injury.



WARNING: Read the ENTIRE instruction manual to become familiar with the features of the product before operating. Failure to operate the product correctly can result in damage to the product, personal property and cause serious injury.

This is a sophisticated hobby product and NOT a toy. It must be operated with caution and common sense and requires some basic mechanical ability. Failure to operate this Product in a safe and responsible manner could result in injury or damage to the product or other property. This product is not intended for use by children without direct adult supervision. Do not use with incompatible components or alter this product in any way outside of the instructions provided by Horizon Hobby, LLC. This manual contains instructions for safety, operation and maintenance. It is essential to read and follow all the instructions and warnings in the manual, prior to assembly, setup or use, in order to operate correctly and avoid damage or serious injury.

Age Recommendation: Not for children under 14 years. This is not a toy.

Safety Precautions and Warnings

As the user of this product, you are solely responsible for operating in a manner that does not endanger yourself and others or result in damage to the product or the property of others.

- When handling and/or transporting your boat, always pick up the boat from the sides, keeping all moving parts pointed away from you.
- Always keep a safe distance in all directions around your model to avoid collisions or injury. This model is controlled by a radio signal subject to interference from many sources outside your control. Interference can cause momentary loss of control.
- Always operate your model in open spaces away from full-size vehicles, traffic and people.

- Always carefully follow the directions and warnings for this and any optional support equipment (chargers, rechargeable battery packs, etc.).
- Always keep all chemicals, small parts and anything electrical out of the reach of children.
- Always avoid water exposure to all equipment not specifically designed and protected for this purpose. Moisture causes damage to unprotected electronics.
- Never place any portion of the model in your mouth as it could cause serious injury or even death.
- Never operate your model with low transmitter batteries.

Table of Contents

Water-Resistant Boat with Waterproof Electronics	3	After Boating and Maintenance.....	10
General Precautions	3	Binding	10
Wet Conditions Maintenance.....	3	Failsafe	10
Specifications	3	Motor Care.....	10
Recommended Tools and Materials	4	Water Cooling System.....	11
Battery Charger	4	Rudder Service.....	11
Boat Stand Assembly	4	Propeller Service.....	11
Antenna Tube Installation.....	4	Propeller Strut Depth Adjustment.....	11
Canopy Removal.....	5	Drivetrain Lubrication	12
Installing the Battery Packs	5	Transmitter Programming	12
Spektrum DX2E Radio System.....	6	Troubleshooting Guide.....	13
Transmitter Battery Installation.....	6	Limited Warranty	14
Battery Charger	6	Warranty and Service Contact Information	15
Low Voltage Cutoff (LVC).....	7	FCC Information	15
Battery Chemistry	7	IC Information.....	15
Getting Started	7	EU Compliance Statement.....	15
Control Check.....	8	Instructions for Disposal of WEEE	15
Testing Your Boat in the Water	8	Replacement Parts	58
Boating Tips	9	Recommended Parts.....	58
When You Are Finished	9	Optional Parts.....	59

Water-Resistant Boat with Waterproof Electronics

Your new Horizon Hobby boat has been designed and built with a combination of waterproof and water-resistant components to allow you to operate the product in calm, fresh water conditions.

While the entire boat is highly water-resistant, it is not completely waterproof and your boat should NOT be treated like a submarine. The various electronic components used in the boat, such as the servo(s) and receiver are waterproof, however, most of the mechanical components are water-resistant and require additional maintenance after use.

Metal parts, including the bearings, pins, screws and nuts, propeller, rudder, rudder mounts, prop struts, as well as the contacts in the electrical cables, will be susceptible to corrosion if additional maintenance is not performed after running in wet conditions. To maximize the long-term performance of your boat and to keep the warranty intact, the procedures described in the “Wet Conditions Maintenance” section must be performed regularly.

CAUTION: Failure to exercise caution while using this product and complying with the following precautions could result in product malfunction and/or void the warranty.

General Precautions

- Read the **WET CONDITIONS MAINTENANCE** procedures and make sure that you have all the tools you will need to properly maintain your boat.
- Not all batteries can be used in wet conditions. Consult the battery manufacturer before use. Caution should be taken when using Li-Po batteries in wet conditions.
- Most transmitters are not water-resistant. Consult your transmitter’s manual or the manufacturer before operation.
- Never operate your transmitter or boat when lightning is present.
- Salt water is very conductive and highly corrosive. If you choose to run your boat in salt water, immediately rinse the boat in fresh water after each use. Operating your boat in salt water is at the sole discretion of the modeler.

Wet Conditions Maintenance

- Drain any water that has collected in the hull by removing the drain plug or canopy and tilting the boat in the appropriate direction to drain the water.

CAUTION: Always keep hands, fingers, tools and any loose or hanging objects away from rotating parts.

- Remove the battery pack(s) and dry the contacts. If you have an air compressor or a can of compressed air, blow out any water that may be inside the recessed connector housings.
- Remove all moving parts. Dry and lubricate parts after every 30 minutes of operation or if the boat becomes submerged.

NOTICE: Never use a pressure washer to clean your boat.

- Use an air compressor or a can of compressed air to dry the boat and help remove any water that may have gotten into small crevices or corners.
- Spray the bearings, fasteners and other metal parts with a water-displacing light oil or lubricant.
- Let the boat air dry before you store it. Water (and oil) may continue to drip for a few hours.

Specifications

Length	29 in (736.6mm)
Height	4.25 in (108mm)
Transmitter	Spektrum™ SLT3 2.4GHz
Receiver	Spektrum™ SR315 3-CH DSMR®
Hull Material	Fiberglass
Motor	2000Kv 6-Pole 3650 Marine Motor (DYNAM3831)
ESC	120A BL Marine ESC 2-6S (DYNAM3875)
Servo	3KG, Plastic Gear Servo, WP, 23T (SPMS603)

Tip: 4 AA batteries (sold separately) are required to operate the transmitter.

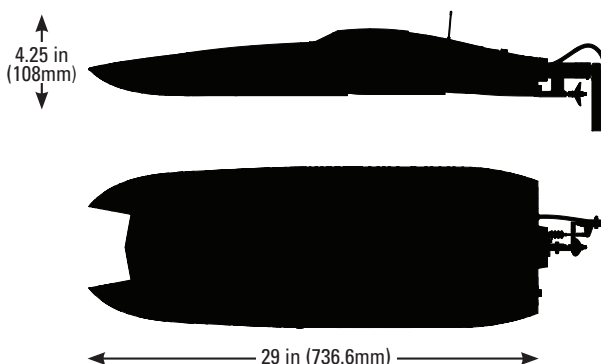

Recommended Tools and Materials

- (2) Spektrum 7.4V 5000mAh 2S 100C Smart Hardcase LiPo Battery: IC5 (SPMX50002S100H5)
-or-
(2) Spektrum 11.1V 5000mAh 3S 100C Smart Hardcase LiPo Battery: IC5 (SPMX50003S100H5)
- Spektrum Smart S2100 AC Charger, 2x100W (SPMXC1010)
- Needle nose pliers
- Paper towel
- Rubbing alcohol
- Open-end wrench: 10mm (2)
- Nut driver: 4mm, 7mm, 8mm
- Phillips screwdriver: #1
- Hex wrench: 1.5mm, 2mm, 2.5mm, 3mm
- Clear tape (DYNM0102)
- Dynamite® Marine Grease and Gun (DYNE4200)
- Hook and Loop Tape Set, WP 4pcs (DYNK0300)
- Dynamite CA Glue Pipettes, Medium .10 oz (3) (DYNK0064)

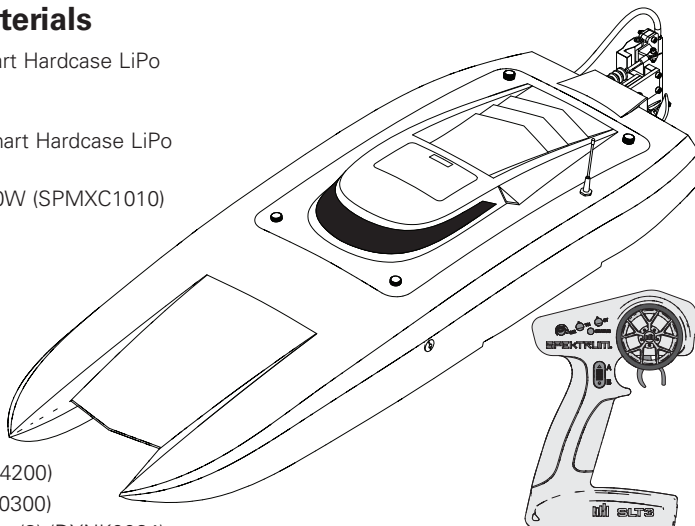

Product Inspection

Carefully remove the boat and radio transmitter from the box. Inspect the boat for damage. If your product is damaged, please contact the hobby shop where you purchased your boat, or contact Horizon Hobby Product Support. Refer to the Warranty and Service Contact Information section for more info.

Boat Stand Assembly

1. Attach the side stand pieces to the end pieces as shown.
2. Use medium CA or epoxy adhesive to secure the side stand to the ends.
3. Allow the adhesive to dry before placing your boat on the stand.

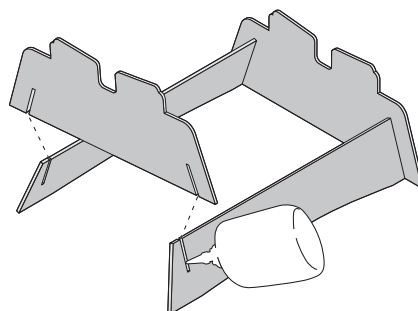

Antenna Tube Installation

1. Carefully feed the end of the receiver antenna through the grommet inside the hull.
2. Pull the antenna wire out of the grommet toward the outside of the boat, then slide the antenna through the antenna tube.
3. Insert the tube into the grommet, then fit the cap onto the tube.
4. Slide the clear 20mm silicone cooling line over the grommet and hull and install the tube into the silicone cooling line.

The antenna must be installed above the boat's waterline to get the best reception of your transmitter's signal.

NOTICE: Do not cut or kink the receiver antenna or damage may result.

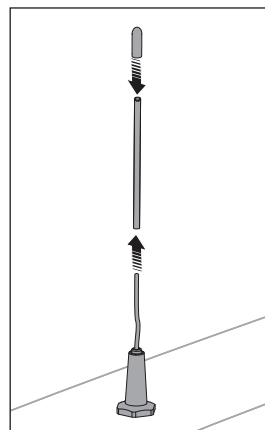

Canopy Removal

1. Loosen the 4 screws located at each corner of the canopy.
2. Remove the canopy from the hull starting with the 2 rear screws. Ensure that the 4 screws have disengaged from their bases before carefully lifting the canopy.

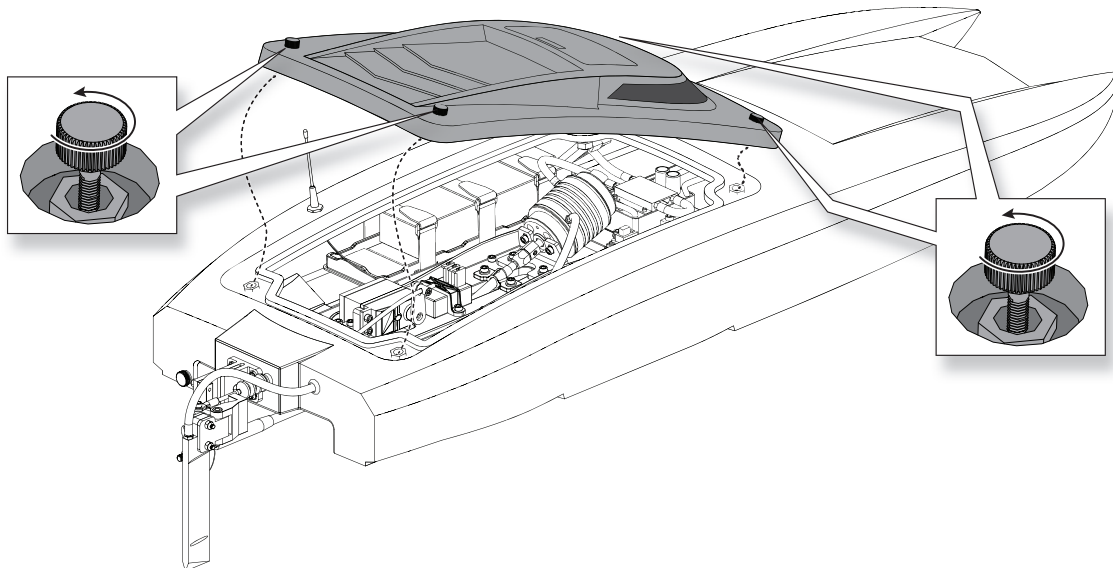

Installing the Battery Packs

The included electronics are rated for 2S–6S LiPo batteries; however, running the stock propeller nonstop on a 6S battery could overheat your electronics or damage your batteries. If you run the stock propeller on 6S, we recommend using full throttle on straight line passes only. Return passes should be at half throttle to reduce the heat of the electronics. If you want to run 6S nonstop, use optional propellers (PRB282006).

1. Install the 2 battery packs on the left and right sides of the boat hull. Secure the batteries with the included hook and loop straps. When running your boat in rough water, use Waterproof Hook and Loop Tape (DYNK0300) between the batteries and the battery tray to secure the batteries more fully.

Tip: Place the batteries as far back in the battery trays as possible to achieve maximum speed and handling. If water and wind conditions are too strong, stabilize the boat by moving the battery packs forward 1/4 inch at a time.

2. Connect each battery pack to the ESC power connectors.

The included propeller provides the best performance between 4S (14.8V) and 5S LiPo (18.5v). 5S configuration can be achieved by mounting a 3S LiPo (SPMX53S100H5) on the left side of the boat and a 2S, LiPo (SPMX52S100H5) on the right side of the boat. The added weight of the 3S battery on the left side will counteract torque twist caused by the propeller spinning at high RPM.

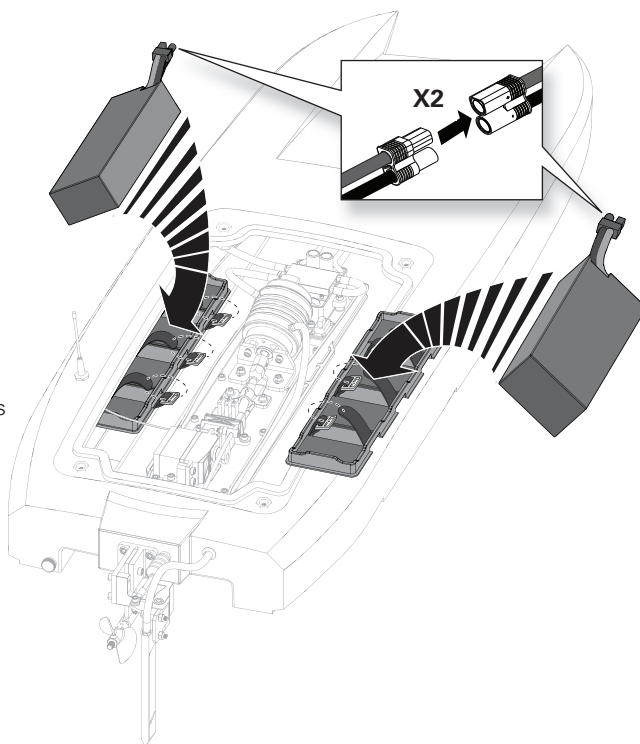

WARNING: When using 2 batteries in series, always make sure they are in roughly the same condition (age) and they have the same capacity (mAh) and discharge rate (C rating). Failure to do so may cause damage to your batteries, potentially causing a fire.

Transmitter Functions

Specifications

Power Supply: 4 AA Batteries

Operating Frequency: 2.4GHz

Transmit Power: <100mw

Control Protocol: SLT

Control: Proportional Steering and Throttle/Brake with Trim Knobs, Third Channel with 3 Position Momentary Switch

Auxiliary Functions: 3 Position Throttle Limit Switch, Steering Rate Knob to Change Steering Travel on-the-fly, Programmable Servo Travel for Steering and Throttle/Brake

A. Throttle Trim

Adjusts the throttle neutral point

B. Steering Trim

Adjusts the steering center point. Normally, the steering trim is adjusted until the vehicle tracks straight.

C. LED

- Solid red lights: Indicates the power is ON and adequate battery power
- Flashing red lights: Indicates the battery voltage is critically low. Replace batteries

D. Steering Wheel

E. Throttle/Brake

F. Steering Rate

On-The-Fly knob for travel adjustment on the steering

G. Channel 3

3 position momentary switch, middle position is neutral
For programming press up for A button, press down for B button

H. Throttle Limit

Limits throttle output to 50/75/100%

Select 50% or 75% for less experienced drivers or when you are driving the vehicle in a small area.

I. Throttle (TH) Servo Reversing

Move the switch to reverse the throttle channel

J. Steering (ST) Servo Reversing

Move the switch to reverse the steering channel

K. Power Button

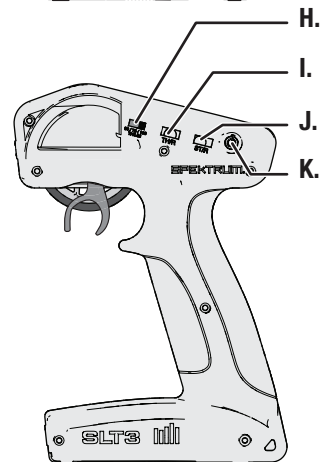
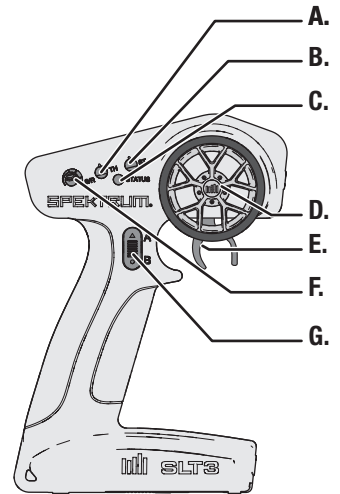

Installing the transmitter Batteries

This transmitter requires 4 AA batteries.

1. Remove the battery cover from the transmitter.
2. Install the batteries as shown.
3. Install the battery cover.

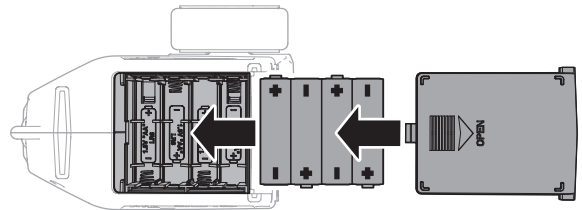

CAUTION: If using rechargeable batteries, charge only rechargeable batteries. Charging non-rechargeable batteries may cause the batteries to burst, resulting in injury to persons and/or damage to property.



CAUTION: Risk of explosion if battery is replaced by an incorrect type. Dispose of used batteries according to national regulations.

Factory Reset

There is a hidden mode if you want to reset the servo travel and calibration in the transmitter.

1. Hold full left and full brake while powering the transmitter ON to put the transmitter into programming mode. The LED will flash 4 times then turns OFF to indicate factory reset.
2. Release the wheel and throttle trigger back to neutral and the LED will illuminate to indicate factory reset is complete.
3. Power the transmitter OFF.

Battery Charger

Choose a charger designed to charge the recommended (2) Spektrum 7.4V 5000mAh 2S 100C Smart Hardcase LiPo Battery: IC5 (SPMX50002S100H5), or (2) Spektrum 11.1V 5000mAh 3S 100C Smart Hardcase LiPo Battery: IC5 (SPMX50003S100H5). We recommend the Spektrum Smart S2100 AC Charger, 2x100W (SPMXC1010).

Refer to your charger manual for charging instructions and safety information.

NOTICE: Never charge a battery in the boat or damage may result.

Low Voltage Cutoff (LVC)

Discharging a Li-Po battery below 3V per cell may damage your battery. The included ESC protects the boat battery from over-discharge using Low Voltage Cutoff (LVC). Before the battery charge decreases too much, LVC removes power supplied to the motor. Power to the motor pulses, showing that some battery power is reserved for boat control and safe landing.

Disconnect and remove the Li-Po battery from the boat after use to prevent trickle discharge. Charge your Li-Po battery to about half capacity before storage. During storage, make sure the battery charge does not fall below 3V per cell. LVC does not prevent the battery from over-discharge during storage.

NOTICE: Repeated operation to LVC will damage the battery.

Tip: Monitor your boat battery's voltage before and after boating by using a Spektrum XBC100 Smart Battery Checker & Servo Driver (SPMXBC100, sold separately).

Battery Chemistry

The ESC comes from the factory in Li-Po Mode. To change battery chemistry:

1. Keep the throttle at neutral and power ON the ESC.
2. Press and hold the Battery Chemistry Button on the power switch for 3 seconds. The LED flashes the current battery chemistry (red = Ni-MH or Ni-Cd; green = Li-Po).
3. Continue holding the Battery Chemistry Button for another 6 seconds. The ESC changes battery chemistry and the LED flashes the new battery chemistry.
4. Power OFF the ESC. The ESC saves the setting until it is changed.

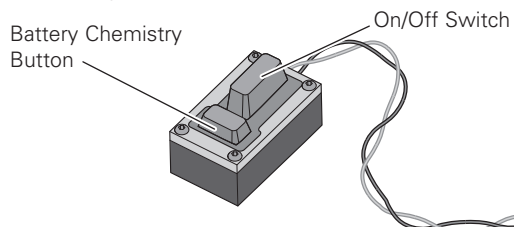

Getting Started

1. Power on the transmitter.
2. Connect the two batteries to the EC5™ connectors on the ESC.
3. Power on the ESC switch. The ESC arming tones will sound.
4. Test the transmitter's control of the boat with the boat on the display stand.

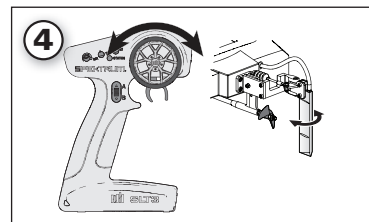
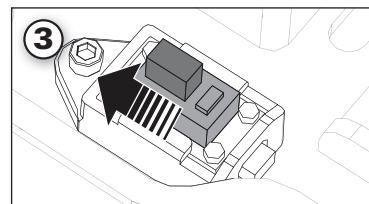
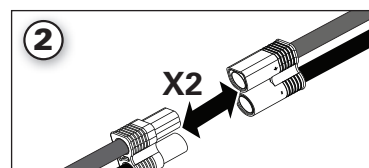
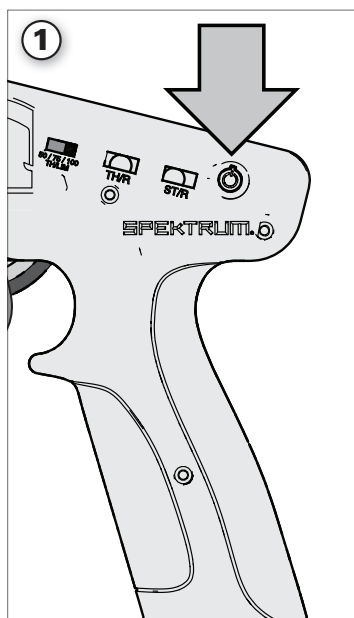

SPMSR315 Dual Protocol Receiver

Specifications

Type: Dual Protocol 3 Ch Receiver* (SLT/DSMR)

Dimensions (LxWxH): 32.5 x 21.5 x 12.4mm

Antenna Length: 90mm

Channels: 3

Weight: 6g

Band: 2.4GHz

Voltage Range: 3.5–9.6V

Bind Type: Bind Button

Failsafe: Hold the steering wheel and throttle trigger in the desired failsafe positions during binding

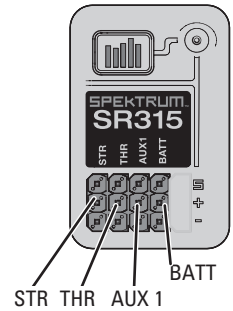

*SPMSR315 receivers included with the SLT3 transmitter include SLT and DSMR compatibility. If you have an SR315 receiver that was purchased by itself, you may need to install a firmware update to make your SR315 SLT compatible.

Receiver Antenna

The SR315 receivers feature a coaxial antenna design for easy installation in almost any model. Think of the last 1 inch (32mm) on the tip of the antenna as the active portion of the antenna, the coaxial portion leading up to it is just an extension. Install the antenna so the active portion is positioned as high as possible in the vehicle, and not "in the shadow" of any carbon fiber or metal. The case of the receiver can accept an antenna tube directly, making optimal antenna placement easy (antenna tube not included).



WARNING: Do not kink, cut or damage the antenna wire. The antenna is made of a coaxial wire; if the outer sheath becomes damaged, the receiver will not work properly. If the antenna is damaged in any way, replace the antenna before attempting to use the receiver.

Binding to SLT

Binding is the process of programming the receiver to recognize the GUID (Globally Unique Identifier) code of a single specific transmitter.

Binding Procedure

1. Power ON the receiver, press the bind button three times quickly (within 1.5 seconds of the first button press). The LED will begin to flash with a pause.
2. Set the trims and control positions at the desired failsafe settings, and power ON the SLT3 transmitter.
3. When the LED on the SLT3 transmitter and receiver remain lit, binding is complete.

You must rebind when:

- Different failsafe positions are desired e.g., when throttle or steering reversing has been changed.
- Binding the receiver to a different transmitter.

Binding to DSMR/DSM2

Binding Procedure

1. Push and Hold Bind Button
2. Power on Receiver
3. Release Button after RX goes into Bind Mode (flashing LED)
4. Place transmitter in Bind Mode and finish Binding.

Failsafe

In the unlikely event that the radio connection is lost during use, the receiver will drive the servos to their pre-programmed failsafe positions as set during Binding.

If the receiver is powered on before powering on the transmitter, the receiver will enter this failsafe mode. When the transmitter is powered on, normal control is resumed.

IMPORTANT: Failsafe activates only in the event that signal is lost from the transmitter. Failsafe will NOT activate in the event that receiver battery power decreases below the recommended minimums or power to the receiver is lost.

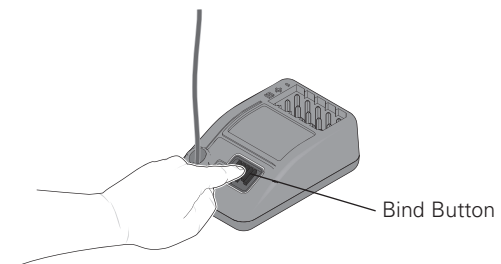

Servo Travel

The servo travel on the Steering and Throttle channels can be adjusted through a special programming mode in the transmitter.

1. Begin with the transmitter binding process to the receiver complete. Power ON the receiver.
2. Hold full right and full brake while powering the transmitter ON to put the transmitter into programming mode. The LED on the transmitter will flash 4 times to indicate it is in programming mode.
3. Turn and hold the wheel full left to set the travel limit for that direction, Press the A button to increase travel, press the B button to reduce travel. The LED will flash once with every change. Return the wheel to center to set the travel value.

IMPORTANT: If the value has reached the maximum or minimum that can be accepted, the LED will not flash with further input.

4. Turn the wheel to the right and repeat the process to set the steering travel to the right.
5. For electric vehicles, power the Transmitter OFF to save the settings. Calibrate your ESC to the default throttle travel.
6. For fuel powered vehicles, set the throttle travel without the engine running; After setting steering travel, you can set throttle travel with the same process. Pull and hold full throttle, adjust travel with the A and B buttons, return to center to set the value.
7. Push full brake, adjust travel with the A and B buttons, return to center
8. Power the transmitter OFF to save the values.

Control Check

IMPORTANT: Perform a control check at the beginning of each boating session, after repair or after installation of new batteries.

Ensure the receiver antenna is extended properly and all batteries are fully charged.

1. Power ON the transmitter and the boat. **Do not install the boat canopy.**
2. Place the boat securely on the boat stand.

NOTICE: Do not operate the engine without water cooling circulation or damage may result.

3. Check steering and throttle on the transmitter.

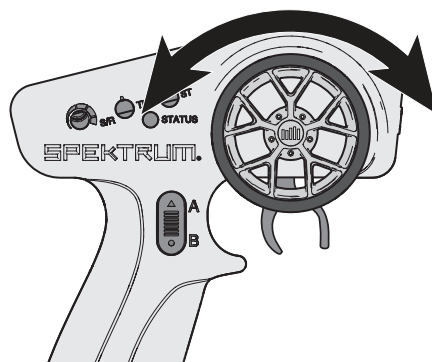

Testing Your Boat in the Water

Tip: Before placing your boat in the water, secure the canopy on the hull. Apply clear tape (DYNM0102) around the canopy seam, if desired.

1. Carefully place the boat in the water.
2. Operate the boat at slow speeds near the shoreline. Avoid objects in the water at all times. When the boat is moving forward, ensure water flows out of the coolant outlet. Remove any blockage from the rudder inlet and coolant system or the motor and ESC (electronic speed control) may overheat.
3. Once you are comfortable operating the boat at slow speeds, it is safe to operate the boat farther from the shore.
4. If the boat does not go straight, adjust the steering trim dial on the transmitter.

Tip: If you are using excessive steering trim on your transmitter to make the boat drive straight, return the trim to neutral and mechanically center the rudder. To do this, use a 1.5mm hex driver to loosen the set screw holding the push rod to the servo. Adjust the linkage in or out of the brass barrel until the rudder is centered. Tighten the set screw using a 1.5mm hex driver.

5. Bring the boat back to shore when you notice the boat starting to lose speed.
6. Power off the ESC and disconnect the battery packs.
7. Allow the motor, ESC and battery packs to cool before charging the batteries or operating the boat again.

NOTICE: Always power OFF the receiver before powering OFF the transmitter. If the transmitter is powered OFF before the receiver, the receiver will enter failsafe mode.

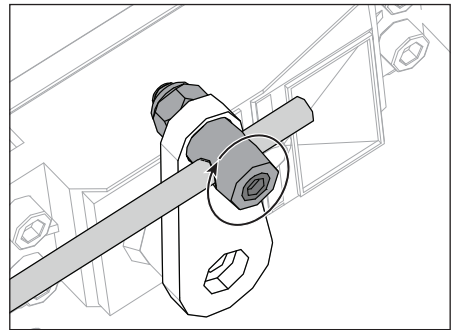
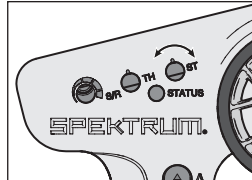

Boating Tips

When running your boat for the first time, we recommend calm wind and water conditions so that you can learn how the boat responds to your control.

Maximum speeds are only achieved when the water conditions are smooth and there is little wind. A sharp turn, wind or waves can turn over a boat when it is moving quickly. Always pilot your boat for the wind and water conditions so that the boat does not turn over.

Tip: Use Clear Flexible Marine Tape (DYNM0102) around the canopy when running your boat in rough water.

Consult local laws and ordinances before choosing a location to pilot your boat.

Avoid boating near:

- watercraft
- people (swimming areas, fishing areas)
- stationary objects
- waves, wakes
- rapidly moving water
- wildlife
- floating debris
- overhanging trees
- vegetation

If the propeller and rudder are blocked with debris or vegetation, remove the boat from the water and remove the debris before continuing operation.

When making turns, decrease the throttle to reduce the probability of flipping the boat over. If necessary, adjust your steering input to decrease sensitivity.

Never operate your boat in less than 12 inches (30.5 cm) of water.

If you need to retrieve your boat from the water, use fishing equipment or another boat.

NOTICE: When running at full speed in choppy waters, the prop may exit and re-enter the water repeatedly and very quickly, subjecting the propeller and flex shaft to some stress. Frequent stress may damage the propeller and flex shaft.



CAUTION: Never operate your boat in extreme temperatures or turbulent water.



CAUTION: Never attempt to retrieve a downed boat by swimming.

When You Are Finished

1. Power off the receiver.
2. Power off the transmitter.
3. Disconnect and remove the batteries from the boat.

Tip: Always remove the canopy before storage or moisture may allow mold and mildew to grow in the boat.

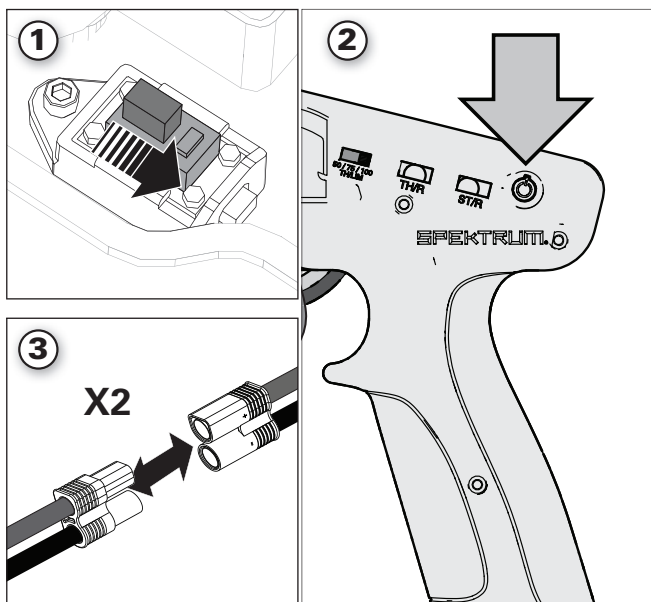

After Boating and Maintenance

- Drain water from inside the hull using the drain plug
- Fully dry the inside and outside of the boat, including the water cooling lines and jacket around the motor. Remove the hatch before storing your boat
- Repair any damage or wear to the boat
- Lubricate the flex shaft using Pro Boat Marine Grease (DYNE4200)
- Make note of lessons learned from the trimming of your boat, including water and wind conditions

Tip: The hook and loop strips in the boat retain water. To dry them, press on them with a dry cloth.

NOTICE: When you are finished boating, never leave the boat in direct sunlight or in a hot, enclosed area such as a car. Doing so can damage the boat.

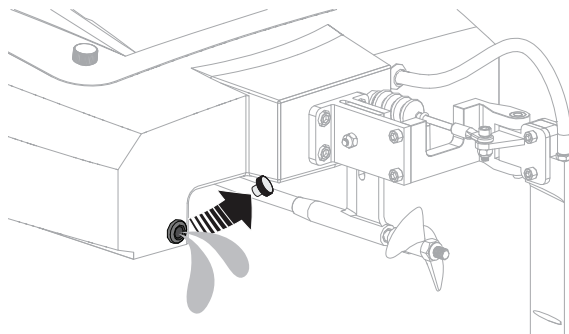

Motor Care

- Prolong motor life by preventing overheating conditions. Undue motor wear results from frequent turns, stops and starts, pushing objects, boating in rough water or vegetation and boating continuously at high speed.
- Over-temperature protection is installed on the ESC to prevent circuit damage, but cannot protect the motor from excessive physical resistance.
- Use Dynamite Precision Oiler (DYNE0100) to service the motor's bearings. If the bearings get wet, use water displacement fluid then oil the bearings to prevent rust or seizure.

Water Cooling System

If water does not stream out of the water outlets while the boat is moving forward, immediately return the boat to shore and clean any obstructions or remove kinks from the water cooling lines/system.

1. Disassemble and clean the water cooling system to remove blockage and prevent overheating.
2. Replace damaged parts.

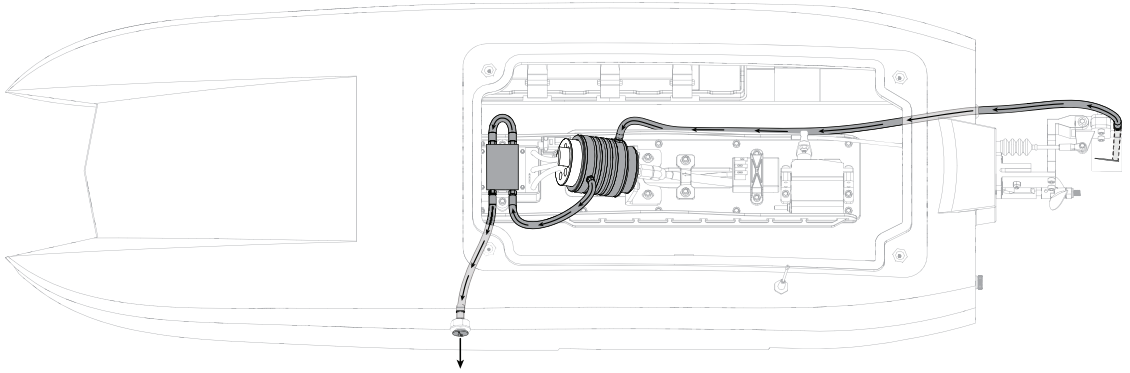

Rudder Service

1. Disconnect the water tube from the rudder.
2. Remove the nut, screw and linkage from the rudder arm.
3. Turn the rudder and loosen the set screw from the rudder pin.
4. Turn over the boat and lightly tap the rudder to remove the pin.
5. Assemble in reverse order.

Tip: Use a Nylon Breakaway Screw (PRB285000) as a replacement for the rudder breakaway bolt.

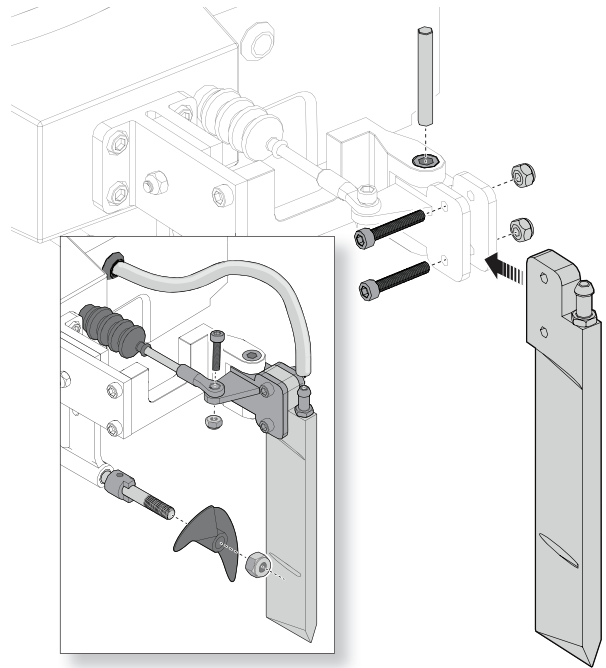

Propeller Service

1. Use an 8mm nut driver (DYN2805) to loosen the nut from the driveshaft. To secure the propeller while loosening the nut, hold the propeller.
2. Remove the nut and propeller from the driveshaft.
3. Assemble in reverse order. Correctly align the propeller with the drive dog on the driveshaft.

Propeller Strut Depth Adjustment

Raising the propeller strut increases speed but decreases handling.

Lowering the propeller strut increases stability but decreases speed.

1. Use a 3 mm hex driver and 7mm open-end wrench to loosen the propeller strut bolt.
2. Slide the strut up or down to change the angle of the propeller in relation to the hull.
3. Once desired strut depth is achieved, tighten the nuts and bolts.

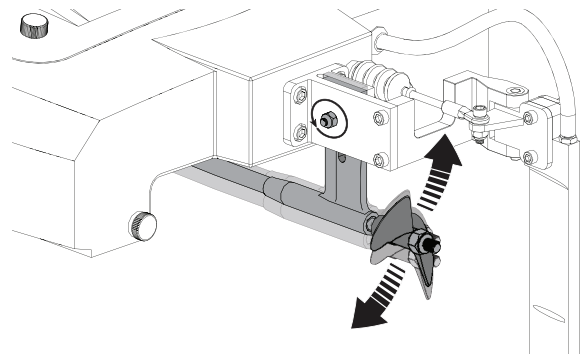

Drivetrain Lubrication

Always replace the drivetrain parts when they are damaged or show visible wear or injury and damage may result.

Lubricating the flex shaft is vital to the life of the drivetrain. The lubricant also acts as a water seal, keeping water from entering the hull through the stuffing tube.

Lubricate the flex shaft and propeller strut after every 30 minutes of operation and/or everytime you change the batteries.

1. Inside the hull, use 2 10mm open-end wrenches to loosen the collet nut from the flex shaft.
2. Slide the flex shaft out from the stuffing tube and drive strut at the rear of the boat.
3. Wipe the old lubricant and material from the flex shaft.

Tip: Use motor spray (DYN5500) to break down the grease buildup.

4. Lubricate the full length of the flex shaft assembly up to the drive dog using Dynamite Marine Grease (DYNE4200). Also apply grease to the collet threads.
5. Carefully reinstall the flex shaft in the drive strut, stuffing tube and collet. If the flex shaft is difficult to remove from (or install into) the collet, rotate the flex shaft to the right while pulling it from (or inserting it into) the collet.

NOTICE: Do not rotate the flex shaft to the left inside the coupler.

Ensure there is a 2mm gap between the drive strut and drive dog to allow for flex shaft shrinkage under load.

NOTICE: Running the boat in saltwater could cause some parts to corrode. If you run the boat in saltwater, rinse it thoroughly in freshwater after each use and lubricate the drive system.

NOTICE: Because of its corrosive effects, running RC boats in saltwater is at the discretion of the modeler.

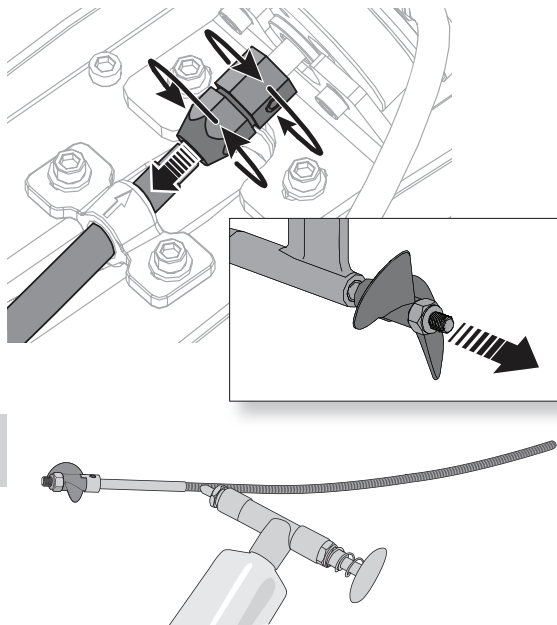

Transmitter Programming

1. Pull and hold the Throttle Trigger to full throttle and turn the ESC on.
2. After 2 seconds a “-B-B” will sound. Wait another 5 seconds and the ESC will give a rising tone to indicate you have entered **Programming Mode**.
3. After entering Programming Mode, you will hear 4 tones in a loop indicating **Programmable Items**. Push the Throttle Trigger to full brake within 3 seconds after the tone sounds matching the programmable item you want to select.
4. After selecting a programmable item, you will hear several tones in a loop indicating **Programmable Values**. Pull Throttle Trigger to full throttle to select the value matching the tone. The ESC will give an alternating tone to indicate the item is selected.
5. Keep the trigger in Full Throttle to return to **Step 3** and continue item selection. Move the throttle stick to full brake position within 2 seconds to exit the Program Mode.

The black-shaded setting is the factory default

Programmable Items	Programmable Value				-B Single Beep		B— Long Beep	
	-B	-B-B	-B-B-B	-B-B-B-B	B—	B— -B	B— -B-B	B— -B-B-B
Running Mode -B	Forward Only	Forward/ Backward						
Li-Po Cells -B-B	Auto Calc.	2s	3s	4s	5s	6s		
Low Voltage Cutoff -B-B-B	None	2.8V/Cell	3.0V/ Cell	3.2V/Cell	3.4V/ Cell			
Timing -B-B-B-B	0.00°	3.75°	7.50°	11.25°	15.00°	18.75°	22.50°	26.25°



Troubleshooting Guide

Problem	Possible Cause	Solution
Boat will not respond to throttle but responds to other controls	Throttle channel is reversed	Reverse throttle channel on transmitter
Extra noise or extra vibration	Damaged propeller, shaft or motor	Replace damaged parts
	Propeller is out of balance	Balance or replace propeller
Reduced runtime or boat underpowered	Boat battery charge is low	Completely recharge battery
	Boat battery is damaged	Replace boat battery and follow battery instructions
	Blocking or friction on shaft or propeller	Disassemble, lubricate and correctly align parts
	Boat conditions may be too cold	Make sure the battery is warm (above 10° C [50° F]) before use
	Battery capacity may be too low for conditions	Replace battery or use a larger capacity battery
	Too little lubrication on driveshaft	Fully lubricate driveshaft
	Vegetation or other obstacles block the propeller	Remove vegetation or obstacles from propeller
Boat will not Bind (during binding) to transmitter	Transmitter is too near boat during binding process	Move powered transmitter a few feet from boat, disconnect and reconnect battery to boat
	Boat or transmitter is too close to large metal object, wireless source or another transmitter	Move the boat and transmitter to another location and attempt binding again
	Another compatible transmitter in bind mode within range of the receiver	Power off all compatible transmitters except the one you are trying to bind
	Boat battery/transmitter battery charge is too low	Replace/recharge batteries
	ESC switch is off	Power on ESC switch
Boat will not connect (after binding) to transmitter	Transmitter is too near boat during connecting process	Move powered transmitter a few feet from boat, disconnect and reconnect battery to boat
	Boat or transmitter is too close to large metal object, wireless source or another transmitter	Move boat or transmitter to another location and attempt to connect again
	Boat battery/transmitter battery charge is too low	Replace/recharge batteries
	ESC switch is off	Power on ESC switch
Boat tends to dive in the water or takes on water	The boat hull is not completely closed	Dry out the boat and ensure the hatch is fully closed on the hull before returning the boat to the water
	Center of gravity is too far forward	Move batteries back in the hull
Controls reversed	Transmitter settings are reversed	Do the Control Direction Test and adjust controls on transmitter appropriately
Motor overheats	Blocked water cooler lines	Clean, unkink or replace water lines
Motor power pulses then motor loses power	Weather conditions might be too cold	Postpone until weather is warmer
	Battery is old, worn out or damaged	Replace battery
Boat moves forward or backward without input from user	Throttle trim on transmitter not centered	Adjust throttle trim to center (12 o'clock)
Boat does not drive straight	Steering trim on transmitter not centered	Adjust steering trim so vehicle drives straight
No steering or lack of steering	Steering rate not adjusted correctly	Adjusts steering rate (ST RATE) knob on transmitter to desired steering throw
	Servo failed	Contact Horizon Product Support
No throttle or lack of throttle	ESC failed	Contact Horizon Product Support
	Motor failed	Contact Horizon Product Support
ESC emits a continues tone when powered on	Throttle trim not centered	Center throttle trim on transmitter

Limited Warranty

What this Warranty Covers

Horizon Hobby, LLC, (Horizon) warrants to the original purchaser that the product purchased (the "Product") will be free from defects in materials and workmanship at the date of purchase.

What is Not Covered

This warranty is not transferable and does not cover (i) cosmetic damage, (ii) damage due to acts of God, accident, misuse, abuse, negligence, commercial use, or due to improper use, installation, operation or maintenance, (iii) modification of or to any part of the Product, (iv) attempted service by anyone other than a Horizon Hobby authorized service center, (v) Product not purchased from an authorized Horizon dealer, or (vi) Product not compliant with applicable technical regulations or (vii) use that violates any applicable laws, rules, or regulations.

OTHER THAN THE EXPRESS WARRANTY ABOVE, HORIZON MAKES NO OTHER WARRANTY OR REPRESENTATION, AND HEREBY DISCLAIMS ANY AND ALL IMPLIED WARRANTIES, INCLUDING, WITHOUT LIMITATION, THE IMPLIED WARRANTIES OF NON-INFRINGEMENT, MERCHANTABILITY AND FITNESS FOR A PARTICULAR PURPOSE. THE PURCHASER ACKNOWLEDGES THAT THEY ALONE HAVE DETERMINED THAT THE PRODUCT WILL SUITABLY MEET THE REQUIREMENTS OF THE PURCHASER'S INTENDED USE.

Purchaser's Remedy

Horizon's sole obligation and purchaser's sole and exclusive remedy shall be that Horizon will, at its option, either (i) service, or (ii) replace, any Product determined by Horizon to be defective. Horizon reserves the right to inspect any and all Product(s) involved in a warranty claim. Service or replacement decisions are at the sole discretion of Horizon. Proof of purchase is required for all warranty claims. SERVICE OR REPLACEMENT AS PROVIDED UNDER THIS WARRANTY IS THE PURCHASER'S SOLE AND EXCLUSIVE REMEDY.

Limitation of Liability

HORIZON SHALL NOT BE LIABLE FOR SPECIAL, INDIRECT, INCIDENTAL OR CONSEQUENTIAL DAMAGES, LOSS OF PROFITS OR PRODUCTION OR COMMERCIAL LOSS IN ANY WAY, REGARDLESS OF WHETHER SUCH CLAIM IS BASED IN CONTRACT, WARRANTY, TORT, NEGLIGENCE, STRICT LIABILITY OR ANY OTHER THEORY OF LIABILITY, EVEN IF HORIZON HAS BEEN ADVISED OF THE POSSIBILITY OF SUCH DAMAGES. Further, in no event shall the liability of Horizon exceed the individual price of the Product on which liability is asserted. As Horizon has no control over use, setup, final assembly, modification or misuse, no liability shall be assumed nor accepted for any resulting damage or injury. By the act of use, setup or assembly, the user accepts all resulting liability. If you as the purchaser or user are not prepared to accept the liability associated with the use of the Product, purchaser is advised to return the Product immediately in new and unused condition to the place of purchase.

Law

These terms are governed by Illinois law (without regard to conflict of law principals). This warranty gives you specific legal rights, and you may also have other rights which vary from state to state. Horizon reserves the right to change or modify this warranty at any time without notice.

WARRANTY SERVICES

Questions, Assistance, and Services

Your local hobby store and/or place of purchase cannot provide warranty support or service. Once assembly, setup or use of the Product has been started, you must contact your local

distributor or Horizon directly. This will enable Horizon to better answer your questions and service you in the event that you may need any assistance. For questions or assistance, please visit our website at www.horizonhobby.com, submit a Product Support Inquiry, or call the toll free telephone number referenced in the Warranty and Service Contact Information section to speak with a Product Support representative.

Inspection or Services

If this Product needs to be inspected or serviced and is compliant in the country you live and use the Product in, please use the Horizon Online Service Request submission process found on our website or call Horizon to obtain a Return Merchandise Authorization (RMA) number. Pack the Product securely using a shipping carton. Please note that original boxes may be included, but are not designed to withstand the rigors of shipping without additional protection. Ship via a carrier that provides tracking and insurance for lost or damaged parcels, as Horizon is not responsible for merchandise until it arrives and is accepted at our facility. An Online Service Request is available at http://www.horizonhobby.com/content/service-center_render-service-center. If you do not have internet access, please contact Horizon Product Support to obtain a RMA number along with instructions for submitting your product for service. When calling Horizon, you will be asked to provide your complete name, street address, email address and phone number where you can be reached during business hours. When sending product into Horizon, please include your RMA number, a list of the included items, and a brief summary of the problem. A copy of your original sales receipt must be included for warranty consideration. Be sure your name, address, and RMA number are clearly written on the outside of the shipping carton.

NOTICE: Do not ship Li-Po batteries to Horizon. If you have any issue with a Li-Po battery, please contact the appropriate Horizon Product Support office.

Warranty Requirements

For Warranty consideration, you must include your original sales receipt verifying the proof-of-purchase date. Provided warranty conditions have been met, your Product will be serviced or replaced free of charge. Service or replacement decisions are at the sole discretion of Horizon.

Non-Warranty Service

Should your service not be covered by warranty, service will be completed and payment will be required without notification or estimate of the expense unless the expense exceeds 50% of the retail purchase cost. By submitting the item for service you are agreeing to payment of the service without notification. Service estimates are available upon request. You must include this request with your item submitted for service. Non-warranty service estimates will be billed a minimum of ½ hour of labor. In addition you will be billed for return freight. Horizon accepts money orders and cashier's checks, as well as Visa, MasterCard, American Express, and Discover cards. By submitting any item to Horizon for service, you are agreeing to Horizon's Terms and Conditions found on our website http://www.horizonhobby.com/content/service-center_render-service-center.

ATTENTION: Horizon service is limited to Product compliant in the country of use and ownership. If received, a non-compliant Product will not be serviced. Further, the sender will be responsible for arranging return shipment of the un-serviced Product, through a carrier of the sender's choice and at the sender's expense. Horizon will hold non-compliant Product for a period of 60 days from notification, after which it will be discarded.



Warranty and Service Contact Information

Country of Purchase	Horizon Hobby	Phone Number/Email Address	Address
North America	Horizon Service Center (Repairs and Repair Requests)	servicecenter.horizonhobby.com/ RequestForm/	2904 Research Rd Champaign, Illinois, 61822 USA
	Horizon Product Support (Product Technical Assistance)	productsupport@horizonhobby.com 877-504-0233	
	Sales	websales@horizonhobby.com 800-338-4639	
European Union	Horizon Technischer Service	service@horizonhobby.eu	Hanskampring 9 D 22885 Barsbüttel, Germany
	Sales: Horizon Hobby GmbH	+49 (0) 4121 2655 100	

FCC Information:

FCC ID: BRWSPMLT300

FCC ID: BRWSRIRVINGV1

FCC This device complies with part 15 of the FCC Rules. Operation is subject to the following two conditions: (1) This device may not cause harmful interference, and (2) this device must accept any interference received, including interference that may cause undesired operation.



CAUTION: Changes or modifications not expressly approved by the party responsible for compliance could void the user's authority to operate the equipment.

NOTE: This equipment has been tested and found to comply with the limits for a Class B digital device, pursuant to part 15 of the FCC Rules. These limits are designed to provide reasonable protection against harmful interference in a residential installation. This equipment generates, uses and can radiate radio frequency energy and, if not installed and used in accordance with the instructions, may cause harmful interference to radio communications. However, there is no guarantee that interference will not occur in a particular installation. If this equipment does cause harmful interference to radio or television reception, which can be determined by turning the equipment off and on, the user is encouraged to try to correct the interference by one or more of the following measures:

- Reorient or relocate the receiving antenna.
- Increase the separation between the equipment and receiver.
- Connect the equipment into an outlet on a circuit different from that to which the receiver is connected.
- Consult the dealer or an experienced radio/TV technician for help.

Horizon Hobby, LLC
2904 Research Rd.,
Champaign, IL 61822
Email: compliance@horizonhobby.com
Web: HorizonHobby.com

IC Information

IC: 6157A-SPMLT300

IC: 6157A-SRIRVINGV1

CAN ICES-3 (B)/NMB-3(B)

This device contains license-exempt transmitter(s)/receiver(s) that comply with Innovation, Science, and Economic Development Canada's license-exempt RSS(s). Operation is subject to the following 2 conditions:

1. This device may not cause interference.
2. This device must accept any interference, including interference that may cause undesired operation of the device.



EU Compliance Statement: Hereby, Horizon Hobby, LLC declares that the device is in compliance with the following:

EU Radio Equipment Directive 2014/53/EU;

RoHS 2 Directive 2011/65/EU

RoHS 3 Directive - Amending 2011/65/EU Annex II 2015/863

The full text of the EU declaration of conformity is available at the following internet address: <https://www.horizonhobby.com/content/support-render-compliance>.

Wireless Frequency Range and Wireless Output Power SLT3 Transmitter

Max EIRP:16.3

Frequency Range:2403-2480MHz

SR315 Receiver

Max EIRP: -1.33dBm

Frequency Range: 2404-2476MHz

EU Manufacturer of Record:

Horizon Hobby, LLC
2904 Research Road
Champaign, IL 61822 USA

EU Importer of Record:

Horizon Hobby, GmbH
Hanskampring 9
22885 Barsbüttel Germany



WEEE NOTICE:

This appliance is labeled in accordance with European Directive 2012/19/EU concerning waste of electrical and electronic equipment (WEEE). This label indicates that this product should not be disposed of with household waste. It should be deposited at an appropriate facility to enable recovery and recycling.



Antenna Separation Distance

When operating your Spektrum transmitter, please be sure to maintain a separation distance of at least 5 cm between your body (excluding fingers, hands, wrists, ankles and feet) and the antenna to meet RF exposure safety requirements as determined by FCC regulations.

The following illustrations show the approximate 5 cm RF exposure area and typical hand placement when operating your Spektrum transmitter.

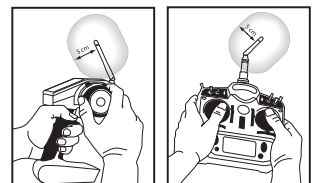

Replacement Parts / Ersatzteile / Pièces de rechange / Pezzi di ricambio

Part #	English	Deutsch	Français	Italiano
DYNAM3831	3650 6 Pole Marine Motor 2000Kv	3650 6-poliger Bootsmotor 2000 kv	Moteur 3650 6 Pôles Marine 2000Kv	Motore marino 6 poli 3650 2000 Kv
DYNAM3875	120A BL Marine ESC 2-6S	120 A bürstenloser Geschwindigkeitsregler 2-6S	120A BL Marine ESC 2-6S	ESC marino brushless 120 A 2-6S
PRB281058	Hull: Veles 29-inch	Rumpf: Veles 29-inch	Coque : Veles 29-inch	Scafo: Veles 29"
PRB281059	Canopy: Veles 29-inch	Verdeck: Veles 29-inch	Canopée : Veles 29-inch	Capottina: Veles 29"
PRB281060	Rudder: Veles 29-inch	Ruder: Veles 29-inch	Gouvernail : Veles 29-inch	Timone: Veles 29"
PRB282047	Propeller: UL 19 30-inch Hydroplane 1.7 x 1.6	Propeller: UL 19 76-cm-Wasserflugzeug 1,7 x 1,6	Hydroplane UL 19 30-inch RTR - Hélice 1,7 x 1,6	Elica: idroplano UL 19 30" 1,7 x 1,6
PRB282049	Motor Mount: Veles 29	Motorhalterung: Veles 29	Support moteur : Veles 29	Supporto motore: Veles 29"
PRB285000	ProBoat Break-away screw, nylon	ProBoat Abbrechschraube, Nylon	Écrou de sécurité en nylon Pro Boat	Vite sganciabile ProBoat, nylon
PRB286098	Prop Strut: Veles 29	Propellerstrebe: Veles 29	Veles 29 - Chaise d'hélice	Supporto esterno asse dell'elica: Veles 29
SPMSLT300	SLT3 3-Channel SLT Radio System with SR315 Dual Protocol Receiver	SLT3 3-Kanal-SLT-Funksystem mit SR315 Dual-Protokoll-Empfänger	Système radio SLT à 3 canaux SLT3 avec récepteur double protocole SR315	Radiocomando SLT3 a 3 canali con ricevitore SR315 a doppio protocollo
SPMSR315	DSMR 3-Channel Sport Receiver	DSMR-Sportempfänger mit 3 Kanälen	Récepteur sport DSMR à 3 canaux	Ricevitore DSMR sport a 3 canali

Recommended Parts / Empfohlene Teile / Pièces recommandées / Pezzi consigliati

Part #	English	Deutsch	Français	Italiano
DYN2805	Nut Driver: 8mm	Mutterndreher: 8mm	Tournevis p/écrou: 8mm	Cacciavite a bussola: 8 mm
DYN2819	5 pc Metric Hex Driver Assortment	5-teiliges metrisches Inbusschlüssel-Set	Assortiment de 5 tournevis hexagonaux métriques (5pcs)	Set 5 pz. chiavi a brugola metriche
SPMXBC100	XBC100 Smart LiPo Battery Checker & Servo Driver	XBC100 Smart-LiPo-Akkuprüfer und Servotreiber	Contrôleur pour batterie Li-Po Smart XBC100 et servomoteur	Tester per batterie LiPo Smart e servomotore XBC100
DYN4201	Marine Grease 5 oz	Marine Grease 142 g (5 oz)	graisse marine 140g	grasso marino 5 oz
SPMX50002S100H5	7.4V 5000mAh 2S 100C Smart Hardcase LiPo Battery: IC5	7.4V 5000mAh 2S 100C Smart Li-Po-Akku, Hartschale: IC5	Batterie Li-Po Smart 7,4 V 5 000 mAh 2S 100C, boîtier rigide : IC5	Batteria 7,4V 5000 mAh 2S 100C Smart Hardcase LiPo: IC5
SPMX50003S100H5	11.1V 5000mAh 3S 100C Smart Hardcase LiPo Battery: IC5	11.1V 5000mAh 3S 100C Smart Li-Po-Akku, Hartschale: IC5	Batterie Li-Po Smart 7,4 V 5 000 mAh 2S 100C, boîtier rigide : IC5	Batteria 11,1 V 5000 mAh 3S 100C Smart Hardcase LiPo: IC5
SPMXCA508	Adapter: IC5 Battery / IC3 Device			
SPMXC1010	Smart S2100 AC Charger, 2x100W	Spektrum S2100 Smart Wechsel-/ Gleichstrom-Ladegerät, 2 x 100 W	Chargeur Spektrum Smart S2100 CA/CC, 2x100 W	Caricabatterie Spektrum S2100 CA/CC Smart, 2x100 W
DYNK0300	Hook and Loop Tape Set, Waterproof 75x25mm 4pcs	Klettbandsatz, Wasserfest 75 x 25 mm, 4 Stück	Adhésif auto-agrippant 75x25mm (4pcs)	Nastro a strappo, waterproof, 75 x 25 mm 4 pz.
DYNAM0102	Clear Flexible Marine Tape (18M)	Transparentes, flexibles Marine Tape (18 m)	Adhésif Marin transparent flexible (18M)	Nastro marino flessibile trasparente (18 m.)
DYNS3005	Dynamite LED Program Card	Dynamite LED-Programmkarte	Carte de programmation à DELs pour bateau	Scheda di programmazione LED Dynamite



Optional Parts / Diverse Teile / Pièces optionnelles / Pezzi opzionali

Part #	English	Deutsch	Français	Italiano
DYN2801	Nut Driver: 4mm	Mutterndreher: 4mm	Tournevis p/écrou: 4mm	Cacciavite a bussola: 4 mm
DYN2803	Nut Driver: 5.5mm	Mutterndreher: 5,5mm	Tournevis p/écrou: 5,5mm	Cacciavite a bussola: 5,5 mm
DYN4401	GPS Speed Meter	GPS-Tachometer	Tachymètre GPS	Tachimetro GPS
DYNB3855EC	Reaction HD 7.6V 5000mAh 2S 50C LiPo Hardcase: EC5	Reaction HD 7,6 V 5000 mAh 2S 50C Li-Po, Etui: EC5	Batterie Li-Po Reaction HD 2S 7,6V 5000mA 50C, boîtier rigide avec prise EC5	Batteria LiPo hardcase Reaction HD 50C 2S 7,6 V 5000 mAh: EC5
DYNB3856EC	Reaction HD 11.4V 5000mAh 3S 50C LiPo, Hardcase: EC5	Reaction HD 11,4 V 5000 mAh 3S 50C Li-Po, Etui: EC5	Batterie Li-Po Reaction HD 3S 11,4V 5000mA 50C, boîtier rigide avec prise EC5	Batteria LiPo hardcase Reaction HD 50C 3S 11,4 V 5000 mAh: EC5
DYNC0028	EC5 Battery Series Harness, 10ga	Kabelbaum für EC5 Akkureihe, 10ga	Cordon EC5 pour branchement en série, 10ga	Cavi batteria EC5, 10ga
DYNE4200	Grease Gun with Marine Grease 5 oz	Fettpresse mit Marine Grease 142 g (5 oz)	Pistolet avec graisse marine 140g	Pistola sparagrasso con grasso marino 5 oz
DYNT0502	Start Up Tool Set: Pro Boat	Anfänger-Werkzeugsatz: Pro Boat	Proboat - Set d'outils de démarrage	Set attrezzi: Pro Boat
PRB282006	Stainless Steel Propeller: Pro Boat 1.6 x 1.6 for 3/16 shaft	Propeller aus Edelstahl: Pro Boat 1,6 x 1,6 für 3/16 Welle	Hélice en acier inoxydable : Pro Boat 40,6 mm x 40,6 mm pour arbre 4,5 mm	Elica di acciaio inox: Pro Boat 1,6 x 1,6 per albero 3/16
PRB282027	Left Propeller: Zelos 36-inch Catamaran 1.4 x 1.65	Linker Propeller Zelos 91-cm Katamaran 1,4 x 1,65	Zelos 36 Twin Catamaran BL - Hélice gauche 1,4 x 1,65	Elica sinistra: catamarano Zelos 36" 1,4 x 1,65
SPM5000	DX5R 5CH DSMR Tx w/SR6000T	DX5R 5-Kanal DSMR Tx mit SR6000T	DX5R 5CH DSMR Tx avec SR6000T	Trasmittente DX5R DSMR 5 canali con SR6000T
SPMS605	9KG Servo, WP, Metal, 23T	9KG Servo, WP, Metallf, 23T	Servo 9Kg à pignons métalliques, étanche, tête 23T	Servo 9 kg., waterproof, metallo, 23T
SPMMR4000	MR4000 DSMR 4 Ch Marine Receiver	MR4000 DSMR 4 Ch Bootempfänger	Récepteur MR4000 4 voies marin	Ricevente marina MR4000 DSMR 4 canali
SPMSS6250	S6250 High Torque, HV Dig Servo	S6250 Digitaler HV-Servo mit hoher Drehzahl	Servo S6250 Digital HV, couple élevé	Servo digitale HV S6250 high torque

65812.2 PRB08029V2

Updated: 11/2022

©2022 Horizon Hobby LLC.

Pro Boat, the Pro Boat logo, Veles, DSMR, EC5, Dynamite, Reaction, Passport and the Horizon Hobby logo are trademarks or registered trademarks of Horizon Hobby, LLC. The Spektrum trademark is used with permission of Bachmann Industries, Inc. All other trademarks, service marks and logos are property of their respective owners.

US 9,930,567. US 10,419,970. US 10,849,013. Other patents pending.